

APPLYING AN OMICS APPROACH TO INVESTIGATE THE EFFECTS OF CITRUS AND CUCUMBER SUPPLEMENTATION ON BROILER CHICKENS UNDER CONTROL AND ESCHERICHIA COLI LPS CHALLENGE CONDITIONS

Riva, Francesca

Doctoral thesis / Disertacija

2022

Degree Grantor / Ustanova koja je dodijelila akademski / stručni stupanj: **University of Zagreb, Faculty of Veterinary Medicine / Sveučilište u Zagrebu, Veterinarski fakultet**

Permanent link / Trajna poveznica: <https://um.nsk.hr/um:nbn:hr:178:970330>

Rights / Prava: [In copyright](#) / [Zaštićeno autorskim pravom.](#)

Download date / Datum preuzimanja: **2024-07-10**



Repository / Repozitorij:

[Repository of Faculty of Veterinary Medicine -
Repository of PHD, master's thesis](#)





University of Zagreb



University
of Glasgow

UNIVERSITY
OF ZAGREB

FACULTY OF
VETERINARY MEDICINE

UNIVERSITY
OF GLASGOW

INSTITUTE OF
BIODIVERSITY,
ANIMAL HEALTH &
COMPARATIVE
MEDICINE

FRANCESCA RIVA

**APPLYING AN OMICS APPROACH TO
INVESTIGATE THE EFFECTS OF
CITRUS AND CUCUMBER
SUPPLEMENTATION ON BROILER
CHICKENS UNDER CONTROL
AND *ESCHERICHIA COLI* LPS
CHALLENGE CONDITIONS**

INTERNATIONAL DUAL DOCTORATE

Zagreb, 2022



University of Zagreb



University
of Glasgow

**UNIVERSITY
OF ZAGREB**

**FACULTY OF
VETERINARY MEDICINE**

**UNIVERSITY
OF GLASGOW**

**INSTITUTE OF
BIODIVERSITY,
ANIMAL HEALTH &
COMPARATIVE
MEDICINE**

FRANCESCA RIVA

**APPLYING AN OMICS APPROACH TO
INVESTIGATE THE EFFECTS OF
CITRUS AND CUCUMBER
SUPPLEMENTATION ON BROILER
CHICKENS UNDER CONTROL
AND *ESCHERICHIA COLI* LPS
CHALLENGE CONDITIONS**

INTERNATIONAL DUAL DOCTORATE

Supervisors:

Professor Maureen Bain, Professor Vladimir Mrljak,
Dr. Geert Bruggeman

Zagreb, 2022



University of Zagreb



University
of Glasgow

**SVEUČILIŠTA U
ZAGREBU**

**VETERINARSKI
FAKULTET**

**SVEUČILIŠTA U
GLASGOW**

**ZAVOD ZA
BIOLOŠKA
RAZNOLIKOST
ZDRAVLJE ŽIVOTINJA &
USPOREDNI LIJEK**

FRANCESCA RIVA

**PRIMJENA OMIC PRISTUPA U
ISTRAŽIVANJU UČINKA DODATKA
LIMUNA I KRASTAVCA NA TOVNE
PILIĆE U KONTROLNIM UVJETIMA I
UVJETIMA NAKON PRIMJENE
LIPOPOLISAHARIDA PODRIJETLOM IZ
BAKTERIJE *ESCHERICHIA COLI***

MEĐUNARODNI DVOJNI DOKTORAT

Mentor:

Prof. Maureen Bain, Prof. Vladimir Mrljak,
Dr. Geert Bruggeman

Zagreb, 2022



University of Zagreb



University
of Glasgow

Faculty of Veterinary Medicine.

Institute of Biodiversity, Animal health &
Comparative Medicine

Applying an Omics approach to investigate the effects of citrus and cucumber supplementation on broiler chickens under control and *Escherichia coli* LPS challenge conditions

Dissertation
for the degree of
Doctor of Philosophy (Ph.D.)

Faculty of Veterinary Medicine of the Sveučilišta u Zagrebu
&
Institute of Biodiversity, Animal health & Comparative Medicine of the University
of Glasgow

By

Francesca Riva

From
Milan, Italy

Glasgow, 2022

Author's Declaration

This thesis was conducted from October 2018 to May 2022 under the supervision of Professor Maureen Bain of the University of Glasgow, Professor Vladimir Mrljak of the university of Zagreb and Nutrition Science company in Belgium. The work presented in this thesis was performed solely by the author except where the assistance of others has been acknowledged, particularly Professor P. David Eckersall of the University of Glasgow, on proteomics and acute phase proteins interpretation described in chapter 3 and 4. Also, Dr David Mc Guinness assisted with the microbiota analysis described in chapter 2. The Life Diagnostics team of Dr Chris Chadwick supervised the APPs research described in chapter 3. The team of Professor Vladimir Mrljak of the University of Zagreb enabled use of Omics instruments and helped with the analysis required for the proteomics and metabolomics investigations described in chapter 5 and 6.

Francesca Riva

June 2022

Abstract

The overall aim of this thesis was to apply an OMICs approach to investigate the various effects of broiler diets supplemented with citrus or cucumber plant extracts under control and *Escherichia coli* LPS challenge conditions. Our overall hypothesis was that these diets conferred an advantage over the normal diet in terms of performance and resilience to a toxic challenge mimicking a gram-negative infection.

To investigate this, samples were collected from two in vivo trials on broiler chickens which were performed at the Cochno farm facilities at the University of Glasgow. The first dietary trial (10birds x 4replicates x 3diets) is described in Chapter 2 and was carried out to test the hypothesis that a baseline diet (CTL) supplemented with citrus (CTS) or cucumber (CMB) extracts improves the gut health of broiler chickens through the modulation of the gut microbiota leading to improved growth performance over a period of 28d. The second dietary trial (12 birds x4 replicates x3 diets) was performed to test the effects of CTL, CTS and CMB diets on the acute phase response (APR) of broiler chickens, in terms of a range of acute phase proteins (APPs) plasma biomarkers (traditional and novel) (chapter 3). The APR to an *E. coli* LPS challenge at 15d old was monitored in plasma and tissues over a period of 48h using different sampling time points (T0,12,24,48h) pre and post challenge as a means of gauging whether this response was altered by the extract diets, this included study of the proteome of liver and muscle (described in chapter 4) and the metabolome of liver and muscle (described in chapters 5 and 6).

For the microbiota investigation (Chapter 2), performance data and tissue samples were collected to evaluate the gut health of broilers on CTL, CTS or CMB dietary administration. Data on body weight (BW), feed intake (FI) and feed conversion ratio (FCR) were collected at day 0,7,14,21 and 28d of age to evaluate growth performance, while gut samples were collected at 14 and 28d of age to study the effects diet on the gut microbiota composition and gut morphology (villus length, epithelium height and crypt depth). In this study neither CTS nor CMB diets showed any difference in gut morphometric measurements or significant improvement in growth performance. Likewise dietary treatment had little or no effect on the overall bacterial taxonomy of either the jejunum or caeca, but subtle and potentially beneficial treatment effects were revealed in terms of the abundance of certain bacterial strains in one or both tissues. These results suggest that the use of citrus and cucumber extracts in broilers diet produce only very subtle effects in terms of promoting gut health in broiler chickens.

The following chapters 3,4,5 and 6 used data and samples collected from trial 2 where broilers underwent LPS challenge at 15d old. In Chapter 3, the APR response of broilers was evaluated in plasma samples using two established Acute Phase Proteins (APPs) biomarkers (Alpha 1 acid glycoprotein (AGP) and Serum amyloid A (SAA) and three novel APPs (Hemopexin (Hpx), Extracellular fatty acid binding protein (Ex-FABP), and MRP-126) at T0,12,24 and 48h pre and post LPS challenge. SAA, AGP, Ex-FABP and Hpx concentration were evaluated using the enzyme-linked immunosorbent (ELISA) assay while MRP-126 was measured using a novel SPARCLTM assay. No dietary modulation of the APR was identified in terms of either the novel or established APPs despite there being a strong LPS influence on their relative abundance at either 12 or 24h post challenge. While SAA showed the greatest response, Ex-FABP showed a strong response to LPS at 12h, and we believe can be classified as a major APP. While both Hpx and AGP peaked at 24h post challenge they were classified as moderate APPs. The results for MRP-126 were inconclusive and suggested that the diagnostic assay requires further refinement.

In Chapter 4, I report the proteomic investigation of liver and muscle samples collected from broilers fed each dietary treatment pre (T0) and T12h post LPS challenge. The LPS challenge caused an increase in abundance of a range of liver proteins including so called heat shock proteins (Hsps) at T12h. Interestingly no effects of LPS were observed in muscle. In terms of dietary treatment, the CTS diet revealed promising results in terms of modulating the APR post LPS challenge in that those proteins associated with heat stress were less abundant (e.g. < Hsp90), whilst others associated with accelerated metabolism were increased in liver (e.g. > lactate dehydrogenase (LDHA) and muscle (e.g. > Glyceraldehyde-3-Phosphate Dehydrogenase (GAPDH)) compared to the CTL samples. Western Blot (WB) validation for 3 selected proteins (HSP90, LDHA and GAPDH) was inconclusive, so at best it can be concluded that the CTS dietary effect was subtle but promising. Only minor dietary effects were revealed for tissues obtained from the CMB dietary treatment.

In Chapter 5 and 6, plasma and liver samples from all dietary treatments, pre (0h) and post LPS challenge (12,24 and 48h), were analysed using Untargeted metabolomics with one pooled study on plasma comparing all dietary treatments and 1 individual sample study on plasma comparing CTL and CTS only, and 1 pooled study on liver comparing all dietary treatments. The pooled studies were based samples from pens 1-12, diets (CTL, CTS and CMB) and LPS challenge time points (0,12,24 and 48h) while the complete study only compared individual samples from the CTL and CTS diets as the CMB diet did not show any metabolome/metabolites modulation in the pooled pilot study. These pilot studies

revealed that the overall plasma and liver metabolome were modulated by the LPS challenge over the 48h with the biggest change found at 12h post challenge. In particular the CTS diet showed a strong modulation of adenosine, along with multiple amino acid, carbohydrate, and nucleotide metabolic pathways all of which again suggest a modulation of the immune response for CTS.

In summary, this thesis applied an Omics approaches to investigate the use of novel plant extracts in the diet of broiler chickens. While there are some potential beneficial effects of these dietary treatments, especially CTS, further study of some of the latter's individual constituents seems warranted.

Extended abstract

Introduction and objective

Novel plant extracts, citrus and cucumber, were identified as possible alternatives to antibiotic growth promoters in broiler diets (Savoia, 2012). The presence of active compounds in citrus and cucumber makes them potential candidates for modulation of the immune system, bacteria, proteins and metabolites of broilers (Ndayishimiye et al., 2018; Goliomytis et al., 2019; Nema et al., 2011; Tang et al., 2010). Omics technologies can be used to explore these interactions in detail. The overall aim of this PhD was to apply an OMICs approach to investigate the effects of broiler diets supplemented with citrus or cucumber plant extracts under control and *Escherichia Coli* LPS challenge conditions. To investigate this aim, the following studies were conducted 1. An investigation of the microbiota composition and growth performance of broilers in response to experimental dietary supplementation with citrus or cucumber plant extracts 2. A study comparing the APR of broiler chickens which have been fed on one or other of these dietary regimes using existing and novel Acute Phase Protein Biomarkers pre and post being subjected to LPS challenge 3. A proteomic and metabolomic investigation of two key tissues (liver and muscle) sampled from broilers pre and post LPS challenge that had been fed diets supplemented with either citrus or cucumber extracts.

Materials and methods

Samples were collected from two in vivo trials on broiler chickens which were performed at the Cochno farm facilities at the Glasgow university. The first dietary trial (10birds x 4replicates x 3diets) was carried out to test the hypothesis that a baseline diet (CTL) supplemented with citrus (CTS) or cucumber (CMB) extracts improves the gut health of broiler chickens through the modulation of the gut microbiota leading to improved growth performance over a period of 28 days. The second dietary trial (12birds x4replicates x3diets) was performed to test the effects of CTL, CTS and CMB diets on the APR of broiler chickens, in terms of a range of APP plasma biomarkers (traditional and novel), the proteome of liver and muscle, and the metabolome of liver and muscle pre and post *E. coli* LPS challenge at 15 days old. The APR response was monitored in plasma and tissues over a period of 48 hours using different sampling time points (T0,12,24,48h) pre and post challenge.

For the microbiota investigation, performance data and tissue samples were collected to evaluate the gut health of broilers on CTL, CTS or CMB dietary administration. Data on

body weight (BW), feed intake (FI) and feed conversion ratio (FCR) were collected at day 0,7,14,21 and 28 days of age to use to evaluate growth performance while gut samples were collected at 14- and 28-days of age to study the effects diet on the gut microbiota composition and gut morphology (villus length, epithelium height and crypt depth). the DNA of each sample was extracted using the DNeasy PowerSoil Pro kit (Qiagen, Manchester, UK) and amplified by a 2-step 16S specific-PCR which used the V3-V4 region as target (Bukin et al., 2019). Following the PCR, the amplicons were quantified and diluted to an equimolar concentration, the Illumina library was prepared, and samples sequenced using the Illumina MiSeq platform (Illumina, San Diego, CA, USA). Once sequences were obtained, they were then analysed using QIIME Software v2. α and β diversity analysis was used to study respectively the within and among samples diversity. Linear discriminant analysis effect size (LEfSE) was used to identify specific bacterial strains in samples of the bacterial community modulated by one of the experiment variables (e.g diet, tissue, bird age).

Plasma and tissue samples from trial 2, where broilers underwent LPS challenge at 15 days old, were used for the APPs, proteome and metabolome investigations.

The APR response of broilers was evaluated in plasma samples using two established Acute phase proteins (APPs) biomarkers (AGP and SAA) and three novel APPs (Hpx, Ex-FABP and MRP-126) at T0,12,24 and 48 hours pre and post LPS challenge. SAA, AGP, Ex-FABP and Hpx concentration were evaluated using the ELISA assay while MRP-126 was measured using a novel SPARCL™ assay. Proteins of interest were validated using the Western blot (WB) procedure.

Two proteomics studies were performed to evaluate both the effects of CTS and CMB vs CTL diets at T12h post LPS challenge, and the effect of LPS challenge during the first T12h post challenge in CTL, on the liver and muscle of broilers. Samples were extracted, quantified in their total protein concentration by bicinchoninic acid (BCA) assay and then processed by trypsin digestion using the filter assisted sample preparation (FASP) protocol and tandem mass tag (TMT) labelling. High resolution LC-MS/MS analysis of TMT-labelled peptides was performed and acquired MS/MS spectra were analysed for protein identification and quantification using the SEQUEST algorithm implemented into Proteome Discoverer. Statistical analyses were performed in RStudio. UniProtKB ID mapping tool and DAVID conversion tool were used to convert GI accession numbers into official gene

symbol. Gene ontology enrichment analysis was performed using Protein Analysis Through Evolutionary Relationship (PANTHER) classification tool.

Three untargeted metabolomics studies (LC-MS based) were performed on plasma and liver samples from all dietary treatments, pre (0h) and post LPS challenge (12,24 and 48 hours) (1 pilot study on plasma comparing all dietary treatments, 1 complete study on plasma comparing CTL and CTS only, and 1 pilot study on liver comparing all dietary treatments). In the pilot studies, samples were pooled based on pen (1-12), diet (CTL, CTS and CMB) and LPS challenge time points (0,12,24 and 48 hours) while the complete study compared unpooled samples from the CTL and CTS diets only as CMB diet didn't show any metabolome/metabolites modulation in the pooled pilot study plasma. In all the three studies, samples were extracted using chloroform/methanol/water (1:3:1) and separated by liquid chromatography (LC) before the MS identification. Data obtained from MS were investigated using Polyomics integrated Metabolomics Pipeline (PiMP), which identifies metabolites, and MetaboAnalyst which allows statistical analysis. The last stage of analysis includes the biological interpretation of the results and discussion.

Results

Focusing on trial 1, CTS and CMB diets didn't show commercially valuable results in terms of improving growth performance and there was no difference in gut morphometric measurements. Likewise dietary treatment had little or no effect on the overall bacterial taxonomy of either the jejunum or caecum, but subtle and potentially beneficial treatment effects were revealed in terms of the abundance of certain bacterial strains in both jejunum and caecum. The biggest effect was found associated with the use of CTS where a number of beneficial bacteria including Lactobacilli increased in the jejunum, and Blautia increased in the caeca. Other potential pathogenic bacteria decreased in the jejunum (Enterococcus and Clostridia) and caeca (Enterococcus). These results suggest that the use of citrus and cucumber extracts in broilers diet produce very subtle effects in terms of promoting gut health in broiler chickens.

Based on trial 2 and the LPS challenge, no dietary modulation of the APR was identified in terms of either the novel or established APPs despite there being a strong LPS influence on their relative abundance at either 12 or 24 hours post challenge. Ex-FABP showed a very strong response to LPS at 12 hours, comparable to SAA. Under these experimental conditions Ex-FABP can therefore be classified as a major APP. Hpx was comparable to

AGP peaking at 24 hours post challenge and can therefore be classified as moderate APPs under these experimental conditions. Unfortunately, the results for MRP-126 were inconclusive and suggested that the diagnostic assay requires further refinement.

In the proteomics investigation, the LPS challenge was found to cause an increase in abundance of a range of proteins in the liver including heat shock proteins (HSPs) and actin at T12h. Interestingly no effects of LPS were observed in muscle. In terms of dietary treatment, the CTS diet revealed promising results in terms of the APR in that proteins associated with heat stress were less abundant (e.g. < HSP90), whilst others associated with accelerated metabolism were increased in liver (e.g. > lactate dehydrogenase (LDHA) and muscle (e.g. > Glyceraldehyde-3-Phosphate Dehydrogenase (GAPDH)) compared to the CTL samples post LPS challenge. These differences however could not be fully validated using Western Blot (WB) and so at best it can be concluded that the CTS dietary effect was subtle. No dietary effects were revealed for tissues obtained from the CMB dietary treatment.

Based on metabolomics results, the pilot studies revealed that the overall plasma and liver metabolome were modulated by the LPS challenge as anticipated at all time points with the biggest change occurring at 12 hours post challenge causing a decrease in the abundance of multiple amino acids, carbohydrates and causing significant changes to entire pathways. Comparing dietary treatments, CTS diet was the only treatment which showed potentially interesting results with a strong modulation for adenosine pre and 12 hours post LS challenge in the plasma. A possible interaction between the bioactive compounds in the CTS diet (i.e. pectin, flavonoids, limonene) and adenosine was subsequently hypothesised and investigated but not proven. Adenosine, along with multiple amino acid, carbohydrate, and nucleotide metabolic pathways were also shown to be influenced by CTS dietary administration (mainly increasing their intermediates) in the liver. Future work should focus on investigating the significance of the CTS modulation of adenosine a compound which is known to play an important role in the modulation of the immune system in humans and animals.

Conclusion

These studies described are aimed to evaluate the effects of two novel plant extracts, (CTS and CMB) on broiler performance during normal physiological conditions and also following an LPS challenge condition. These two novel extracts were chosen on the recommendation of our industry partner NuScience who reported that because of their

bioactive components showed considerable promise as alternatives to the use of antibiotics as growth promoters in broiler diets. Based on our experimental findings, while there are some potential beneficial effects of these dietary treatments, especially CTS, further study of some of the latter's individual constituents seems warranted.

Extended abstract

Uvod i ciljevi

Novi biljni ekstrakti, limuna i krastavca, ustanovljeni su kao moguće alternative antibiotskim poticateljima rasta u obrocima tovnih pilića (Savoia, 2012). Prisustvo aktivnih tvari u limunu i krastavcu čini ih potencijalnim kandidatima za modulaciju obrambenog sustava, bakterija, proteina i metabolita tovnih pilića (Ndayishimiye i sur. 2018.; Goliomytis i sur., 2019.; Nema i sur., 2011.; Tang i sur., 2010). Omika tehnologije mogu biti upotrebljene za detaljno istraživanje ovih interakcija. Cilj ovog doktorskog rada bio je primjena OMICa pristupa istražiti učinke obroka tovnih pilića s dodatkom biljnih ekstrakta limuna i krastavaca u odnosu na kontrolnu skupinu i tretman s LPS-om podrijetlom od bakterije *Escherichia Coli*. Da bi istražili ovaj cilj, provedena su sljedeća istraživanja: 1) Istraživanje sastava mikrobiote i učinaka rasta tovnih pilića kao odgovor na eksperimentalno dodavanje obroku biljnih ekstrakata limuna i krastavca; 2) Istraživanje uspoređujući APR tovnih pilića koji su hranjeni s jednim ili drugim obročnim tretmanom, primjenom postojećih i novih biomarkera proteina akutne faze prije i poslije izlaganja LPSom; 3) Proteomska i metabolomska istraživanja dvaju ključnih tkiva (jetre i mišićja) uzorkovana od tovnih pilića prije i poslije izlaganja LPSom koji su hranjeni obrocima koji su obogaćeni bilo ekstraktima limuna ili krastavaca.

Materijali i metode

Uzorci su sakupljeni u dva *in vivo* pokusa na tovnim pilićima koji su provedeni na Cochno farmi Sveučilišta u Glasgou. Prvo istraživanje (10 pilića x 4 ponavljanja x 3 obročna tretmana) provedeno je kako bi se testirala hipoteza da osnovna prehrana (CTL) dopunjena s ekstraktom limuna (CTS) i krastavca (CMB) poboljšava zdravlje crijeva tovnih pilića modulirajući crijevne mikrobiote što dovodi do poboljšanja rasta tijekom razdoblja od 28 dana. Drugo istraživanje (12 pilića x 4 ponavljanja x 3 obročna tretmana) provedeno je kako bi se testirali učinci CTL, CTS i CMB u obroku na APR tovnih pilića, u smislu vrijednosti APP biomarkera u plazmi (tradicionalnih i novih), proteoma jetre i mišića, i metaboloma jetre i mišića prije i poslije izlaganja LPSom, 15. dana starosti. APR odgovor je praćen u plazmi i tkivu tijekom perioda od 48 sati korištenjem raznih vremenskih točaka uzorkovanja (T0, 12, 24, 48) prije i poslije izlaganja LPSom.

Za istraživanje mikrobiote crijeva prikupljeni su podaci o performansama i uzorcima tkiva kako bi procijenili zdravlje crijeva tovnih pilića na CTL, CTS ili CMB prehrani. Da bi procijenili performanse rasta sakupljeni su podaci o tjelesnoj težini (BW), unosu hrane (FI) i konverziji hrane (FCR) 0, 7, 14, 21, i 28 dana starosti, dok su uzorci crijeva prikupljeni 14

i 28 dana starosti da bi istražili obroka na mikrobiotu crijeva i morfologiju crijeva (dužinu vila, visinu epitela i dubinu kripte). DNA svakog uzorka ekstrahiran je pomoću DNeasy PowerSoil Pro kita (Qiagen, Manchester, UK) i umnožen dvostupanjskim 16S specifičnim PCR-om koji je koristio V3-V4 regije kao metu (Bukin i sur., 2019). Nakon PCR-a, ampliconi su kvantificirani i razrijeđeni do ekvimolarne koncentracije, Illumina biblioteka je pripremljena, a uzorci su sekvencirani korištenjem Illumina MiSeq platforme (Illumina, San Diego, CA, SAD). Nakon što su dobivene sekvence, analizirane su pomoću QIIME softvera v2. α i β analiza raznolikosti korištena je za proučavanje raznolikosti, odnosno unutar i među uzorcima. Veličina učinka linearne diskriminacijske analize (LEfSE) korištena je za identifikaciju specifičnih bakterijskih sojeva u uzorcima bakterijske zajednice modulirane jednom od eksperimentalnih varijabli (npr. prehrana, tkivo, dob peradi).

Uzorci plazme i tkiva iz pokusa 2, gdje su tovnji pilići bili podvrgnuti LPS-u u dobi od 15 dana, korišteni su za istraživanja APP-a, proteoma i metaboloma.

APR odgovor tovnih pilića procijenjen je u uzorcima plazme pomoću dva dokazana biomarkera proteina akutne faze (APP) (AGP i SAA) i tri nova APP (Hpx, Ex-FABP i MRP-126) i to na T0, 12, 24 i 48 sati prije i nakon LPS izazova. Koncentracija SAA, AGP, Ex-FABP i Hpx procijenjena je pomoću ELISA testa, dok je MRP-126 mjereno pomoću novog SPARCLTM testa. Proteini od interesa potvrđeni su korištenjem Western blot (WB) metode.

Provedene su dvije proteomske studije kako bi se procijenili učinci CTS i CMB naspram CTL obroka, i to T12h nakon izlaganja LPS-u, i učinak LPS izlaganja tijekom prvog T12h nakon izlaganja CTL-u, na jetru i mišiće tovnih pilića. Uzorci su ekstrahirani, kvantificirana njihova ukupna koncentracija proteina kvantificirana je primjenom metode bicinhoninske kiseline (BCA), a zatim obrađeni digestijom tripsinom korištenjem protokola pripreme uzorka uz pomoć filtera (FASP) i označavanja putem izobarnih privjesaka (TMT). Provedena je LC-MS/MS analiza visoke rezolucije TMT-obilježenih peptida i analizirani su dobiveni MS/MS spektri za identifikaciju i kvantifikaciju proteina korištenjem SEQUEST algoritma implementiranog u Proteome Discoverer. Statističke analize rađene su u programu RStudiu. UniProtKB alat za mapiranje ID-a i alat za pretvorbu DAVID korišteni su za pretvaranje GI pristupnih brojeva u službeni simbol gena. Analiza obogaćivanja genske ontologije provedena je korištenjem alata za klasifikaciju analize proteina kroz evolucijski odnos (PANTHER).

Tri neciljana metabolomska istraživanja (temeljena na LC-MSu) provedene su na uzorcima plazme i jetre iz svih obročnih skupina, prije (0h) i nakon LPS (12, 24 i 48 sati) (1 pilot studija na plazmi koja je uspoređivala sve obročne pristupe, 1 kompletna studija na plazmi koja uspoređuje samo CTL i CTS, i 1 pilot studija o jetri koja uspoređuje sve obročne skupine). U pilot studijama uzorci su objedinjeni na temelju skupina u kavezu (1-12), prehrane (CTL, CTS i CMB) i vremenskih točaka izlaganja LPS-u (0, 12, 24 i 48 sati), dok je cjelovita studija uspoređivala neobjedinjene uzorke iz CTL i CTS obročne skupine jer CMB obročna skupina nije pokazala nikakvu modulaciju metaboloma/metabolita u skupnoj plazmi u okviru pilot studije. U sve tri studije uzorci su ekstrahirani korištenjem kloroforma/metanola/vode (1:3:1) i odvojeni tekućinskom kromatografijom (LC) prije MS identifikacije. Podaci dobiveni iz MS-a istraženi su korištenjem programa Polyomics integriranog Metabolomics Pipeline-a (PiMP), koji identificira metabolite, i programa MetaboAnalysta koji omogućuje statističku analizu. Posljednja faza analize uključuje biološku interpretaciju rezultata i raspravu.

Rezultati

Usredotočujući se na prvo istraživanje, CTS i CMB obroci nisu pokazali komercijalno vrijedne rezultate u smislu poboljšanja rasta i nije bilo razlike u morfometrijskim mjerenjima crijeva. Isto tako, obročni tretman imao je mali ili nikakav učinak na ukupnu bakterijsku taksonomiju jejunuma ili cekuma, ali otkriveni su suptilni i potencijalno korisni učinci u smislu rasprostranjenosti određenih bakterijskih sojeva u jejunumu i cekumu. Najveći učinak je pronađen povezan s upotrebom CTS-a gdje se broj korisnih bakterija, uključujući *Lactobacilli*, povećao u jejunumu, a *Blautia* u cekumu. Ostale potencijalne patogene bakterije smanjene su u jejunumu (*Enterococcus* i *Clostridia*) i cekumu (*Enterococcus*). Ovi rezultati sugeriraju da upotreba ekstrakata limuna i krastavaca u prehrani tovnih pilića ima vrlo suptilne učinke u smislu poboljšanja zdravlja crijeva kod tovnih pilića.

Na temelju drugog istraživanja i primjene LPS-a, nije ustanovljena obročna modulacija APR-a u smislu novih ili etabliranih proteina akutne faze (APP) unatoč snažnom utjecaju LPS-a na njihovu relativnu koncentraciju 12 ili 24 sata nakon primjene LPSa. Ex-FABP pokazao je vrlo snažan odgovor na LPS nakon 12 sati, usporediv sa SAA. Pod ovim eksperimentalnim uvjetima Ex-FABP se stoga može klasificirati kao glavni APP. Hpx je bio usporediv s AGP-om, dostigavši vrhunac 24 sata nakon LPSa i stoga se može klasificirati kao umjereni APP u ovim eksperimentalnim uvjetima. Nažalost, rezultati za MRP-126 nisu bili uvjerljivi i sugerirali su da dijagnostički test zahtijeva daljnje usavršavanje.

U proteomskim istraživanjima, otkriveno je da LPS uzrokuje povećanje koncentracije niza proteina u jetri, uključujući proteine toplinskog stresa (HSP) i aktin u T12h. Zanimljivo je da nikakvi učinci LPS-a nisu primijećeni u mišićima. Što se tiče obročnog tretmana, CTS u obroku pokazao je obećavajuće rezultate u pogledu APR-a, naročito stoga što su proteini povezani s toplinskim stresom bili manje zastupljeni (npr. < HSP 90), dok su drugi povezani s ubrzanim metabolizmom bili povećani u jetri (npr. > laktat dehidrogenaza (LDHA)) i mišiću (npr. > gliceraldehid-3-fosfat dehidrogenaza (GAPDH)) u usporedbi s CTL uzorcima nakon izlaganja LPS-om. Te se razlike, međutim ne mogu u potpunosti potvrditi pomoću metode Western Blot (WB) pa se u najboljem slučaju može zaključiti da CTS u obroku ima suptilan utjecaj. Nisu otkriveni nikakvi učinci prehrane na tkiva dobivena obročnim tretmanom CMB-om.

Na temelju rezultata metabolomskih istraživanja, pilot studije su otkrile da su cjelokupni metabolom plazme i jetre modulirani LPS, kao što je predviđeno u svim vremenskim točkama, pri čemu se najveća promjena dogodila 12 sati nakon izazova uzrokujući smanjenje količine višestrukih aminokiselina, ugljikohidrata i uzrokujući značajne promjene u biološkim putevima. Uspoređujući obročne tretmane, CTS u obroku je jedini pokazao potencijalno zanimljive rezultate sa snažnom modulacijom za adenzin u plazmi prije i 12 sati nakon LPS. Moguća interakcija između bioaktivnih spojeva u CTS obroku (tj. pektina, flavonoida, limonena) i adenozina naknadno je pretpostavljena i istražena, ali nije dokazana. Adenzin, zajedno s metaboličkim putevima višestrukih aminokiselina, ugljikohidrata i nukleotida također su pokazali da su pod utjecajem davanja CTS u obroku (uglavnom povećanjem njihovih intermedijara) u jetri. Budući bi se rad trebao usredotočiti na istraživanje značaja CTS modulacije na adenzin, spoj za koji se zna da igra važnu ulogu u modulaciji imunološkog sustava kod ljudi i životinja.

Zaključak

Opisana istraživanja imala su za cilj procijeniti učinke dvaju novih biljnih ekstrakata (CTS i CMB) na performanse tovnih pilića tijekom normalnih fizioloških uvjeta i nakon izlaganja LPS-u. Ova dva nova ekstrakta odabrana su na preporuku našeg industrijskog partnera NuScience koji je izvijestio da su, zbog njihovih bioaktivnih komponenti, pokazali obećavajuće rezultate, kao alternativu korištenju antibiotika kao poticatelja rasta u hranidbi tovnih pilića. Na temelju naših eksperimentalnih nalaza, iako postoje neki potencijalni korisni učinci ovih obročnih tretmana, posebno CTS-a, daljnje proučavanje nekih pojedinačnih sastojaka potonjeg čini se opravdanim.

Contents

Author's Declaration	2
Abstract	3
Extended abstract	6
Extended abstract	11
Contents	15
List of Figures	20
List of Tables	24
Acknowledgements	26
List of Publications and Presentations	29
List of Abbreviations	31
Chapter 1 General introduction	35
1.1 The poultry industry	36
1.2 Disease and stress	38
1.2.1 The broilers innate immune system	39
1.2.2 <i>Escherichia coli</i> endotoxin (LPS challenge).....	40
1.3 Antibiotics as growth promoters and anti-microbial resistance (AMR)	41
1.4 Alternatives to antibiotic growth promoters in poultry feed	42
1.4.1 Novel plant extracts	43
1.5 Useful indicators or biomarkers of health and disease that can be used in dietary investigations	47
1.6 Microbiota.....	49
1.6.1 Methods of studying Microbiota.....	50
1.6.2 Broilers gut microbiota	51
1.7 Acute phase proteins in chickens (APPs)	54
1.7.1 Measuring APPs in chickens.....	55

1.7.2	Serum amyloid A (SAA).....	56
1.7.3	Alpha acid glycoprotein (AGP).....	56
1.7.4	Hemopexin (Hpx).....	56
1.7.5	Ex-fatty acid binding protein (Ex-FABP)	57
1.7.6	MRP-126.....	57
1.8	Proteomics.....	58
1.8.1	Methods of studying proteomics.....	58
1.8.2	Studying the Broilers Proteome.....	59
1.9	Metabolomics	62
1.9.1	Methods of studying Metabolomics	62
1.9.2	Investigating the Broilers Metabolome	64
1.10	Aims of thesis	65

Chapter 2 The effect of novel plant extracts on gut microbiota

assessed by 16s rRNA sequencing.....67

2.1	Introduction	68
2.2	Aims and Objective of the study	69
2.3	Materials and Methods	70
2.3.1	Trial 1 Experimental design	70
2.3.2	Growth performance	71
2.3.3	Tissue Sample collection	71
2.3.4	Gut morphometric measurements.....	72
2.3.5	Microbiota summary workflow	73
2.4	Results.....	79
2.4.1	Growth performance	79
2.4.2	Jejunum morphometric measurements.....	83
2.4.3	Jejunum Microbiota Taxonomy.....	85
2.4.4	Caeca Microbiota Taxonomy	86
2.4.5	Dietary effects on the jejunal microbiota	88
2.4.6	Dietary effects on the caecal microbiota	94
2.4.7	Comparison between jejunal and caecal microbiota.....	99
2.4.8	Effect of bird age on the jejunal microbiota (d14 and d28).....	103
2.4.9	Effect of bird age on the caecal microbiota (d14 and d28)	107

2.5	Discussion	111
-----	------------------	-----

Chapter 3 Novel biomarkers to assess the effect of novel plant extracts on the immune response pre and post LPS challenge 121

3.1	Introduction	122
3.1.1	Aims and Objective of the study	124
3.2	Materials and methods	125
3.2.1	Trial 2 Experimental design	125
3.2.2	LPS challenge and plasma collection	125
3.2.3	APP summary workflow	126
3.2.4	Statistical analysis for APPs	131
3.3	Result	132
3.3.1	Body weight and dietary treatment pre LPS challenge	132
3.3.2	Acute Phase Proteins	133
3.4	Discussion	147

Chapter 4 Proteomics on liver and muscle samples: effects of novel plant extracts following an LPS challenge..... 152

4.1	Introduction	153
4.1.1	Aims and Objective of the study	154
4.2	Materials and Methods	155
4.2.1	Proteomics: Summary workflow	155
4.2.2	Sample selection and preparation	156
4.2.3	BCA assay	157
4.2.4	FASP protocol	158
4.2.5	TMT labelling.....	159
4.2.6	LC-MS/MS analysis	160
4.2.7	Statistical analyses	161
4.2.8	Gene Ontology Enrichment Analysis	161
4.2.9	Validation of selected differentially expressed Proteins by the Western Blot procedure	161
4.3	Results	165
4.3.1	Summary of the effects of LPS on the liver and muscle proteome (CTL diet at T0h vs T12h)	165

4.3.2	Effect of diets on the liver and muscle proteome at T12h post challenge	173
4.3.3	Relevant findings in the liver and muscle proteome of broilers associated to LPS effect in CTL diet and CTS diet at 12h post challenge.....	188
4.3.4	Validation of liver proteins by Western Blot procedure	188
4.3.5	Validation of muscle proteins by Western Blot procedure	190
4.4	Discussion	192

Chapter 5 Metabolomics on plasma samples: effects of novel plant extracts pre and post LPS challenge 199

5.1	Introduction	200
5.2	Aims and Objective of the study	201
5.3	Materials and methods	202
5.3.1	Metabolomics: Summary workflow	202
5.3.2	Sample selection and preparation	203
5.3.3	LC-MS/MS analysis	204
5.3.4	Metabolite's identification Polyomics integrated Metabolomics Pipeline (PiMP)	206
5.3.5	MetaboAnalyst: statistical analysis	207
5.3.6	Follow-up functional study: Corticosterone assay.....	208
5.4	Results.....	210
5.4.1	Plasma metabolome	210
5.4.2	Characterising the LPS effect on the plasma metabolome of broilers at T0, T12, T24 and T48 post LPS challenge- CTL diet	210
5.4.3	Plasma metabolome: dietary effect	222
5.5	Functional study: Corticosterone assay	225
5.6	Discussion	226

Chapter 6 Metabolomics on liver pooled samples: effects of novel plant extracts pre and post LPS challenge 232

6.1	Introduction	233
6.2	Aims and Objective of the study	233
6.3	Materials and methods	234
6.3.1	Sample selection and preparation	234

6.3.2	Liver Untargeted Metabolomics workflow	234
6.4	Results	235
6.4.1	Pooled study on liver: LPS effect	235
6.4.2	Pooled study on liver: dietary effect	247
6.5	Discussion	262
Chapter 7	General discussion	266
7.1	Citrus and Cucumber extracts as antibiotics growth promoters' alternatives..	267
7.2	Effect of CTS and CMB diets on broilers under normal physiological conditions 267	
7.3	Effect of Citrus and Cucumber extracts on broilers under LPS challenge	270
7.4	Broilers immune response to LPS and discovery of new biomarkers	273
7.5	Conclusions	275
Appendices	277
Appendix A - Microbiota		278
QIIME™ scripts		278
Appendix B - Proteomics		280
Appendix C- Metabolomics		284
Pooled study on plasma: LPS effect		284
Pooled study on plasma: dietary effect		288
Pooled study on liver		295
References		298
Websites		323

List of Figures

Figure 1.1 Worldwide meat production (modified from https://ourworldindata.org/meat-production).....	36
Figure 1.2 Comparison of Body weight, FCR and body conformation of broilers at 35d of age from 1995-2020 (modified from Siegel, 2014).....	37
Figure 1.3 Acute phase response in chickens and associated outcomes	41
Figure 1.4 Bacterial 16S ribosomal RNA (rRNA) gene	51
Figure 2.1 Morphometric measurements carried out on histological sections of the Jejunum	73
Figure 2.2 Pipeline of the microbiota investigation	74
Figure 2.3 16S Illumina Sequencing Library preparation workflow	76
Figure 2.4 Body weight (Kg) of broilers on CTL, CTS and CMB supplemented diets at 0,7,14,21,28d of age	80
Figure 2.5 FI (Kg) of broilers on CTL, CTS and CMB supplemented diets at 7,14,21,28d of age	81
Figure 2.6 FCR of broilers by diet (A) and bird age (B).....	82
Figure 2.7 Taxonomy (phylum level) comparison of CTL, CTS and CMB diets in jejunum samples collected from broilers at 14 and 28d old	85
Figure 2.8 Taxonomy (family level) comparison of CTL, CTS and CMB diets in jejunum samples collected from broilers at 14 and 28d old	86
Figure 2.9 Taxonomy (phylum level) comparison for CTL, CTS and CMB diets in the caeca of broilers sampled at 14 and 28d old.....	87
Figure 2.10 Taxonomy (family level) comparison for CTL, CTS and CMB diets in the caeca of broilers sampled at 14 and 28d old.....	88
Figure 2.11 Dietary effect on microbiota diversity in the jejunum	90
Figure 2.12 LEfSe - bacteria modulated by CTS diet in the jejunum	93
Figure 2.13 Dietary effect on microbiota diversity in the caeca	95
Figure 2.14 LEfSe - bacteria modulated by CTS in the caeca.....	97
Figure 2.15 LEfSe – bacteria modulated by CMB in the caeca	98
Figure 2.16 Tissue effect (jejunum vs caeca) on β -diversity	101
Figure 2.17 LEfSe – bacterial differences between tissues (jejunum vs caeca)	102
Figure 2.18 Bird age effect on diversity in the jejunal microbiota	105
Figure 2.19 LEfSe – bacteria modulated by bird age in the jejunum.....	106
Figure 2.20 Bird age effect on diversity in the caecal microbiota	108

Figure 2.21 LEfSe – bacteria modulated by bird age in the caeca.....	110
Figure 3.1 Immunoassays (ELISA and SPARCL™) used to analyse the APPs.....	126
Figure 3.2 Example of standard curve obtained from the Optima software (AGP assay).128	
Figure 3.3 Example of standard curve obtained from the Optima software (SAA assay).129	
Figure 3.4 Table and scatter plot of AGP concentration based on different diets (CTL CTS, CMB) pre (T0) and post (T12, T24, T48) challenge	134
Figure 3.5 Table and scatter plot of AGP concentration based on LPS challenge at T0 .	135
Figure 3.6 Table and scatter plot of SAA concentration based on different diets (CTL CTS, CMB) pre (T0) and post (T12, T24, T48) challenge	137
Figure 3.7 Table and scatter plot of SAA concentration based on LPS challenge at T0 .	138
Figure 3.8 Table and scatter plot of Ex-FABP concentration based on different diets (CTL CTS, CMB) pre (T0) and post (T12, T24, T48) challenge	140
Figure 3.9 Table and scatter plot of Hpx concentration based on different diets (CTL CTS, CMB) pre (T0) and post (T12, T24, T48) challenge	142
Figure 3.10 Table and scatter plot of Hpx concentration following LPS challenge at T0	143
Figure 3.11 Table and scatter plot of MRP-126 concentration based on different diets (CTL CTS, CMB) pre (T0) and post (T12, T24, T48) challenge	145
Figure 3.12 Table and scatter plot of MRP-126 concentration following LPS challenge at T0	146
Figure 4.1 Samples preparation for protein quantification using Tandem mass Tag (TMT) plex and MS used for our proteomics investigation	155
Figure 4.2 Samples used for proteomics study 1 and 2	156
Figure 4.3 BCA assay: standard curves of liver and muscle samples of the first proteomics study	158
Figure 4.4 Example of workflow summary using the Thermo Scientific TMT sixplex Isobaric Mass Tagging Reagents	159
Figure 4.5 Volcano plots comparing liver proteome at T0h and T12h post LPS challenge	169
Figure 4.6 Heat maps of liver proteome in samples collected at T0h and T12h post LPS challenge.....	170
Figure 4.7 GO slim analysis of differentially expressed liver proteins at T0h and T12 post	172
Figure 4.8 Volcano plots comparing liver proteome in CTS vs CTL diet at T12h post LPS challenge.....	177

Figure 4.9 Heat maps of liver proteome in samples of CTS vs CTL diet at T12h post LPS challenge.....	178
Figure 4.10 GO slim analysis of differentially expressed liver proteins in CTS vs CTL diet at T12 post LPS challenge	180
Figure 4.11 Volcano plots comparing muscle proteome in CTS vs CTL diet at T12h post LPS challenge	184
Figure 4.12 Heat maps of muscle proteome in samples of CTS vs CTL diet at T12h post LPS challenge	185
Figure 4.13 Gene ontology terms of differentially expressed proteins associated with the muscle proteome in CTS vs CTL diet at T12h post LPS challenge	187
Figure 4.14 LDHA and Hsp90 gels of liver samples comparing CTL T0 vs CTL T12 (gel 1), CTL T12 vs CTS T12 (gel 2), CTS T0 vs CTS T12 (gel 3) and CTL T0 vs CTS T0 (gel 4)	189
Figure 4.15 LDHA and Hsp90 abundances in liver samples comparing CTL T0 vs CTL T12 (gel 1), CTL T12 vs CTS T12 (gel 2), CTS T0 vs CTS T12 (gel 3) and CTL T0 vs CTS T0 (gel 4).....	190
Figure 4.16 GAPDH gel of muscle samples comparing CTL T12 vs CTS T12.....	191
Figure 4.17 GAPDH abundances in muscle samples of CTL T12 vs CTS T12.....	191
Figure 5.1 Workflow of LC-MS based Untargeted Metabolomics	202
Figure 5.2 Pooling of samples for Untargeted metabolomics analysis in broilers fed with cucumber diet as an example.	203
Figure 5.3 Minimum/maximum and interquartile range of the TIC signals for the positive mode pooled samples showing high reproducibility of the instrument over time. ..	205
Figure 5.4 Minimum/maximum and interquartile range of the TIC signals for the negative mode pooled samples showing high reproducibility of the instrument over time. ..	205
Figure 5.5 KEGG pathways influenced by LPS challenge.	219
Figure 5.6 PCA and PLSDA of samples belonged to CTL diets at time points 0,12,24 and 48h pre and post challenge.....	220
Figure 5.7 Cysteine, Methionine, Citrate and (S)- Malate, pre (T0h) and post (T12,24,48h) LPS challenge in CTL diet.....	221
Figure 5.8 PCA and PLSDA of samples belonged to CTS and CTL diets at time points 0,12,24 and 48h pre and post challenge.....	223
Figure 5.9 Adenosine intensity of samples at T0,12,24 and 48 in CTL and CTS diets ..	224
Figure 5.10 Adenosine production during inflammation or as a result of stress.....	228

Figure 5.11 Interaction between CTS compounds (quercetin, hesperidin, and limonene), adenosine and its receptors A1, A2A, A2B, A3.	230
Figure 6.1 KEGG pathways influenced by LPS challenge at T12h compared to pre challenge at T0h	244
Figure 6.2 PCA and PLSDA of samples belonged to CTL diets at time points 0,12,24 and 48h pre and post challenge.....	245
Figure 6.3 Cysteine, Methionine, Arginine and Proline, pre (T0h) and post (T12,24,48h) LPS challenge in CTL diet	246
Figure 6.4 KEGG pathways influenced by CTS diet at 12h post challenge	257
Figure 6.5 PCA and PLSDA of samples belonged to CTS and CTL diets at T0, T12, T24, T48h pre and post challenge.	259
Figure 6.6 Cysteine, Methionine, Arginine, Proline and Citrate pre (T0h) and post (T12,24,48h) LPS challenge.....	260
Figure 6.7 Adenosine intensity of samples at T0,12,24,48 in CTS and CTL diets.	261

List of Tables

Table 2.1 Feed ingredients (g/100kg) of basal diet for broiler chickens	71
Table 2.2 Jejunum measurements (μm) of villus length, crypt depth and epithelium height at day 14 and 28 for each dietary treatment (CTL, CTS and CMB)	84
Table 2.3 Data of α -diversity analysis by comparing the effects of diets on the jejunum	89
Table 2.4 Data of α -diversity indices by comparing the effects of diets on the caeca	94
Table 2.5 Data of α -diversity analysis by comparing tissues (jejunum vs caeca)	99
Table 2.6 Data of α -diversity analysis by comparing birds ages (14 vs 28d old) in jejunum samples	103
Table 2.7 Data of α -diversity analysis by comparing birds age (14 vs 28d old) in caeca samples	107
Table 3.1 BW (Kg) of broilers on CTL, CTS and CMB supplemented diets at 0,8,15d of age	132
Table 3.2 Comparison of novel and established APPs in plasma	149
Table 4.1 Effects of LPS at T0h vs T12h post LPS challenge in the CTL diet.....	165
Table 4.2 Differentially expressed proteins ($p < 0.05$) at T0h vs T12h in liver samples collected from CTL diet pre and post LPS injection	168
Table 4.3 Effects of CTS diet on the liver and muscle proteome at T12h post LPS challenge.....	173
Table 4.4 Differentially expressed proteins ($p < 0.05$) in CTS vs CTL diet at T12h post LPS challenge in liver samples	176
Table 4.5 Differentially expressed proteins ($p < 0.05$) in CTS vs CTL diet at T12h post LPS challenge in muscle samples.....	183
Table 4.6 Summary of the key findings on the effects of LPS and CTS diet on liver and muscle proteome at T12h post LPS challenge.....	188
Table 5.1 LPS challenge: pairwise comparisons of T0h vs T12,24,48h and the respective metabolites annotated (assigned putatively on the basis of mass) and identified (matched by mass and retention time to standards) detected before and post peak and isoforms evaluation.	211
Table 5.2 Significant metabolites in CTL T0h vs CTL T12h in plasma samples	212
Table 5.3 Significant metabolites in CTL T0h vs CTL T24h in plasma samples	213
Table 5.4 Significant metabolites in CTL T0h vs CTL T48h in plasma samples	214

Table 5.5 Pairwise comparisons of CTL vs CTS diet at each time point (T0,12,24,48h) and the respective annotated and identified metabolites detected before and post peak and isoforms evaluation.	222
Table 5.6 Corticosterone concentrations (ng/ml) in plasma of broilers fed different dietary regimes at T0 (pre LPS challenge).....	225
Table 6.1 LPS challenge: pairwise comparisons of T0h vs T12,24,48h and the respective annotated and identified metabolites detected before and post peak and isoforms evaluation.	235
Table 6.2 Significant metabolites in CTL vs CTL diet in liver samples at T12h.....	237
Table 6.3 Significant metabolites in CTL vs CTL diet in liver samples at T24h.....	238
Table 6.4 Significant metabolites in CTL vs CTL diet in liver samples at T48h.....	238
Table 6.5 Pairwise comparisons of CTL vs CTS diet at each time point (T0,12,24,48h) and the respective annotated and identified metabolites detected before and post peak and isoforms evaluation.	247
Table 6.6 Significant metabolites in CTL T12h vs CTS T12h in liver samples	249

Acknowledgements

Working as a PhD student has been a magnificent as well as challenging experience. Along this journey, many people have contributed, directly or indirectly, in shaping up my researcher career. It would have never been possible to conclude this doctoral work without the precious support of all these people together.

First of all, I would like to thank my supervisor Professor Maureen Bain for giving me the opportunity to undertake this PhD program. I have grown up a lot during these years, not just professionally but also personally and I have enjoyed this PhD so much that I can't even explain. My biggest gift has been to have such a great supervisor who has allowed me to approach this PhD in my own way giving the freedom to develop ideas but always guiding me on the right direction. From the first day, Maureen supported me throughout this process, and I have always had the feeling to be able to communicate with her about everything. She has always helped me to overcome difficulties urging me to do the best. I would not have been able to do this PhD and all the achievements without the guidance of the best supervisor I could ever asked for – Thank you Maureen from the bottom of my heart.

I would like also to express my gratitude to the MANNA project and the European Union's Horizon 2020 research and innovation programme for the financial support provided which allowed this PhD to become a reality. I would like to thank all the MANNA consortium for giving me the opportunity to complete an incredible experience between universities and companies that has allowed me to build a great scientific network. A special thanks to Professor David Eckersall who has been very supportive in helping me with the proteomics, acute phase proteins studies and the writing up of the thesis. David, you have been the reference point for all MANNA people, and an important stone of the success of the overall MANNA project. Professor Vladimir Mrljak who has welcomed me in his proteomics and metabolomics laboratory and have been very supportive with the Zagreb bureaucracy. I would like to thank Dr Mark McLaughlin who actively participated in my *in vivo* trials and offered his guidance on Western blot analysis. A big thank you to all my MANNA colleagues that have shared this journey with me, especially Morena Cau and Ruben Riosa who have been special companions of this Phd from the first day.

At the vet school in Glasgow, I would like to thank Dr Dorothy McKeegan for her support to perform the *in vivo* trials under her home office licence. Dr Neil Evans for helping me

with the corticosterone assay, Han Hanh for participating in the protein's validation procedure, Prof. David Logue for helping with the writing of the thesis. The technicians Ana Monteiro and Lynne Fleming for providing such a great technical support and advice from the start of this PhD. Dr Elisabetta Tolla who has not been just a colleague but a true friend that life has gifted me. I feel so blessed to have met you during my PhD; my journey would have not been the same without the time spent together inside and outside the office (although I will never forgive you for not inviting me to California two days after knowing each other). My writing pal Viola Farci that has been such a great friend from the first summer school; we have shared so many adventures and misfortunes that I feel so lucky to have met you.

At the Zagreb University, I would like to thank the research team of the Professor Vladimir Mrljak where I have had the pleasure to meet Josipa Kuleš, Ivana Rubić, Sudipa Maity and Tea Rakusa who have welcomed me in their research group and have been not only great colleagues in the lab but also special friends during my stay in Zagreb. Thanks to all of them I found again the positive energy, I was losing during the pandemic, to continue my PhD with higher and higher motivation.

I also would like to acknowledge the companies and labs in which I worked during this study. Dr Geert Bruggeman and David Hermans of the Nutrition Science company, for aiding me to formulate and prepare the diets used in the *in vivo* trials. Dr Chris Chadwick and Dr Laura Chadwick of the Life Diagnostics company for supervising my acute phase proteins research. Both companies have provided me a very pleasurable stay and the opportunity to undertake multiple training programmes. Dr Richard Burchmore and his colleagues Dr Gavin Blackburn, Dr Clement Regnault at Glasgow Polyomics who provided great advice and support for the metabolomics work and Dr David McGuinness who has guided me on the microbiota investigation. I would also like to the World Poultry Society and British Poultry Society that have financially supported part of my metabolomics and acute phase proteins work.

My family and partner have been a constant source of support and love over the years. My family who has always been by my side to support my decisions and help me to face the difficulties of these years. In particular, my mum has given me so much unwavering support and love to reach the end of this journey. Also my partner and best friend Pietro who has shared all this crazy adventure with me. He has been the most supportive person I could ever desired by my side during these years. He has helped me to go through the nightmare of this

thesis and I can admit that it has been a bit hard to bear with me. Thank you for your patience and love. I would have never achieved all this without you.

I want to thank all my friends all over the world who contribute to make me feel so alive and loved during these years. A special thanks to my always and forever friends in Italy, Serena, Sara, Ilaria, Eleonora, Andreana and Laura. You have been a fundamental part of this journey, the laugh and time spent together have been the energy and battery of this PhD. Finally, to my special friends in Glasgow, Giulia, Alessandro, Andrea, Elisabetta, Viola, Ramon and Sole, Ilaria; you have been my family over these years, and I have never felt alone even miles and miles away from home.

Love and thanks you all.

List of Publications and Presentations

Some of the work contained in this thesis has been the subject of, or is related to, the following publications or presentations:

Conference proceedings

2019 World's Poultry Science Association (WPSA) and British society of Animal Sciences (BSAS) annual conference, Edinburgh (UK).

2020 Marie Skłodowska-Curie Actions (MSCA) presidency videoconference impact of MSCA on career development for early-stage researchers, Zagreb (HR).

2020 71st annual meeting of European Federation of Animal Science (EAAP) Untargeted metabolomics: effects of novel plant extracts in broilers pre and post LPS challenge, Oporto (PT) (online).

2020 Spring annual meeting World's Poultry Science Association (WPSA) Untargeted metabolomics on plasma and liver samples: effects of novel plant extracts in broilers pre and post LPS challenge, Cambridge (UK) (online)

2021 72st annual meeting of European Federation of Animal Science (EAAP) The role of citrus and cucumber diets in chicken gut microbiota profile using 16s rRNA sequencing, Davos (CH).

2022 100st World poultry congress (WPC)

-Effect of two novel plant extracts (citrus and cucumber) on broiler chicken performance and gut microbiota, Paris (FR)

-Novel plant extracts in broiler diets: A proteomic investigation following an LPS challenge, Paris (FR)

2022 70th ASMS Conference on Mass Spectrometry and Allied Topics (ASMS)

Proteomics on liver and muscle samples: effects of novel plant extracts in broilers during lipopolysaccharide challenge conditions, Minneapolis (USA).

Summer schools and events

2018 Summer school “Introduction to Omics”, Glasgow (UK)

2019 Summer school on Omics, Milan (IT)

2019 European researchers' night: Explorathon, Glasgow (UK)

2020 Bioinformatics summer school, Kosice (SK)

2020 Summer school in Omics, Dubrovnik (HR)

Awards & travel grants

2019 British Poultry society project grant

2020 WPSA annual Award - project grant

2020 MSCA award: impact of MSCA on career development for early-stage researchers

2021 Glasgow University travel grant

2022 Youth program World poultry congress (WPC)

2022 WPC travel grant

Funding

European Union’s Horizon 2020 research and innovation programme H2020-MSCA- ITN-2017- EJD: Marie Skłodowska-Curie Innovative Training Networks (European Joint Doctorate) – Grant agreement n°: 765423 – MANNA.

List of Abbreviations

%	Percent
+	Plus
±	Plus, minus
<	Less than
>	More than
1DE	One-dimensional
2D-DIGE	Differential gel electrophoresis
2DE	Two dimensional
ACN	Acetonitrile
ACTH	Adrenocorticotrophic hormone
AGP	Alpha 1 acid glycoprotein
ALB	Albumin
AMR	Antimicrobial resistance
ANOVA	Analysis of variance
AP	Acute phase
APP	Acute phase protein
APR	Acute phase response
ASRU	Animals in Science Regulation Unit
ATP	Adenosine triphosphate
BCA	Bicinchoninic acid
BNF	buffered-neutral formalin
BSA	Bovine serum albumin
BW	Body weight
Ca ²⁺	Calcium ion
CE	Capillary electrophoresis
CMB	Cucumber diet
CORT	Corticosterone
CRP	C-reactive protein
CTL	Control diet
CTS	Citrus diet
CV	Coefficient of variation
d	Days
DTT	DL-Dithiothreitol
EI	Electron impact ionisation
ELISA	Enzyme linked immunosorbent assay
ESI	Electrospray ionization
Ex-FABP	Extracellular fatty acid binding protein
FASP	Filter aided sample preparation
FC	Fold change
FCR	Feed conversion ratio
FDR	false discovery rate

FI	Feed intake
FOS	Fructooligosaccharides
g	Gram
g/L	Gram per litter
GAPDH	Glyceraldehyde-3-Phosphate Dehydrogenase
GC	Gas chromatography
GIT	Gastrointestinal tract
GO	Gene ontology
h	Hours
HILIC	hydrophilic interaction liquid chromatography
HPA	Hypothalamic-Pituitary-Adrenal
HPG	Hypothalamic-Pituitary-Gonadal
HPLC	High-performance liquid chromatography
Hpx	Haemopexin
HRP	Horseradish peroxidase
IB	Infectious bronchitis
IBDV	Infectious bursal disease virus
ID	Identification
IEC	Ion-Exchange Chromatography
IEF	Immunoelectrophoresis
Ig	Immunoglobulin
IIR	Innate immune response
IL	Interleukin
kDa	Kilo Dalton
KEGG	Kyoto Encyclopedia of Genes and Genomes
L	Litre
LC	Liquid chromatography
LC-MS/MS	Liquid chromatography-tandem mass spectrometry
LDA	Linear discriminant analysis
LDHA	Lactate dehydrogenase
LPS	Lipopolysaccharride
M	Molar
m/z	Mass to charge ratio
MALDI	Matrix-assisted laser desorption/ionization
MCP	Modified citrus pectin
MDL	Minimum detection limit
MHC	Major histocompatibility complex
Min	Minute
ml	Millilitre
mm	Millimetre
mM	Millimolar
MS	Mass spectrometry
MS/MS	Tandem mass spectrometry
Mw	Molecular weight

N=	Sample size
Na ₂ CO ₃	Sodium carbonate
NaCl	Sodium chloride
NaHCO ₃	Sodium bicarbonate
NaOH	Sodium hydroxide
NCP	Nitrocellulose paper
NGS	Next generation sequencing
NMR	Nuclear magnetic resonance
No.	Number
° C	Degrees Celsius
OTU	Operational taxonomic unit
Ovt	Ovotransferrin
p-value	Probability that null hypothesis is true
PAGE	Polyacrylamide gel electrophoresis
PANTHER	Analysis Through Evolutionary Relationship
PCA	Principal component analysis
pH	Power of hydrogen
PLSDA	Partial least squares discriminant analysis
QC	Quality control
QIIME	Quantitative Insights Into Microbial Ecology
QIT	Quadrupole ion trap
RA	Relative abundance
RFI	Residual feed intake
RFLP	Restriction fragment length polymorphism
RID	Radial immunodiffusion
ROS	Reactive oxygen species
RT	Room temperature
SAA	Serum amyloid A
SCFA	Short chain fatty acid
SD	Standard deviation
SDS	Sodium dodecyl sulphate
SDSPAGE	Sodium dodecyl sulfate polyacrylamide gel electrophoresis
SE	Standard error
SILAC	Stable isotope labelling with amino acids in cell culture
SPARCL TM	Spatial Proximity Analyte Reagent Capture Luminescence
SSCP	Single-strand conformation polymorphism
TBS	Tris-buffered saline
TBS-T	Tris-buffered saline with Tween 20
TEAB	Triethyl ammonium bicarbonate
TIBC	Total iron binding capacity
TIC	Total ion chromatogram
TLR	Toll like receptor
TMT	Tandem mass Tag
TNF	Tumour necrosis factor

TOF	Time of flight
TQ	Triple quadrupole
TTBS	Tris Buffer saline
V	Volt
vs.	Versus
WB	Western Blot
WHO	World Health Organization
µg	Microgram
µg/ml	Microgram per litre
µl	Microlitre

Chapter 1 General introduction

1.1 The poultry industry

The poultry industry has grown significantly over the last few decades due to genetic improvements, introduction of modern intensive production methods, improvement of preventive disease control and biosecurity measures (Ricke, 2018). The intense genetic selection for either rapid growth (meat production) or persistency in lay egg (egg production) has resulted in two separate industries: the broiler industry (meat types of chicken) and the table egg industry (commercial layers) (Alders et al., 2018; Karcher and Mench, 2018). The broiler industry will be the focus in this thesis.

In 2021, the world's broiler meat production amounted to about 102 million metric tons (<https://www.statista.com/statistics/237637/production-of-poultry-meat-worldwide-since-1990/>) and its production is predicted to increase in the following years. As a result of these advances, poultry meat is cheaper and is also considered healthier compared to the other meats (Figure 1.1) leading to a significant increase in its worldwide consumer demand (Marangoni et al., 2015).

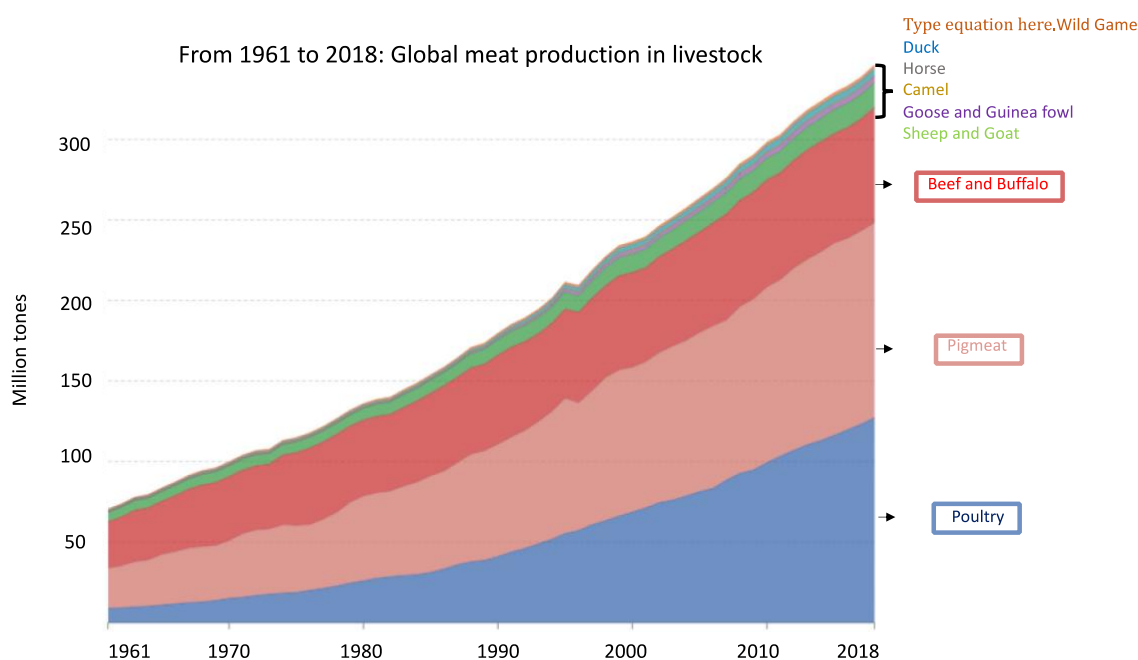

Figure 1.1 Worldwide meat production (modified from <https://ourworldindata.org/meat-production>)

Thus, broiler meat production is an increasingly important economic activity but there are concerns regarding the welfare of the birds and around the potential increase in zoonosis arising both directly from the birds or indirectly from the consumption of contaminated meat e.g. Campylobacteriosis driven by this maximisation of production efficiency in order to

produce cheap food (Meseret, 2016). The modern broiler chicken has been highly selected for growth rate and feed efficiency (Meseret, 2016). Growth rate is referred to the weight gain by broilers at their different age while feed efficiency is generally defined by feed conversion ratio (FCR) which is calculated by the amount of feed needed per kilogram of bodyweight gain (Aggrey et al., 2010). FCR should be as low as possible in order for a production unit to be commercially valuable as feed along with the cost of replacement stock are the key inputs involved in broiler production (Bai et al., 2022). These parameters can be influenced by different factors such as age, sex, health and environment (Leeson et al., 1995).

The body weight of a modern broiler at 35d of age is summarised in Figure 1.2 and can be seen to have increased steadily while FCR has been reduced dramatically (Siegel, 2014). In the same way, the body conformation has also changed dramatically by genetic selection and these differences have been recognised to be much greater in chicken's males than females (Zuidhof et al., 2014).

Year	Body weight (g)	FCR
1985	1.400	2.30
1990	1.700	2.26
1995	2.010	2.08
2000	2.140	1.96
2005	2.310	1.65
2010	2.440	1.50
2015	2.450	1.49
2020	2.484	1.46

1985  2020

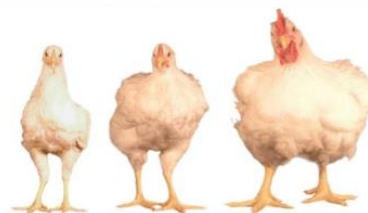

1Figure 1.2 Comparison of Body weight, FCR and body conformation of broilers at 35d of age from 1995-2020 (modified from Siegel, 2014).

Management practices have also had to change in order to capitalise on the potential benefits of new emerging genotypes; most commercial broilers are now raised entirely indoors and the current advances in sensing technology, allow for precise control of the production

environment (Sassi et al., 2016) in order to ensure flock uniformity and maximize production (Karcher and Mench, 2018). In addition, feed is formulated to meet the birds nutritional needs at each stage of its growth or production cycle and specific environmental conditions including the lighting and its intensity are carefully controlled to stimulate growth, or egg laying in the case of the parent stock (Thornton, 2010).

1.2 Disease and stress

Intensive farming practices create ideal conditions for parasite growth and disease transmission with the risk of epidemic outbreaks (Mennerat et al., 2010).

Infectious agents that can affect broiler production include bacteria, viruses, fungi, external parasites such as lice and mites and internal parasites such as worms, protozoa (Chaves, 2014). Among these, coccidiosis is an enteric disease which can cause a high level of mortality and can negatively impact production (Blake and Tomley, 2014). Once this disease occurs in the chicken's farm, it rapidly spreads and can infect 80% of the population (Fatoba and Adeleke, 2018). Many other factors can influence the health of chickens; in many cases of infection, the birds are affected subclinically yet are under stress leading to poor production (Chaves, 2014). For this reason, it is important to provide good housing conditions and avoid stressors that result in fear, malnutrition, dehydration, over-crowding, or extremes in climatic conditions (https://en.aviagen.com/assets/Tech_Center/Ross_Broiler/Ross-BroilerHandbook2018-EN.pdf).

Stress can be defined as any condition which causes allostatic load to an organism, e.g. an increase in the cost of maintaining physiological homeostasis (Henriksen et al., 2011). The broilers response to stressful conditions, are both behavioural and physiological, the latter being modulated by pathways such as the Hypothalamic-Pituitary-Gonadal (HPG) axis, which is responsible for reproduction, and the Hypothalamic-Pituitary-Adrenal (HPA) axis, or the stress axis. The HPA axis mediates the stress response through glucocorticoid (GC) release, such as corticosterone (CORT). High GC levels have been shown to depress growth of skeletal muscle and lower performance of broilers in order to redirect energy expenditure to survival of the individual (Wasti et al., 2020).

The environmental conditions have a strong impact on stress and bird welfare; for example heat stress is a particular challenge as chickens are particularly sensitive to temperature-associated changes (Lara and Rostagno, 2013; Scanes, 2016). For this reason, an accurate

control of the environmental conditions is essential. Among the strategies, adopted to decrease the negative effect that heat stress can provoke, there is the use of specific feeding plans (Mohamed et al., 2019). The choice of feed, rich in protein or energy may modulate the chicken's intake of single components and optimise the heat load associated to the ingested nutrients metabolism. Also, the size and structure of feed can have a strong impact on the development of the gastro-intestinal tract (GIT) and favour a better digestion process, facilitate evaporate activity, modulate the heat load and led to beneficial effects. For this reason, supplementation of broilers diet with micronutrients has attracted industries and researcher's attention worldwide and nowadays there is a whole industry based on the development of new food strategies that can beneficially influence health and welfare (Wasti et al., 2020; Syafwan et al., 2011).

1.2.1 The broilers innate immune system

The innate immune system is highly complex and serves as the front line of the host's defence. It consists of barriers to infection, antimicrobial peptides and proteins, humoral and cellular components (Rojas-Villaraga et al., 2013). The innate immune response is based on recognition of conserved structures by macrophages, neutrophils and dendritic cells on pathogens, termed pathogen-associated molecular patterns (PAMPs), through a limited number of germ line-encoded pattern recognition receptors (PRRs), of which the family of Toll-like receptors (TLRs) is the most studied (Mogensen, 2009). TLRs recognize and respond to a variety of molecules, such as lipids (TLR1, 2, 4, 6), proteins (TLR5) and nucleic acids (TLR3, 7–9) (Nelson and Guyer, 2012). The activation of TLRs leads to increased activation of inflammatory pathways through cytokines release (Gil-Cardoso et al., 2016). The pro-inflammatory cytokines TNF- α , IL-1 β and IL-6 are produced from activated monocytes and neutrophils in response to inflammatory stimuli and they in turn initiate a complex network of secondary reactions (Ceciliani et al., 2002) including the release of acute phase proteins (APPs) (Saloma et al., 2012). Components that originate from gut microbiota, such as lipopolysaccharides (LPS), lipoteichoic acid, peptidoglycan, flagellin and bacterial DNA, can stimulate the innate immune response (Mogensen, 2009). These components can be found on the outer membrane of Gram-negative bacteria such as *Escherichia coli*, *Salmonella enterica*, *Neisseria meningitidis*, *Haemophilus influenzae*, *Bordetella pertussis*, *Pseudomonas aeruginosa*, *Helicobacter pylori*, *Klebsiella*

pneumoniae, *Legionella pneumophila* and *Chlamydia trachomatis* (Alexander and Rietschel, 2001).

1.2.2 *Escherichia coli* endotoxin (LPS challenge)

Researchers often use *Escherichia coli* (*E. coli*) lipopolysaccharide (LPS) extract in challenge experiments to evaluate an animal's ability to respond to an inflammatory stimulus (Alexander and Rietschel, 2001). This avoids the need to use infectious agents that require to be used in appropriate isolation facilities (Koppenol et al., 2014). LPS act as endotoxins (Gil-Cardoso et al., 2016) and the hosts' response depends on both the severity of infection and the LPS structure. In chickens, an LPS challenge typically induces fever, loss of appetite and increased heart rate (French et al., 2020). It has been demonstrated that a single dose of *E. coli* endotoxin (2 mg/kg body weight) activates the acute phase response (APR). The APR is quite complex and involves both systemic and local systems. An APR is initiated by infectious agents, inflammation, tissue injury, trauma or the introduction of immunogens such as LPS (O'Reilly and Eckersall, 2014). The induction of APR by these stimuli activates the production of pro-inflammatory mediators (cytokines and chemokines), which are generated by activation of macrophages, monocytes, platelets, fibroblasts, keratinocytes, endothelial cells and T-cells (Haudek et al., 2003). In mammals three major pro-inflammatory cytokines are largely responsible for the systemic effects of the APR: interleukins-1 and -6 (IL-1 and IL-6), and tumour necrosis factor (TNF- α) (Cray et al., 2009). The visible signs of the systemic effects include fever, anorexia (French et al., 2020), glucocorticoid release and the activation of the complement and clotting cascade (Ceciliani et al., 2002). The cytokines release also leads to decreased levels of serum zinc, iron and calcium (Luthman et al., 1991) and influence the profile of blood proteins, including the release of acute phase proteins (APPs) from the liver (Ceciliani et al., 2002) (Figure 1.3).

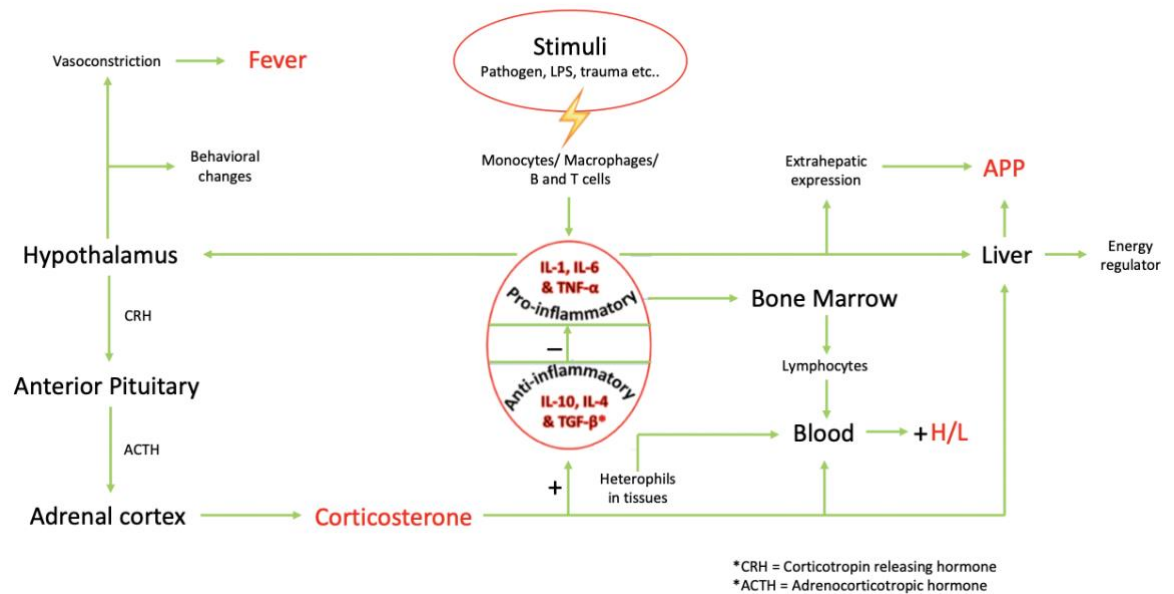

Figure 1.3 Acute phase response in chickens and associated outcomes

LPS, pathogens stimuli trigger various immune cells (monocytes, macrophages etc), at the site of infection, to produce pro and anti-inflammatory cytokines. Pro-inflammatory cytokines stimulate the liver to produce APP, and, in some instances, there is also an extrahepatic expression. Pro-inflammatory cytokines also stimulate the HPA axis which release corticosterone. Corticosterone up regulates the responses of anti-inflammatory agents and downregulates the pro-inflammatory cytokines. Part of this response impacts blood components by consequently increasing the Heterophil/Lymphocyte (H/L) ratio. Corticosterone also influences the energy metabolism by reducing the release of glucose from the liver (Cray et al., 2009; O'Reilly and Eckersall, 2014, Ceciliani et al., 2002).

APPs known to be modulated during the APR in chickens include Serum amyloid A (SAA), α 1-acid-glycoprotein (AGP), Ovotransferrin (OVT), Ceruloplasmin, Fibrinogen, Fibronectin, Hemopexin (Hpx), PIT54 (the chicken equivalent of haptoglobin) and Mannan binding lectin (O'Reilly and Eckersall, 2014). Recent proteomics investigations also revealed the role of other proteins, such as extracellular fatty acid binding protein (ex-FABP) (Horvatić et al., 2019) and MRP-126 (Matulova et al., 2013), as promising novel APPs. However, further research is needed to clarify their role and mechanism of action in broilers. Since APPs have different stimulation patterns, their profile can provide useful information on the host APR and several have now become established and useful biomarkers of overall broiler health and welfare (Ceciliani et al., 2002).

1.3 Antibiotics as growth promoters and anti-microbial resistance (AMR)

One of the downsides of the intensification of the poultry industry is that when large numbers of birds are kept in close proximity, disease can quickly spread throughout the flock and cause serious economic losses (Mennerat et al., 2010). Environmental conditions can also

influence the health of chickens if the management is not optimal. Prevention and control of poultry diseases has led during recent decades, to a substantial increase in the prophylactic use of antibiotics in poultry diets. In 1940, the growth promoter effect of antibiotics was discovered (Moore et al., 1946; Mehdi et al., 2018). The mechanism of action of antibiotics as growth promoters was found related to the interaction of antibiotics with the intestinal microbial population (Dibner and Richards, 2005). In 1999, the European Federation of Animal Health reported that in EU farm animals consumed 4.7 million kg of antibiotics in their feed (~35% of all antibiotics administered in the EU). The Union of Concerned Scientists estimated that 11.4 million kg of antibiotics were used in medicated animal feeds in the US alone each year (Landers et al., 2012). However, anytime antibiotics are used, they can cause side effects and lead to antibiotic resistance (Landers et al., 2012). Antimicrobial resistance is defined by the World health organization (WHO) as “the ability of a microorganism (like bacteria, viruses, and some parasites) to stop an antimicrobial (such as antibiotics, antivirals and antimalarials) from working against it. As a result, standard treatments become ineffective, infections persist and may spread to others”. The use of antibiotics in food animals selects for bacteria that are resistant to antibiotics used in humans, and concerns were that these might spread via farm workers or in the food to humans and cause problems to their health (Vanderhaeghen and Dewulf, 2017).

Such concerns about the development of antimicrobial resistance and transference of antibiotic resistance genes from animal to human microbiota, led to withdraw approval for antibiotics as growth promoters in EU the January 1, 2006 although treatment for disease is still permitted (Mehdi et al., 2018). In fact, in the UK progress over the last decade in this respect has been remarkable. According to a recent report, in the seven years, from 2012 to 2019, the British poultry council (BPC) Antibiotic Stewardship has helped achieve a 76% reduction in the total use of antibiotics and a 97.3% reduction in the use of critically important antibiotics (<https://britishpoultry.org.uk/bpc-antibiotics-report-2020/>). In part this has been due to improvements in management but also by finding suitable alternatives.

1.4 Alternatives to antibiotic growth promoters in poultry feed

The ban in use of antibiotics as growth promoters in poultry feed and the move to limit their use clinically has led to losses in productivity coupled with an increase in the incidence of bacterial diseases such as necrotic enteritis (NE) which affects the gut of broiler chickens

(Jia et al., 2009; Huang et al., 2018b). In addition to increased mortality and the increased risk of the disease spreading within a flock there is also a risk to human food safety through consumption of contaminated meat or derived products (Yegani and Korver, 2008). For these reasons, a lot of research has been carried out to look for natural supplements that when added to poultry diets confer similar beneficial effects to antimicrobial growth promoters (Mehdi et al., 2018). Various alternatives have been already widely explored with varying results. The most popular are probiotics, prebiotics, enzymes, organic acids, immunostimulants, bacteriocins, bacteriophages, phytogetic or novel plant feed additives, phytoncides, nanoparticles and essential oils. These alternatives have been extensively reviewed by Mehdi et al. (2018) but as the focus of this thesis was to investigate two novel plant extracts in broiler diets, further details on novel plant extracts are given below.

1.4.1 Novel plant extracts

During the last few years, a range of nutraceuticals have attracted the attention of the research community for their promising potential antimicrobial compounds. Nutraceuticals are defined as commercial additives obtained from natural products that can be used as an alternative feed supplement for the improvement of animal welfare. This group includes enzymes, synbiotics, phytobiotics, organic acids and polyunsaturated fatty acids. Possibly the most interesting of these are novel plant extracts that may contain several of these entities (Alagawany et al., 2021). Novel plant extracts are used in many applications, including raw and processed food preservation, pharmaceuticals, alternative medicines, natural therapies and animal feed. The identification and standardization of the beneficial chemical and/or biological compounds in plant extracts nevertheless is a major challenge for animal industries (Savoia, 2012). Among the variety of novel plant extracts available, citrus and cucumber were chosen to be investigated in this thesis. This decision was made on the basis of: the existing evidence of beneficial (immunomodulatory) effects of some of their bioactive compounds, the availability and cost of purifying suitable extracts for use in poultry diets, and importantly promising commercially sensitive data obtained from field trials already conducted by our company partner in this project, “Nuscience” who is based in Belgium (Dr Geert Bruggeman and Dr David Hermans - NuScience, Belgium – personal communication October 2018). It was they who supplied the experimental novel plant extracts.

1.4.1.1 Citrus extracts

Finding an alternative to the prophylactic use of antimicrobial growth promoters that reduces the risk of diseases, improves animal growth and advantages farms economically would benefit multiple sectors of society. Citrus extracts has already been demonstrated to be involved in numerous biological functions, including anti-bacterial, anti-oxidant (Ndayishimiye et al., 2018; Smeriglio et al., 2019), anti-inflammatory (Goliomytis et al., 2019) and anti-cancer (Kim et al., 2016). The strong antioxidant and anti-inflammatory properties are valuable in protecting animals from diseases and improving their health (Goliomytis et al., 2019). Citrus plants which include fruits such as orange, mandarin, lime, lemon, sour orange and grapefruit are also known to be a beneficial source of nutrients for humans (Rafiq et al., 2018). Many citrus purified bioactive compounds have shown to improve the immune functions and anti-oxidant capacity of plasma and meat in sheep (Simitzis et al., 2019) and piglets (Yiyan Cui et al., 2020). Animal experiments have shown that orange peel extracts improves the immune response and disease resistance of broilers without any effects on their growth performance (Pourhossein et al., 2015). This is important for poultry industries that are searching for low-cost nutritional alternatives that don't negatively influence the growth of broilers. Many bioactive compounds in citrus have been explored in detail to clarify their possible role in broilers health.

The citrus peel, seeds, and pulps generally discarded as waste represent a rich source of phenolic compounds and dietary fibre. Citrus extracts derived from these products is particularly rich in pectin (a source of soluble dietary fibre), polyphenols (including flavonoids), carotenoids, and essential oils (including Limonene). There are two main types of pectin: high methoxyl (HM) which is the most common type and low methoxyl (LM) (Rafiq et al., 2018). Beneficial effects of dietary fibres are mainly attributed to their fermentation products which produce anti-inflammatory short-chain fatty acids (SCFAs) such as butyrate, propionate and acetate (Sahasrabudhe et al., 2018). For instance, pectin are not directly digested by enzymes of the gastrointestinal tract, but they are fermented by bacteria resulting in the production of SCFAs (Mao et al., 2019). Although pectin occurs in a majority of plant, it is most abundant in citrus fruits and their chemical structure varies by fruit species and its different developmental stages (Ridley et al., 2001). Dietary supplemented with 20% apple pectin was found to decrease the incidence of azoxymethane-induced colon tumors in mice, and reduced intermediates of the inflammatory pathway such as prostaglandin E2 (PGE2) levels in the distal colonic mucosa and blood of the portal vein. This study indicated that the ability of pectin of reducing PGE2 is dose-dependent (Tazawa

et al., 1999). The *in vitro* modification of citrus pectin to modified citrus pectin (MCP) by changing the pH has been demonstrated to have anti-inflammatory and antitumoral properties (Smith-Barbaro et al., 1981). A recent *in vitro* investigation have also demonstrated the anti-inflammatory activity of citrus pectin on chicken monocytes' immune response (Ávila et al., 2021). Pectin might also bind with TLR2 and prevent proinflammatory responses (Sahasrabudhe et al., 2018). A MCP, such as DE90 pectin (90% esterified pectin), was found to bind LPS, and it might result in the decreased binding of LPS to its receptor (Chen et al., 2006).

Polyphenols, which include flavonoids, are demonstrated to produce positive effects on the immune system, small intestinal morphology, growth performance and blood circulating metabolites of broilers (Prihambodo et al., 2021). Polyphenols show anti-inflammatory properties through the inhibition of the action of pro-inflammatory enzymes, modulation of cytokines, inhibition of pro inflammatory cell adhesion molecules and/or scavenging reactive oxygen species (ROS) (Agatemor et al., 2015). Flavonoids are a class of phytochemicals with anti-oxidative and anti-inflammatory properties (Panche et al., 2016). Citrus flavonoids have already been demonstrated to be the most biologically active compounds on Earth (Pantsulaia et al., 2014). Flavonoids exert an antibacterial activity by inhibiting a wide range of pathogens that colonise the digestive tract and interfere with nutrient absorption (Iqbal et al., 2020). A lower pathogen community increases the growth performance and regeneration of intestinal villi which consequently intensifies the nutrient absorption. Flavonoids may stimulate the secretion of mucus by resulting in better villus protection and an increase in probiotic bacteria abundances. In a similar way, lemon peel extracts supplementation might also modify some blood components and the proximal intestinal morphology of broiler chickens (Ishisono et al., 2017). Quercetin, the major representative of flavonoid belonging to the class of flavonols, has been demonstrated to improve oxidative status of broiler meat when added to broiler diet and can be detected in plasma and several tissues (Hager-Theodorides et al., 2014). Quercetin supplementation has been found to improve calcium, phosphorus metabolism and tibia development in broilers (Wang et al., 2022). Hesperidin, another representative of flavonoid, was found to prevent intestinal inflammation in mice (Lee et al., 2011).

Carotenoids are natural colouring agents that exhibit antioxidant, anti-inflammatory and antimicrobial properties (Mavrommatis et al., 2022). Carotenoids have been demonstrated

to modulate the APR of broilers subjected to *E.coli* LPS challenge and to increase villus length for a better nutrients absorption (Csernus et al., 2020).

Limonene (LIM), is the major component in the oil of citrus fruit peels and it has also been demonstrated to be involved in the modulation of the immune response in broilers (Hafeez et al., 2016). Its mechanism of action in broilers is still under investigation but in humans Limonene has been reported to have a role in proinflammatory pathways; Limonene can effectively inhibit LPS-induced nitric oxide and PGE2 production in macrophages and decreases interleukin-1 α (IL-1 α) levels in undifferentiated keratinocytes (Bevilacqua et al., 2010).

1.4.1.2 Cucumber extracts

Another novel plant extracts which is attracting the attention of researchers is cucumber (*Cucumis sativus*). Cucumber is a fruit that belongs to the Cucurbitaceae family (Huang et al., 2009), and it is a source of beneficial bioactive compounds. For example, bioactive phenolic compounds are present in the methanol and water extracts of fresh cucumber (Abu-Reidah et al., 2012). Their leaves also contain flavonoids and phytochemicals that are linked in the defence mechanism of the plant (McNally et al., 2003). The active principles in these vegetal extracts are principally water soluble or lipophilic antioxidant molecules. Cucumber also contains different amounts of Vitamins and β -carotene and polyphenols (Vouldoukis et al., 2004). Indeed, in humans and livestock researches, cucumber extracts exhibits anticancer (Gao et al., 2014), antioxidant (Nema et al., 2011), antimicrobial (Tang et al., 2010) and analgesic (Kumar et al., 2010) properties (Agatemor et al., 2015). Seeds of Cucumber have been also found to possess a potential wide spectrum of antimicrobial properties (Sood et al., 2012). Phytochemical screening of cucumber seeds found the presence of flavonoid, tannin, saponin, and steroid. These compounds were again found associated to antibacterial and anti-inflammatory activities in rats (Subramanyan, 2013). Cucumber has been used in folk medicine as a treatment for inflammatory related disease for centuries (Mukherjee et al., 2013). The anti-inflammatory properties of cucumber have gained popularity and these investigations suggest that the whole fruit is involved in reducing the inflammatory response. Cucumber extracts has been demonstrated to attenuate the damaging effect of LPS in endothelial cells by decreasing the expression of TLR4 induced by LPS and, consequently, inhibiting pro inflammatory cytokines and increasing anti-inflammatory cytokines (Bernardini et al., 2018). This information suggests that Cucumber extracts could be a very

interesting candidate for limiting inflammatory pathologies in which TLR plays a crucial modulatory role. In broiler chickens, *Pediococcus pentosaceus* FBB61, a bacterium isolated from cucumber fermentation, has been shown to be effective against Clostridia one of which is the cause of NE (Grilli et al., 2006). This suggests that feeding cucumber extracts as supplement may influence the gut microbial population. However, no other information is available in the literature to support this hypothesis.

Indeed, research for this thesis has failed to find any published work on feeding cucumber extracts to broilers, apart from those emanating from our Manna Research Project (<https://www.mariecuriealumni.eu/news/what-happens-when-you-supplement-diet-broiler-chickens-extracts-cucumber-and-citrus>) and our commercial partner, Nuscience. They have been running feeding trials with this compound (results protected by commercial confidentiality) in both piglets and poultry based on the existing evidence of beneficial activities that bioactive compounds can exert in other animal species and *in vitro*. They report improved zootechnical performance and immunology, although the results for poultry were more variable when compared to piglets (Dr Geert Bruggeman and Dr David Hermans - NuScience, Belgium – personal communication October 2018).

1.5 Useful indicators or biomarkers of health and disease that can be used in dietary investigations

Dietary supplements, used by poultry producers to enhance bird growth and reduce risks of infections, often rely solely on production data (feed and weigh type experiments) without investigate the functional relationship or mechanism of action between the bioactive compounds. Therefore, in this section various methodologies that would help to build this evidence base are discussed.

Only by having a fuller picture of the mechanisms and interactions between the host and molecules provided through the supplementation can one confidently develop new dietary plans that enhance bird growth, maximize host feed utilization and protect birds from diseases caused by pathogenic bacteria (Zheng et al., 2016; Ruiz et al., 2008; Jia et al., 2009). LPS can activate the immune response of broilers and modulate microbial populations, proteins, and metabolite profiles. Similarly, bioactive compounds in dietary treatments may be responsible for positive effects on certain microbes, proteins and metabolites under normal physiological conditions and so can help to reduce inflammation during LPS

challenge. In this section keyways of assessing the benefits of dietary intervention are discussed.

Gut viscosity and Histo- Morphometric measurements

The gold standard most often used to assess the effect of a dietary intervention is to measure the viscosity of the gut contents and histo-morphologically examine segments of the small intestine and measure villus length, crypt depth and the relative thickness of other tissue layers (Verdal et al., 2010) (see – 2.3.4 Gut morphometric measurements - for more details).

The intestinal Microbiota

The intestinal microbiota of humans and animals is defined as the community of microbial organisms that inhabits a defined environment (Jandhyala, 2015) (see – 1.7 Microbiota). The bacterial community that characterized the GIT of chickens is considered as an essential component which contributes to the wellbeing of animal host in a wide range of aspects, especially nutrition and gastro-intestinal disease resistance (Nakao et al., 2013). Bacterial microorganisms have a highly significant impact on the uptake and utilization of energy, and other nutrients, and on the response of poultry to antinutritional factors and feed additives (Torok et al., 2008). Specific bacteria, such as *Firmicutes* and *Lactobacillales* are used as intestinal biomarkers of health in broilers (Aruwa et al., 2021). Investigating the effect of dietary interactions on the GIT microbiota is therefore another useful tool in determining the value of any additives.

APPs as biomarkers of health and disease in poultry

As previously mentioned, the APR initiated during LPS challenge experiments provides a useful tool to investigate the effect of dietary interventions on the immune system of broiler chickens (see - 1.2.2 *Escherichia coli* endotoxin LPS challenge). In broilers a number of APPs are now established as useful biomarkers of the APR response (O'Reilly and Eckersall, 2014). Dietary components could result in a modulation of the APR response. This hypothesis is discussed more fully in section 1.4- Alternatives to antibiotic growth promoters in poultry feed.

Proteins and metabolites

In the last decade, the results obtained by the animal genome sequencing have contributed to the development of several techniques able to describe the variation in the expression level of genes, proteins, and metabolites. While genomic DNA remains constant during the lifespan of an animal, its expression varies and moreover the proteins and metabolites (gene products) also change their expression levels in a rapid and dynamic manner due to environmental and physiological factors. Nowadays, transcriptomics, proteomics and metabolomics are the main Omics technologies used to investigate, respectively, the expression of genes, proteins, and metabolites. All Omics are important to describe the complex phenotype of cells and organisms. The molecular basis of cellular phenotypes involves genes, mRNA, proteins, and metabolites. Depending on the aim of interest to explore, a specific Omics can be used (Debnath et al., 2005).

Defined circulating/tissue proteins and metabolites are proving to be good biomarkers that indicate the health state of broilers. When a disease occurs, imbalances in proteins or metabolites have been registered by few studies (Khovidhunkit et al., 2000; Rinttilä and Apajalahti, 2013). Most of the research carried out until now mainly focused on single proteins or metabolites but nowadays, the development of Omics technologies (see – 1.8 Omics technologies), allow their overall massive detection and represent a key strategy for novel health biomarkers identification (Barallobre-Barreiro et al., 2013; Aslam et al., 2017).

However it is considered that a single biomarker will not be sufficient to follow up all aspects of broilers' health but combinations of data from multiple approaches using microbiota and other Omic technologies investigations are necessary for the full study of dietary effects in broilers (Ducatelle et al., 2018).

1.6 Microbiota

Microbiota, the community of microbial organisms that inhabits a defined environment (Jandhyala, 2015), is very diverse and includes bacteria, fungi, protozoa, archaea and yeasts. The term microbiota is not synonymous of microbiome. The microbiome refers to the collection of genomes from all the microorganisms inhabiting a specific environment (Ursell et al., 2012). Microbiota is involved in the development of the immune system, nutrition, drug response of the host, the hosts susceptibility to infectious chronic diseases and can alter the behaviour in both humans and animals (Jandhyala, 2015). The homeostasis of the organism is maintained through the dynamic inter-relationship between the host and its

microbiota (Belkaid and Harrison, 2017). A lot of external factors can alter the homeostasis of individuals microbiota such as infections, environmental factors, exposure to antimicrobial growth promoters or changes in the dietary regimen (Hills et al., 2019). Microbiota composition and its potential use as a biomarker for health and reproduction is being investigated widely, but the validation remains a major challenge, so continued research in this field is required and this study adds to the knowledge base required for this definition (Ducatelle et al., 2018).

1.6.1 Methods of studying Microbiota

The bacterial community of the intestinal microbiota is the most extensively studied and at present is believed to be the most important and innovative biomarker of gut health. The evolution of this aspect of study is similar to that of other microbial ecosystems, moving from culture-based and microscopic observations to the use of culture-independent, molecular techniques (Costa and Weese, 2019). The small subunit ribosomal RNA gene (16S rRNA) is the most common target for characterising bacterial diversity in the intestinal microbiota in both humans and animals and it is considered a well-established method for studying the composition of the intestinal microbiota (Rosselli et al., 2016). This has essentially replaced other techniques such as single-strand conformation polymorphism (SSCP), denaturing gradient gel electrophoresis, restriction fragment length polymorphism (RFLP) and its variant terminal-RFLP (Blackwood et al., 2003). The development of next generation sequencing (NGS) and Illumina technologies has supported the rapid growth of 16S ribosomal RNA gene (16S rRNA) applications including the screening of complex microbial communities (Cao et al., 2017). The improvement of high-throughput sequencing led to more and more accurate sequencing analysis. However, Illumina sequencing methodology presents some limitations in terms of shortness of 16S rRNA bacteria regions which are sequenced and consequently the diversity of microbiota that can be determined at best at the genus level (Jovel et al., 2016). This problem has been overcome by the development of the nanopore long-read sequencer MinION™ able to sequence the entire gene from the extracted DNA to rich species level (Lu et al., 2016; Tyler et al., 2018).

This method has already been applied in animals for example to characterize the microbiota of dog skin (Cuscó et al., 2017) and buffalo milk (Catozzi et al., 2020). No studies are present in the literature on the use of MinION™ technology to sequence the whole gut genome of broilers. Due to lack of knowledge in the use of nanopore MinION™ to study the broilers

microbiota, its high raw error rate and the lower read accuracy compared to short reads sequencer, the 16S rRNA NGS based sequencing methodology was elected for this study. I note with interest I am not alone in this consideration (Cuccato et al., 2021).

1.6.1.1 16s rRNA gene sequencing

The sequencing of the 16S rRNA gene is the gold standard technique for characterising bacterial diversity and studying the microbiota composition (Rosselli et al., 2016). The 16S rRNA gene is approximately 1,500 bp long and contains conserved regions alternated by nine variable regions that serve as universal primer bindings sites for the amplifications of genes (Johnson et al., 2019) (Figure 1.5). This method provides phylogenetic classifications from phyla to genus in different microbial populations. The decision on the hypervariable regions to amplify is made according to the specific experimental objectives, design, and sample type.

In broilers, different regions of 16S rRNA have been used by researchers to study the effect of diets or treatments and to characterize their microbiota composition: Danzeisen et al. (2011) targeted the region V3, Adewole and Akinyemi, (2021) and Stamilla et al. (2021) targeted the V4 region while Vieira et al. (2020), Cuccato et al. (2021) Saeed et al. (2019) focused on targeting both regions V3-V4. The V3-V4 regions were found to provide higher resolution in microbial diversity and Operational taxonomic unit (OTU) classification compared to the other regions (Ong et al., 2013). These are therefore considered the best regions to use for microbiota investigations when there is not a specific bacterial target (Cuccato et al., 2021).

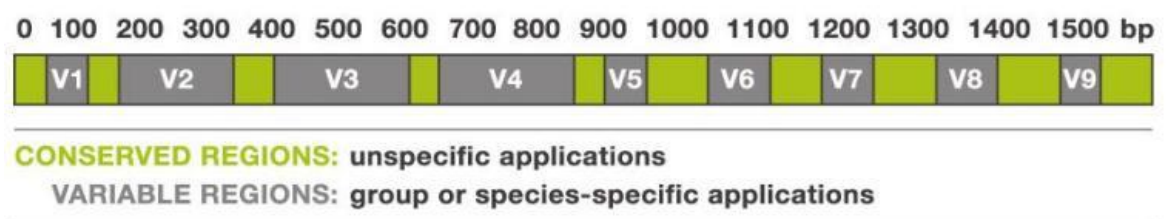

Figure 1.4 Bacterial 16S ribosomal RNA (rRNA) gene

The gene is approximately 1,500 bp long and contains nine “hypervariable regions” (V1 – V9) (grey) alternated by conserved regions (green).

1.6.2 Broilers gut microbiota

The digestive system of the broiler chicken is composed of the oesophagus, crop, proventriculus, gizzard, small intestines (duodenum, jejunum, and ileum), caeca, colon and

cloaca – the GIT (Jacob, 2013). These organs can be differentiated from each other both morphologically and functionally. The microorganisms present in these various regions have a highly significant impact on the uptake and utilization of energy metabolism and other nutrients and on the response of poultry to “antinutritional” factors, pre and post probiotic feed additives, and feed enzymes (Torok et al., 2008). Diet has a key role in the modulation of the microbial community as dietary compounds, which escape host digestion and absorption, and are used as the substrates for bacterial growth. Many indigestible dietary compounds can be fermented by intestinal bacteria, yielding SCFAs such as acetate, propionate, and butyrate which can then be used both as energy and a carbon source by the host and so may also help to regulate the gut microbiota (Mahmood and Guo, 2020). However, diets rich in indigestible non-starch polysaccharides, can lead to the proliferation of *Clostridium perfringens* type A which is responsible of necrotic enteritis in young chicks (Annett et al., 2002).

The host provides a permissive habitat and nutrients for the colonization and growth of these bacteria (Pan and Yu, 2014). Broilers also harbour highly diverse bacterial communities along the different regions of the GIT (Sergeant et al., 2014; Oakley et al., 2014). There are multiple factors that can influence the bacterial composition of the broiler’s microbiota: gut site, age, sex, diet and the use of antimicrobials but a recent review summarises that it is possible to predict some of these difference along the GIT (Feye et al., 2020). The major changes in spatial distribution of microbial composition along the chicken GIT at the phylum level were summarised by Choi et al. (2014). According to these authors *Firmicutes* are the dominant phylum in duodenum, jejunum, ileum and colon, while *Bacteroidetes* is the dominant phylum in caeca. At the genus level the major microbial genera across all gut sections are *Lactobacillus*, *Enterococcus*, *Bacteroides*, and *Corynebacterium* (Xiao et al., 2017). At a more regional level the genus *Lactobacilli* are found to be the dominant bacteria in the crop (Gong et al., 2007). In the gizzard, which has a minor bacterial fermentation activity, bacteria from sources such as *Lactobacillus*, *Enterococcus*, lactose-negative *Enterobacteria* and coliform bacteria are the major genus constituents (Gong et al., 2007). The small intestine, represented by the duodenum, jejunum and ileum, is primarily responsible for nutrient digestion and absorption (Gong et al., 2007; Rowland et al., 2018). The duodenum has the lowest bacterial density, mainly consisting of *Clostridiaceae* family, and various *Streptococci*, *Enterobacteria*, and *Lactobacilli* genus (Waite and Taylor, 2015). The jejunum is generally mostly dominated by the *Lactobacillales* order and a lower abundance of *Clostridiales*. This site, together with the upper tract of the intestine, is the one

mostly dominated by different genus (mainly *Lactobacillus* and *Enterococcus*) of the *Lactobacillaceae* family (Gong et al., 2007; Stamilla et al., 2021). The Ileum is the most studied region of the small intestine: The ileum harbours a significantly more diverse population of bacteria than the duodenum and jejunum (Haghighi et al., 2006). *Lactobacillus* constitutes the major group followed by *Clostridiaceae* family, *Streptococcus* and *Enterococcus* genus (Lu et al., 2003). Much work has already been performed to characterize the broilers ileal microbiota and its modulation by diets (Gong et al., 2002; Hoeven-Hangoor et al., 2013; Richards-Rios et al., 2020); However, the Ileal microbiota can be influenced by the caeca, due to their closer anatomical position (Yan et al., 2019). Hence since there are few studies on the microbiota of the jejunum it makes it an interesting candidate for further investigation. In summary *Lactobacillus* was the predominant genus found in the duodenum, jejunum, and ileum (>35%), interesting it was rarely present in caeca (Xiao et al., 2017). The caeca have the greatest taxonomic diversity and so tend to be the primary choice for microbiota investigations concerned with dietary modulation (e.g supplementation with novel plant extracts). This is because many of the bacteria found here are involved in the fermentation process, which leads to the production of SCFAs that constitute the 10% of a chicken's metabolizable energy (Józefiak et al., 2004).

Large variations in microbial composition have been observed when broilers are sampled at different ages (Choi et al., 2014; Jurburg et al., 2019). Kumar et al. (2018) found that *Firmicutes* were the most abundant phylum in both the caeca and the ileum at all ages from day 0 to day 42, while according to Oakley and Kogut, (2016) ceecal bacterial composition quickly shifts with age from *Proteobacteria*, *Bacteroides* and *Firmicutes*, to almost entirely *Firmicutes* by 3 weeks age. Similarly, the study of Lu et al. (2003) demonstrated that the microbiota complexity increases with the bird's age: birds at 3 and 7d of age, at 14 to 28d of age, and at 49d of age were all shown to exhibit different microbial communities. Thus, the consensus seems to be that as the bird advances in age the GIT microbiota, appear to move to a more stable position in terms of the bacterial taxa (Crhanova et al., 2011) with its peak diversity at day 14 in the small intestine and 28 in the large intestine (Huang et al., 2018b). The study of Amit-Romach et al. (2004) also affirmed that the microbiota of birds in the small intestine is well established within 2 weeks.

From the literature it can be reasonably hypothesized that the bioactive compounds found in citrus and cucumber will modulate selective bacterial strains in the GIT of broiler chickens. Polyphenols for example are recognised to possess prebiotic properties which support the growth of selective bacteria by acting as a source of nutrient supply (Marín et al., 2015). In

particular flavonoids and carotenoids show antimicrobial potential against pathogen bacteria (Tolnai et al., 2021). Alçiçek, et al. (2004) reported that blends of essential oils can increase the number of lactic acids, such as *Lactobacilli*, in broilers; Essential oils can also inhibit pathogenic bacteria in the small intestine of broilers (Tiihonen et al., 2010). Vitamins have also been shown to be associated with the growth of beneficial bacteria (Yang et al., 2020). Finally, as already mentioned even the more indigestible portion plays a part. These considerations justify investigating whether of citrus and cucumber extracts modulate the GIT microbiota of broiler chickens.

In conclusion, trials designed to assess the effect of dietary supplementation with these novel additives using microbiota seem well on the GIT microbiota must take bird age into account and should be standardised to allow comparisons with the existing literature. Unfortunately, this important fact is often overlooked.

1.7 Acute phase proteins in chickens (APPs)

Many APPs have been demonstrated to be established biomarkers of toxicity in chickens (O'Reilly and Eckersall, 2014) but in the context of the thesis the focus will be first on Serum amyloid A (SAA) and Alpha acid glycoprotein (AGP). This choice was made based on the availability of species specific commercial ELISA assays for SAA and AGP detection and previous investigations which demonstrated the role of SAA and AGP as the most important APPs in chickens (O'Reilly, 2016). Recently, a novel observation of the proteomic investigation carried out on broilers (Horvatić et al., 2019) found that plasma levels of extracellular fatty acid binding protein (ex-FABP) precursors and hemopexin (Hpx) were also increased in response to LPS and may be considered potential biomarkers of toxicity. Another APP of growing interest in broiler chickens is MRP-126 which has shown an increase in its abundance after bacterial infection (Dr. Chris Chadwick - Life Diagnostics – personal communication September 2019). Further academic-industrial collaboration with Life Diagnostics has led to antibody production to chicken immunoassays that can detect these proteins in plasma. In this thesis SAA, AGP ex-FABP, Hpx and MRP-126 are used to investigate the hypothesis that the bioactive compounds in broiler diets supplemented with either citrus or cucumber modulate the APR of broiler chickens following an LPS challenge.

1.7.1 Measuring APPs in chickens

APPs are generally produced in the liver and then secreted into the blood (O'Reilly and Eckersall, 2014). APPs can be measured in both plasma or serum but in chickens, plasma is more often used because it is easier to collect (Hrubec et al., 2002). Blood samples can be collected from chickens using different anticoagulants such as EDTA or heparin and then be centrifuged to allow cell separation. However, heparin is reported as the preferable anticoagulant for avian species (Hrubec et al., 2002).

APPs can be classified as minor, moderate or major according to the magnitude and timing/duration of increase during APR. Major APPs increase 10 – 1000 fold, moderate APPs increase 4 - 10 fold and minor APPs increase 2 – 3 fold. Major APPs tend to increase within the first 48h after a triggering event (e.g LPS challenge) and decline rapidly. Moderate and minor proteins tend to increase more slowly and show a more prolonged duration (Cray et al., 2009; Eckersall and Bell, 2010)

Different immunoassays can be used for the detection of APPs but when antibodies which react in chickens are available, ELISA assay is used as the preferable methodology. ELISA assays use affinity purified chickens APPs antibodies for solid phase immobilization and horseradish peroxidase (HRP) conjugated chicken APPs antibodies for detection. The availability of well optimised AGP and SAA ELISA kits, which utilises chicken specific antibody, makes these two among the most widely measured APPs in chickens.

However, the immunoassays for chicken ex-FABP, Hpx and MRP-126 are at an early stage of development so further investigation on these novel APPs would be extremely useful for the protocol optimization in broilers and could help in the discovery of novel biomarkers. As well as the conventional ELISA system other immunoassay formats such as the Spatial Proximity Analyte Reagent Capture Luminescence (SPARCL™) have been developed to increase the precision and speed of the assays. SPARCL™ assays use two specific antibodies; one conjugated to HRP, the other to acridan which is a chemiluminescent substrate.

In this thesis, SAA, AGP, ex-FABP and Hpx will be explored using ELISA assays while SPARCL™ assay will be used for MRP-126 detection.

1.7.2 Serum amyloid A (SAA)

SAA is the major APP in chickens which circulates in blood and dramatically increases its expression by more than 100-fold, in response to inflammation (Matulova et al., 2013); this protein plays an essential role in the broilers immune defence; SAA can inhibit pyrexia and the activation of pro-inflammatory pathways during the APR (Uhlir and Whitehead, 1999). It has also been demonstrated to influence the transport and metabolism of lipoprotein during APR to allow the permeability of cholesterol into damaged tissues with the aim to repair and to clear lipid debris (Landman et al., 1998). SAA is particularly sensitive to LPS challenge and different studies (Horvatić et al., 2019; O'Reilly and Eckersall, 2014; Upragarin et al., 2005) reported that the levels significantly increase in birds subjected to experimental infection (e.g *E. coli* or *Staphylococcus aureus*) within the first T12h post challenge.

1.7.3 Alpha acid glycoprotein (AGP)

AGP is a sialo-glycoprotein synthesized and secreted by the liver; local AGP can contribute to maintain the homeostasis by reducing the tissue damages that occur during inflammation in extrahepatic cells. Systemic AGP has two main physiological functions: immunomodulation and drug binding. AGP is able to neutralize the toxicity of bacterial LPS by binding to protein (Murata et al., 2004). This APP can be measured in serum using a commercially available ELISA assay (O'Reilly, 2016).

In livestock, AGP is used as a biomarker of inflammation in a variety of species including pigs (Itoh et al., 1993), ruminants (Tothova et al., 2014), and dogs, (Yuki et al., 2010). AGP is a useful established biomarker in broilers which increases ~5-fold and peak 24h during the APR in plasma and serum (Takimoto et al., 2008; O'Reilly, 2016); In chickens AGP has been classified as a moderate APP (O'Reilly and Eckersall, 2014). It has been demonstrated that the level of AGP significantly increased post *E. coli* (Nakamura et al., 1998) or *Salmonella Typhimurium* (Kevyn et al., 2001) infections and it has also been shown to change in LPS challenge experiments (Takashi et al., 1995; Horvatić et al., 2019).

1.7.4 Hemopexin (Hpx)

Hemopexin (Hpx) is a haem binding protein and APP in chickens (Kevyn et al., 2001). Its main role is to sequester and transport haem; it is a multifunctional protein involved in iron

homeostasis, antioxidant production and signalling pathways to enhance cell survival and gene expression (Grieninger et al., 1986). Different studies have been carried out in chickens to study how this APP is modulated during APR; the study of Barnes et al. (2002), using *E. coli* LPS to induce an APR, found Hpx increased 2.6-fold. Similarly, Kevyn et al. (2001) used *Salmonella Typhimurium* LPS and complete Freund's adjuvant to challenge chickens and found an increasing concentration of Hpx 24h post infection. Garcia et al. (2009) found Hpx to increase in response to intra crop *Salmonella Gallinarum* as well, with serum concentration starting to decrease 7d post infection.

However, the lack of commercially available kits able target Hpx in chickens limited information available on this APP. For this reason, its behaviour and mechanism of action during APR requires further investigation.

1.7.5 Ex-fatty acid binding protein (Ex-FABP)

Ex-FABP is a lipocalin protein reported to increase in response to inflammation (e.g LPS) and tissue degeneration in chickens (Descalzi et al., 2002). This protein is physiologically expressed during endochondral bone formation, and other cell differentiation pathways and may be required to stimulate cell proliferation, tissue repair and defence of the host (Cermelli et al., 2000). Ex-FABP has been shown to influence cartilage, muscle cell differentiation and heart development (Gentili et al., 2005). The study of Simon et al. (2019) found that Ex-FABP expression increased in chickens with altered intestinal morphology. However, this protein has not been validated yet in broilers but recent evidence from a proteomic investigation suggest it could have a possible role as a biomarker of the APR (Horvatić et al., 2019). The lack of commercially available diagnostic tool that can target Ex-FABP in chickens explained the limited information on this APP. For this reason, Ex-FABP was also considered a good candidate for further investigation.

1.7.6 MRP-126

MRP-126 belongs to the calgranulin protein family and has a similar behaviour to calgranulins which are produced by different tissues and then secreted into the blood (Bozzi and Nolan, 2020). The study of Matulova et al. (2013) reported that MRP-126 concentrations increase following *Salmonella* infection and suggest its role in modulating the growth of certain bacteria (Bozzi and Nolan, 2020). Similarly the study of Rychlik et al. (2014) found the level of MRP-126 increased in leukocytes lining the caeca level 4d after bacterial

infection. MRP-126 represents a protein of growing interest in broiler chickens but further investigation is required to classify it as a useful biomarker (Dr. Chris Chadwick- Life Diagnostics – personal communication March 2022). Also, for this APP, the difficulty in finding commercially available tool to target the protein in broilers is the cause of a lack of information. In this thesis, MRP-126 will be measured in plasma using the SPARCL™ assay.

1.8 Proteomics

Proteomics is the large scale study of the total proteome (Graves and Haystead, 2002). The term “proteomics” was coined for the first time in 1995 and then defined as “the large-scale characterization of the entire protein complement of a cell line, tissue, or organism” (Wilkins et al., 1996). Proteomics includes many different areas of study such as protein-protein interaction studies, protein modifications, protein function, and protein localization studies. The objective of proteomics is not only to study all the proteins in a cell but also to investigate the three-dimensional map of the cell giving information about the location of the protein and their protein interaction networks by proteome peptide scanning their network.

1.8.1 Methods of studying proteomics

Different technologies can be used for the investigation of proteins/peptides. For validation or analysis of selective proteins, enzyme-linked immunosorbent assay (ELISA) and western blotting (WB) can be used. These techniques are not quantitative and can be used for specific proteins (Porsch-Özcürümez et al., 2004). Techniques such as gel-based approaches Sodium dodecyl sulfate-polyacrylamide gel electrophoresis (SDS-PAGE), and the more advanced two-dimensional gel electrophoresis (2-DE) can be used for separation of complex protein samples (Garca-Descalzo et al., 2012) and were the mainstay of proteomics in its initial period. More recently, mass spectrometry (MS) have been developed for high-throughput and rapid expression analysis (Yates, 2011) and have become integral to the expansion of the application of proteomics to much biological research including investigations in animal science (Bilić et al., 2018).

MS can measure the mass-to-charge ratio (m/z) of ions based on their motion or magnetic field (Westermeier et al., 2008). The standard procedure for shotgun proteomics, includes

trypsin digestion where peptide bonds at the carboxyl-terminal of lysine and arginine amino acid residues are cleaved. Then the peptide masses are determined using the MS and a unique peptide mass fingerprint created which make possible to infer the amino acid composition of the peptides (Lilley and Friedman, 2004). Nowadays, two main MS platforms, which differ in the mechanism through which ions are generated, can be used: matrix-assisted laser desorption/ionization (MALDI) and electrospray ionization (ESI) (Ceciliani et al., 2014). To characterise the proteome, the number of proteins that MS is asked to analyze must be temporally limited to simplify the complex mixtures and this can be done by applying either electrophoretic or chromatographic fractionation (or both). If MS is elected as the preferable method, chromatography techniques offer high-throughput analyses of the proteome (Abdallah et al., 2012). A standard procedure would include the trypsinisation of proteins to generate peptides and then the fractionation by high performance liquid chromatography (LC) before the analysis by the ESI-MS that is directly plumbed with the chromatography eluate (LC-MS). The MS is capable of recording the mass of analytes and isolate and fragment peptide ions (MS/MS or tandem MS) to gain information about the structure. The resulting data are fed to a search engine which can generate *in silico* MS data that are compared to a specified genome sequence database to identify statistically significant matches with the MS data generated by the experiment (Ceciliani et al., 2014). Although this procedure can result in the identification of thousands of proteins, no single method can resolve all the proteins in a proteome. Quantitation in MS is based on stable isotope or chemical labels that are introduced in a previous step, by labelling the intact proteins or peptides (Almeida et al., 2015).

1.8.2 Studying the Broilers Proteome

In chickens, proteomics has been used to explore the development and function of organs and biological systems to the interactions of pathological agents and the altered status that they induce in their hosts (Kumar and Mann, 2009). The use of proteomics to investigate disease and identify biomarkers in the field of animal health and in particular in broilers has grown popularity in the last 20 years. Proteomics has been applied for the investigation of different poultry diseases: in chickens affected by Marek's disease infection, the splenic proteome revealed a number of differentially expressed proteins such as antioxidants, and proteins involved in the formation of cytoskeleton, protein degradation, antigen presentation, signal transduction and cell proliferation (Thanthrige-Don et al., 2010). In chickens affected

by the Newcastle disease virus infection, the peripheral blood mononuclear cell proteome revealed proteins differentially expressed associated to the disease. These proteins were found to be involved in the biosynthesis, cytoskeleton organization, metabolism, stress responses, and signal transduction (Deng et al., 2014). Since intestinal health is of primary importance in terms of growth rate in broilers it is no surprise that there have been a number of studies of the intestinal proteome both in health and disease. Metabolic diseases have also been investigated by proteomic studies of the hepatic proteome of broilers affected by ascites syndrome (Wang et al., 2012). This has been enlarged to the proteomics of other organs such as the liver in other diseases such as Broiler Ascites Syndrome a disease where the high metabolic rate of the broiler is a major factor contributing to their susceptibility (Wang et al., 2012). Similarly, the effects of heat stress have also been investigated on the hepatic proteome of broilers (Tang et al., 2015). Proteomic methods are also used to study the poultry meat and egg quality investigating using muscle samples (Doherty et al., 2004).

Thus proteomics studies can be applied to different type of samples based on the experimental objective. In our study, liver and muscle samples were considered the best candidates for studying the proteome of broilers fed with CTS and CMB diet during LPS challenge conditions. In broilers, liver and muscle proteomics have been demonstrated to have a physiological relevance associated with specific diseases, metabolic conditions, and production traits (Doherty et al., 2004; Hassan et al., 2018). The liver is one of the main organs involved in many important metabolic processes (Zaefarian et al., 2019; Hassan et al., 2018). The study of Hassan et al. (2018) demonstrated that broiler chickens have a different liver proteome compared to indigenous chickens. Most of the proteins modulated by genotype were found to be associated with several metabolic pathways in mitochondria and cytosol liver tissues; in particular a family of heat shock protein 90 (Hsp90) was found to be lower in abundance in the commercial broiler genotype compared to the indigenous chickens suggesting that the commercial genotype may be more susceptible to heat stress. Structural proteins such as actin, were also found to be lower in abundance at the liver level of broilers compared to indigenous chickens (Hassan et al., 2018). Moreover, the liver produces the majority of proteins which are released into the plasma. Plasma proteomics has been already recently investigated by our associated research group at the University of Zagreb, Croatia using broilers challenged with *E. coli* LPS (Horvatić et al., 2019). This study highlighted the influence of LPS in modulating the proteome of broilers and specifically validated different APPs (SAA, AGP, OVT) raised in the first 24h post LPS challenge. Similarly, the study of Packialakshmi et al. (2016) demonstrated that plasma levels of

proteins involved in the immunomodulation, cytokine changes, and defence mechanisms were differentially expressed in broilers challenged with LPS. For this reason, I wished to integrate our results from a study of the broilers' liver proteome under LPS challenge with the existing data on plasma.

The selection of broilers for meat production has led to the generation of inbred strains characterised by accelerated growth, which is particularly reflected in the enhanced growth of the pectoralis (breast) muscle (Griffin and Goddard, 1994; Emmerson, 1997). The pectoralis muscle of chickens is constituted almost exclusively by white fast twitch fibres, and this makes the muscle a relatively simple tissue to assess protein expression and dynamics. The analysis of proteins that could influence the muscle growth provides a good tool for analysis of the processes of muscle accretion (Tesseraud, et al., 2000). The study of Doherty et al. (2004) demonstrated that the breast muscle of broilers offers an excellent system for proteomics investigation: structural proteins, such as tubulin and myosin, are representative of the skeletal muscle and can be used as indicator of muscle growth. In livestock, LPS is expected to induce muscle wasting (Holecek, 2012) but relatively little information is available for broilers so it would be of interest to further clarify the role of both LPS and dietary treatments during LPS challenge on the modulation of the muscle proteome.

Bird age and sex can also influence the proteome of broilers. The intestinal proteome of broilers of 12 to 22d of age for example has been demonstrated to show developmental changes, indicating a close link between age related changes in the intestinal microbiome and protein expression (O'Reilly et al. 2016). Very limited information is available in the literature on dietary proteome modulation in broilers. However, if some bioactive compounds can modulate the microbiota and immune response of broilers (see 1.4 - Alternatives to antibiotic growth promoters in poultry feed), the expression of proteins involved in this might be influenced.

In this investigation it was hypothesized that the active compounds in the citrus or cucumber dietary extracts modulate the liver and muscle proteomes of broilers facing an LPS challenge.

1.9 Metabolomics

Metabolomics refers to the study of metabolites which are the final products of processes that occur in cells (Agin et al., 2016). The aim is to quantify the multiple small molecules such as amino acids, fatty acids, carbohydrates, or other products of cellular metabolic functions. Metabolite levels and their ratios reflect metabolic function so when levels are out of the normal range, it is probably synonymous of disease (Hasin et al., 2017). The main aim of metabolomics is to identify potential small molecule biomarkers that relate to a disease, drug toxicity, or genetic or environmental variation and to interrogate the metabolic networks in a qualitative and quantitative manner. The first metabolomic studies were published in man in 2000 so it is still regarded as a new scientific discipline and the methodology and technology is still developing. There are just few recent researches on broilers metabolome, mainly on serum (Cao et al., 2020; Afrouziyeh et al., 2022) under physiological conditions. I have only found the study of Wu et al. (2021) who used LPS to challenge broilers and investigate the plasma metabolome profile post challenge.

1.9.1 Methods of studying Metabolomics

As for proteomics, MS is the preferred method for metabolite analyses, but magnetic resonance (NMR) spectroscopy is also widely used. MRS is less sensitive than MS, but it is highly quantitative and has advantages in quantifying metabolites of tissue extracts. MS technique is based on the nuclear spin property of certain nuclei with an odd number of nucleons (protons or neutrons). The resonances of nuclei excited by specific radiofrequencies can be measured to give a distinct signal. In the graphic result, the peak area corresponds to the signal for each metabolite that can be calculated relative to the internal standard to obtain quantitative values. Many classes of molecules in the extracted samples can be examined at the same time.

MS-based metabolomics provides a highly sensitive means of compiling a metabolic profile. The main chromatography methods which are used to separate metabolites before the MS identification are high-performance liquid chromatography (HPLC), gas chromatography (GS), and capillary electrophoresis (CE) (Gowda and Djukovic, 2014). Among these separation methods, Liquid chromatography (LC) and gas chromatography (GC) tend to be the most widely used. However, GC typically requires chemical derivatization of the metabolic species prior to MS analysis while LC can detect a larger pool of metabolites with

no requirement for chemical modification (Ramautar et al., 2019). Nowadays, hydrophilic interaction liquid chromatography (HILIC) is the technique of choice for strongly to slightly polar metabolite separation (Bajad et al., 2006).

Ionization is one of the most critical steps in MS-based studies because it influences the ability to detect and quantify metabolites. Different ionization methods are available such as electrospray ionization (ESI) and electron impact (EI) ionization. ESI is a soft ionization technique which ionizes molecules in the liquid phase and can be used for both small and large molecules, but its efficiency is affected by the presence of salts. EI is a hard ionization method as it causes fragmentation of metabolites, and it enables detection with minimal matrix effects due to co-eluting metabolites (Siuzdak, 2004).

Metabolites detection with high resolution and sensitivity is the goal of each metabolomics study, however higher sensitivity leads to lower resolution and vice versa. There are several MS options that can be used for metabolomics investigations including single (MS) or tandem (MS/MS) mass analysers. For single MS detection different analysers are available: the quadrupole (Q), linear ion trap (LIT) and quadrupole ion trap (QIT) (high sensitivity but limited resolution), time of flight (TOF), fourier transform ion cyclotron resonance (FTICR), and Orbitrap (high mass resolution). For tandem MS detection triple-quadrupole ion trap (QTrap), triple quadrupole (TQ), quadrupole-TOF (Q-TOF), and linear-quadrupole ion trap-Orbitrap (LTQ-Orbitrap) can be used. TQ and Qtrap analysers are mostly used to target specific metabolites because they are characterized by high sensitivity and selectivity, while Q-TOF, LTQ-Orbitrap, and FTICR analysers are suitable for global profiling (Gowda and Djukovic, 2014).

Metabolomics studies are divided into targeted and non-targeted approaches (Ribbenstedt et al., 2018). Targeted metabolomics is aimed to study specific known metabolites (Roberts et al., 2012) while untargeted metabolomics studies all detectable metabolites in a sample without a specific target (Schrimpe-Rutledge et al., 2016). The choose of the preferable method depends on the objective of the project and the knowledge available in the literature on the research topic of interest. As a discovery approach, untargeted analysis, can reveal novel findings and led to the discovery of novel biomarkers (Carneiro et al., 2019). Metabolite data generated by MS are usually complex, and hence multivariate statistical methods are often needed to extract information and perform statistical analysis. Principal component analysis (PCA), an unsupervised method, is generally the starting point used in metabolomics analysis where samples are clustered just based on the variance of the signals

in the metabolite profiles. Then, partial least squares discriminant analysis (PLS-DA), a supervised method, build a predictive model based on the regression of the data matrix (X) against a matrix (Y) including sample information, such as treatment, disease etc per each sample (Agin et al., 2016). Further information on these methods is described in chapter 5.

1.9.2 Investigating the Broilers Metabolome

A recent review suggests that metabolomics studies can be used to predict feed efficiency and residual feed intake (RFI), study diseases, evaluate dietary responses to different dietary treatments, fertility and determine bioproduct content and other important economic or breeding traits associated with livestock (Goldansaz et al., 2017). Indeed it is suggested that metabolic disorders could represent the cause of more economic loss than infections (Julian, 2005). For these reasons, metabolomics approaches are gaining popularity in livestock research.

In broilers few metabolomics studies have been performed and available in the literature. As for proteomics, recent progress in MS technologies has improved the ability to profile metabolites not only in body fluids such as plasma but also directly from tissues. Recently the study of Wu et al. (2021) has used plasma samples to study the metabolome profile of broilers during LPS inflammation and demonstrated that LPS can influence different metabolic pathways. Furthermore, plasma metabolites were shown to be a good indicator of broiler breeder health at 18 to 26 week of age (Afrouziyeh et al., 2022). The study of Barnes et al. (2002) found a decrease in plasma free amino acids during the early phase post LPS challenge suggesting LPS can promote the degradation of amino acids in the early phase of inflammation (Asai et al., 2008). LPS also induces a significant decrease in the expression of genes involved in mitochondrial energy metabolism according to Williams and O'Neill (2018).

The inflammatory response induced by LPS challenge serves as an important model to investigate different liver disorders. LPS induces a significant decrease of intermediates involved in amino acids, energy and carbohydrate liver metabolism (Lieboldt et al., 2016). Based on the literature, plasma and liver samples are good candidates to study the metabolome of broilers subjected to different dietary treatments from a physiological perspective and also to determine if different dietary regimes modulate the APR of broilers under challenge conditions. Bird age also is likely to impact the metabolome of broilers.

Many bacteria in the gut are involved in the modulation of metabolic pathways and as already explained in section 1.6 Microbiota, the intestinal microbial composition is influenced by broiler age. The study of Afrouziyeh et al. (2022) identified a number of metabolite biomarkers that were influenced by sexual maturity in broiler breeders. These biomarkers were mainly involved in lipid, energy, and amino acids metabolism.

Few studies have been performed to investigate the plasma and liver metabolome of broilers. In this thesis the opportunity to apply a metabolomic approach to investigate the effects of citrus or cucumber extracts dietary supplementation on the plasma and liver proteome of broiler chickens reacting to an LPS challenge and to add the existing knowledge base of how broiler chickens react to LPS challenge were felt to be well worthwhile.

1.10 Aims of thesis

Due to the ban of antimicrobial growth promoters in poultry diets, disease treatments are also under much greater scrutiny by the authorities of many countries. A number of different types of food additives have been employed as replacements for antibiotic growth promoters. Two novel plant extracts, citrus and cucumber, not as yet utilized in the field, have shown some promise in limited trials but their mechanisms of action are ill defined. A full picture of the various interplay mechanisms between the microbiota, proteome, metabolome, and the extracts, would allow the confirmation of their value and perhaps suggest more important products in their bioactive components. This I hope would lead to the possible the development of new dietary plans to enhance bird performance and possibly even protect birds from diseases caused by pathogenic bacteria.

The overall aim of this thesis is to investigate the effects of citrus and cucumber dietary supplementation in broiler chickens under control and under LPS challenge conditions. Our hypothesis was that these diets would confer an advantage over the normal diet in terms of performance and resilience to a toxic challenge mimicking a gram-negative infection.

To explore this aim, two *in vivo* trials are described in chapter 2 and 3. The first dietary trial was designed to test the hypothesis that control (CTL) diet supplemented with citrus (CTS)

or cucumber (CMB) extract improves gut health of broiler chickens through the modulation of the gut microbiota, morphology and performance under physiological conditions.

The second dietary trial was designed to study the effects of dietary supplementation (CTL, CTS and CMB diets) on the APR response, proteome, and metabolome of broilers subjected to an LPS challenge.

In chapter 2, samples from trial 1 were used to study the effects of CTS and CMB diets on growth performance, microbiota composition and gut morphometric measurements.

In chapter 3, APR response of broilers on each dietary regimen to the LPS challenge is described in trial 2 (CTL, CTS, CMB) is evaluated by studying established APPs (AGP and SAA) and novel APPs (Hpx, Ex-FABP and MRP-126) at T₀, 12, 24 and 48h post challenge.

A proteomics approach combined with high resolution LC-MS/MS analysis is then used in Chapter 4 to evaluate liver and muscle samples collected in trial 2. This study focuses on changes in proteome of broilers in the first T₁₂h post LPS injection in both control and experimental diets. Proteins of interest are validated by Western Blot (WB) procedure. As well as characterizing the proteome of broilers following the LPS challenge this study also enabled the role of dietary treatments in modulating the overall proteome to be evaluated.

In chapter 5 and 6, using samples of trial 2, an Untargeted metabolomics approach is used to study the plasma metabolome (chapter 5) and liver metabolome (chapter 6) of broilers on each dietary treatment at T₀ pre LPS challenge and 12, 24, 48h post LPS challenge. Biological interpretation of metabolites of interest is described along with a follow-on study which compared the corticosterone levels in the plasma from birds on each dietary regimen.

Finally, in Chapter 7 a general discussion on the whole thesis is provided. This includes a critical evaluation of work done to achieve the aim of this thesis. Recommendations for future work are also discussed.

Chapter 2 The effect of novel plant extracts on gut microbiota assessed by 16s rRNA sequencing

2.1 Introduction

As already mentioned in the previous chapter, there has been a total ban on the use of antibiotics as feed additives in broiler production in the EU since 2006 (Regulation No. 1831/2003 of the European Parliament and of the Council on additives for use in animal nutrition). As a result, there has been a lot of research looking at the use of a wide range of possible alternatives including organic acids, probiotics, prebiotics and plant extracts as described in chapter 1. In most cases the active components associated with many of these alternatives, and their mode of action for example on the gut microbiota or growth performance is essentially unknown or still under investigation. The evaluation of the growth performance of broilers (e.g. body weight, feed intake, feed conversion ratio) is an important parameter for poultry industries to evaluate if a diet could be commercially valuable but most important would be to establish their role on influencing broiler's gut health.

The different regions of the broiler chicken's intestinal tract can be distinguished by differences in morphology and function with the foregut being mainly responsible for digestion and nutrient uptake, the caeca being the primary site of microbial fermentation and the hindgut resorption of residual water and salts. The number of studies focusing on the microbiota composition of the duodenum, jejunum and ileum are quite limited but suggest that they are quite similar (Glendinning and Watson, 2019), however some authors have highlighted that of these regions the ileum harbours the most diverse population of bacteria but that these could be influenced by the proximity to the caeca (Haghighi et al., 2006). The microbiota of the caeca has been studied more extensively than that of the foregut along with associated microbial functional changes including SCFA production (Józefiak et al., 2004). Thus, to get the best overview of how a dietary intervention influences the gut microbiota it was felt to be important to study more than one tissue (Shang et al., 2018). Due to limited funding availability and the knowledge on the gut microbiota composition available in the literature (see 1.6.2 Broilers gut microbiota – chapter 1), the jejunum and caeca were selected as the tissues of interest in the study described below.

The microbial development of a newly hatched chick will be influenced by many factors including diet and the environment to which it is exposed. It is also well documented that the gut microbiota in broiler chickens is influenced by bird age, moving from a more dynamic situation to a “stable” yet more diverse composition with time (Crhanova et al., 2011). Huang et al. (2018b) demonstrated that in the small intestine the bacterial diversity

peaked in broilers at around 14d old, and in the large intestine around day 28. Thus, temporal development and maturation of the gut microbiota must therefore be taken into account when studying the effects of dietary interventions on gut function and health (see 1.6.2 broilers gut microbiota - chapter 1).

High-throughput sequencing of the 16SrRNA gene on the Illumina platform provides a powerful tool to investigate the gut microbiota and the modulatory effects of dietary supplementation in humans and animals (Salipante et al., 2014; Clarridge, 2004; Cuccato et al., 2021). In this study I amplified and sequenced the V3-V4 region of 16SrRNA gene to study the jejunal and caecal microbiota in male broiler chickens fed a commercial diet supplemented with one of two different novel plant extracts, one derived from Citrus fruits and the other extracted from Cucumber (see 1.4.1 Novel plant extracts – chapter 1).

Citrus fruit extracts are known to be particularly rich in pectin (soluble dietary fiber), flavonoids, limonene, carotenoids and essential oils (Salipante et al., 2014), many of which are compounds that have been shown to influence the gut microbiota of broiler chickens (Ebrahimi et al., 2016). Less is known about the active compounds in cucumber derived plant extracts although cucumber is also known to contain vitamins, carotenoids and flavonoids (Vouldoukis et al., 2004). The presence of some similar active components to those found in citrus fruit extracts therefore makes cucumber extracts a novel candidate for further investigation.

2.2 Aims and Objective of the study

The main aim of this study is to test the hypothesis that the feed of broiler chickens, supplemented with citrus or cucumber extracts, have a positive effect on gut health and the mode of action is mainly mediated through modification of the gut microbiota. To investigate this aim the effects of commercial citrus or cucumber extract supplementation on growth performance (body weight, feed intake, feed conversion ratio), gut morphology and the lumen/mucosal scrape for gut bacterial microbiota (Jejunum and caeca) were compared in male broiler chickens at 14 and 28d of age.

2.3 Materials and Methods

2.3.1 Trial 1 Experimental design

A total of 120 one-day-old vaccinated male broiler chickens (Ross 308) were collected from the PD Hook Hatcheries Ltd, Bampton, UK and raised for 28 experimental days at Cochno farm & Research Centre, Glasgow. Male broilers were considered the preferable choice to maintain consistency among samples. Broilers were fitted with unique wing tags weighed and for welfare reasons totally randomly allotted to one of the three diets: Diet 1) control (CTL): commercial starter and then grower diets without any supplements, Diet 2) cucumber (CMB): diet 1 supplemented with cucumber extracts (75 g/ton diet), Diet 3) citrus (CTS): diet 1 supplemented with citrus extracts (300 g/ton diet). The basal starter diet (day 0–14) and grower diet (day 14–28) were corn-soybean meal-based diets, formulated and prepared at NuScience, Ghent, Belgium (Table 2.1). Each group of broilers was given free access (*ad libitum*) to water and feed throughout the trial. Chicks were distributed in groups of 10 and raised in 12 pens (4 replicate pens/each diet- randomly allocated) across two rooms with dimensions of 150 cm in width and 220 cm in length. Each pen was fitted with a spot brooder and litter was to a depth of approx. 10cm at the start of the experiment and top dressed as required throughout the trial. The lighting and heat regimen applied followed Ross 308 breeder management guide recommendations; 23h light, 1 hour dark lighting cycle for the first 7d reduced then to 18h until day 28. The temperature was set at 35°C at day 0 that was gradually reduced to 20°C at day 28 with the humidity > 50%. Biosecurity measures (i.e protective clothing, footwear, control access to pens, records of visitors) were applied to prevent the risk of cross contamination between pens and rooms. The animal experiment was approved by the Home Office, Animals in Science Regulation Unit (ASRU), Glasgow, under the license number P4A4CA831.

	Starter diet (0 to14 d)	Grower diet (14 to 28 d)
Corn	25,000	25,000
DL-methionine	0,107	0,081
L-Lysine HCl	0,234	0,266
L-Threonine	0,097	0,105
Minevita Bro	3,000	3,000
Monteban 100	0,060	0,060
Sodium Bicarbonate	0,196	0,089
Soya bean meal 47%CP + 2%CP	27,450	22,114
Soya bean oil refined	1,880	3,072
Soya beans Danex	7,500	7,500
Vit Choline Chloride 60% Veg.	0,010	0,010
Vitamin premix	0,010	0,010
Wheat enzymes	34,456	38,636
Monocalcium Phosphate	0,000	0,031
Salt	0,000	0,025

Table 2.1 Feed ingredients (g/100kg) of basal diet for broiler chickens

2.3.2 Growth performance

Starting from the random weighing and allocation to experimental pens on day 0, the body weight (BW) was again recorded at day 7,14 (starter diet) (N=118) and then day 21 (N=84) and 28 (N=35) (grower diet) of the trial using a weight balance (0.001 g). Feed intake (FI) was measured by weighing the feed and feeders for each pen at day 0 and then again at day 7, 14, 21 and 28. Feed conversion ratio (FCR) was calculated as cumulative feed intake (kg) at day 7, 14, 21 and 28 divided by total body weight (kg) of the birds in each pen. A general linear model (GLM) was run on RStudio (version 4.0.0) to test the main effects of diet and bird age (14 and 28d) and their interactions. Tukey's multiple comparisons test were applied where differences were observed.

2.3.3 Tissue Sample collection

For the microbiota investigation 12 broilers per diet (3 broilers per replicate diet) were randomly selected after weighing at 14, and 28d, and immediately euthanized by Schedule 1 procedure: each chicken was culled through the overdose of a Barbiturate anaesthetic agent (1ml/kg of Pentobarbital sodium R Euthatal Dopharma Research B.V.), injected into the brachial vein. The sex of each bird was checked after culling. This resulted in 3 females being identified and excluded from the study to maintain the consistency of samples. Lumen/mucosal scrapes of the proximal jejunum (first 5cm), and one caeca (entire length) from each bird, including digesta, were collected by scraping the tissue with a glass slide (11

samples/diet/ birds age/ tissue); the contents were then placed into an Eppendorf and snap-frozen (-80°C). Tissue sections (5cm) of the jejunum were also collected for morphometric assessment and placed directly into vials with 20 ml of 10% buffered-neutral formalin (BNF). After 24-48h (fixation process), the medium was substituted with 70% of ethanol and samples stored at 4°C.

Additional lumen/mucosal scrapes from the duodenum, distal jejunum, and ileum, together with additional tissues collected for histology (duodenum and ileum) at each sampling birds age were also collected and stored for future use.

2.3.4 Gut morphometric measurements

Jejunum tissues samples were processed using standard methods (dehydrated in graded series of ethanol, paraffin embedded, sectioned, and then stained with haematoxylin-eosin) by the veterinary diagnostic service team at the University of Glasgow. Each histological section was then evaluated using standard light microscopy. Morphometric measurements: villus length (A), crypt depth (B) and epithelium height (C) were explored using NIH ImageJ software (Wilson et al., 2018) (Ferreira and Rasband, 2012) (Figure 2.1). Measurements were made from photomicrographs taken at 4× magnification with a scale of 200 μ m (367.585 image pixels). In total n=6 randomly selected birds per diet at age 14 and 28d old were evaluated and a total of 5 regions of interest (RIOs) were measured on each tissue section. The average values for each measurement per bird were statistically analysed in RStudio to study the effect of diet and collection day (bird age) using GLM. Then, Tukey's pairwise comparisons (95% of confidence) were applied where significant differences were observed for the main effects of diet and age and their interactions.

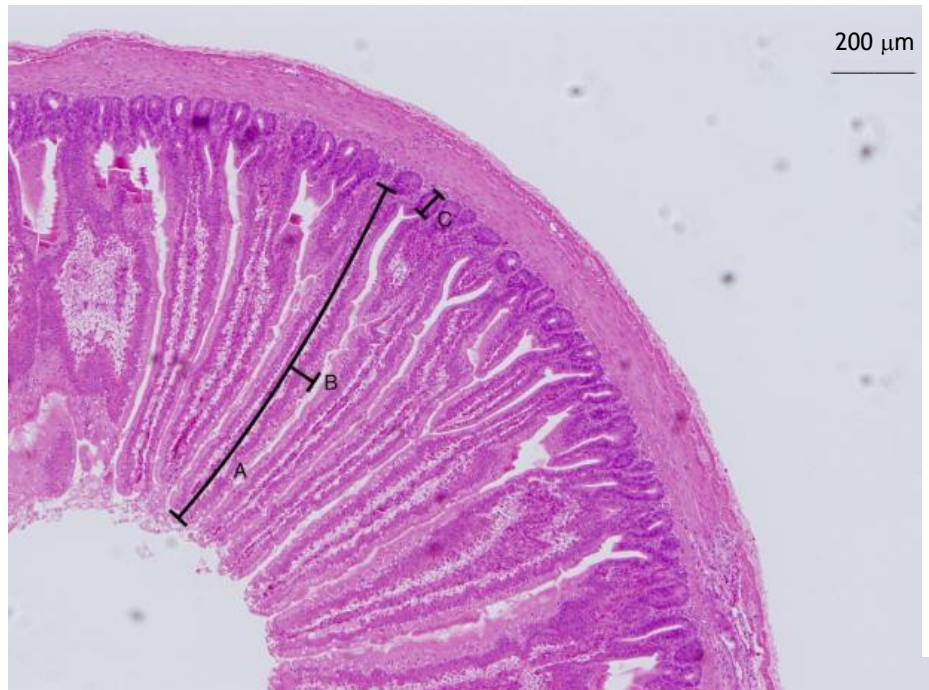

Figure 2.1 Morphometric measurements carried out on histological sections of the Jejunum Villus length (A), epithelium height (B) and crypt depth (C) are shown.

2.3.5 Microbiota summary workflow

Figure 2.2 summarises the pipeline used in the microbiota investigation. Each step of the pipeline is explained below but in brief the DNA of each sample was extracted using the DNeasy PowerSoil Pro kit (Qiagen, Manchester, UK) and amplified by a 2-step 16S specific-PCR which used the V3-V4 region as target (Bukin et al., 2019). Following the PCR, the amplicons were quantified and diluted to an equimolar concentration, the Illumina library was prepared, and samples sequenced using the Illumina MiSeq platform (Illumina, San Diego, CA, USA). To ensure the accuracy and reliability of the sequenced data, a quality control (QC) was performed at each step of the procedure. Once sequences were obtained, they were then analysed using QIIME Software v2. α and β diversity analysis was used to study respectively the within and among samples diversity. Linear discriminant analysis effect size (LEfSE) was used to identify specific bacterial strains in samples of the bacterial community modulated by one of the experiment variables (e.g diet, tissue, bird age). All analyses as described were carried out at Glasgow Polyomics facilities (UK) under the supervision of experienced personnel.

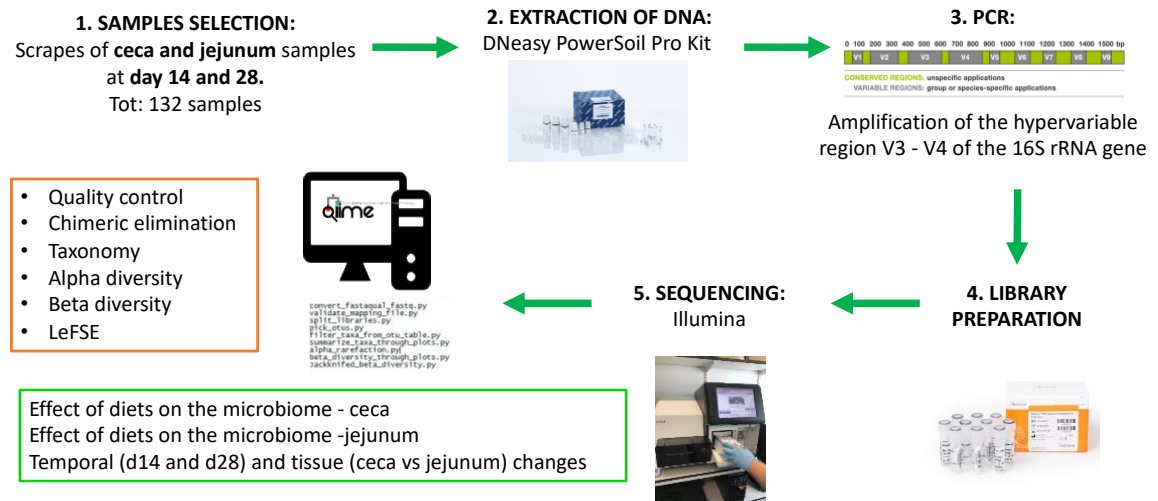

Figure 2.2 Pipeline of the microbiota investigation

Scrapes of jejunum and caeca were selected at d14 and d28, DNA was extracted and the region V3-V4 of the 16S rRNA gene was amplified by PCR. Once the Illumina library was prepared, samples were sequenced through the Illumina technology and then the QIIME software was used to perform QC of sequences, chimeric elimination and taxonomy observations. Alpha (α)-Beta (β) diversity and LEfSE analysis was used to observe the effects of diet on the caeca and jejunum microbiota and the associated temporal (d14 and d28) and tissue (caeca and jejunum) differences.

2.3.5.1 DNA extraction

The genomic DNA was extracted from each of the 132 samples (11 samples/3 diets/2 age groups /2 tissues) and a blank (water as negative control) following the protocol of DNeasy PowerSoil Pro kit (Qiagen, Manchester, UK). The kit was used according to the manufacturer's instructions with slight adaptations, based on the protocol optimization by experienced personnel in Polyomics; these alterations are described below.

Approximately 250 mg of each sample was placed in bead tubes with 800ul of lysis buffer (PowerSoil[®] solution CD1), provided by the kit, and vortexed at maximum speed for 10 minutes. Samples were then centrifuged at 15,000 x g for 1 minute and 1.5 ml of supernatant transferred to a clean 2 ml tube. The next step in the process involved removal of inhibitors from the sample by adding 200ul of the inhibitor reagent that can precipitate non-DNA organic and inorganic material including proteins (PowerSoil[®] solution CD2). The sample with inhibitor was centrifuged for 1 minute at 15,000 x g, before transferring the supernatant to a clean 2 ml tube. The DNA salt concentration was then adjusted by adding 600ul of a high concentration salt solution (PowerSoil[®] solution CD3) to the lysate. This was vortexed briefly and then 650ul transferred to the spin column supplied with the kit and centrifuged for 1 minute at 15,000 x g to allow the DNA to bind to the silica membrane. The DNA bound to the silica membrane was then washed first with 500ul of wash buffer 1, which removes proteins and other non-aqueous contaminants from the MB Spin Column filter membrane

(PowerSoil[®] solution EA) and then with 500ul of an ethanol-based wash solution (PowerSoil[®] solution C5), and then eluted with 100ul of elution buffer (PowerSoil[®] Solution C6). The DNA concentration and purity were controlled by the High Sensitivity DNA Qubit system (ThermoFisher, Paisley, UK). The DNA concentration, ng/ μ L, was assessed at 260 nm and the purity was controlled using the 260 nm/280 nm wavelength ratios.

2.3.5.2 16S Illumina Sequencing

Once samples were diluted in equimolar concentrations, the hypervariable V3-V4 regions of the bacterial 16S rRNA gene were amplified with a specific 2-step PCR aimed to prepare the 16S Illumina sequencing library. A total of 12.5 ng DNA per sample and a negative control (water at first PCR step) was used for this procedure. This technique is summarised in Figure 2.3 and is based on the ability of DNA polymerase to synthesize a new strand of DNA, complementary to the template strand. The DNA polymerase is a magnesium-dependent enzyme that must be used with adequate concentration of Mg^{2+} to avoid a lower product yield. This enzyme cannot work without a primer, which adds the first nucleotide only in a pre-existing 3'-OH group. The primer sequence is specific for a determinate region, and it allows the amplification of a chosen specific region of the target DNA which leads to the formation of a single amplicon of approximately -460 bp.

In the Illumina protocol, the following primer sequences were recommended to be used for amplifying the V3-V4 regions of the 16S rRNA gene:

16S Amplicon PCR Forward Primer: 5'-CTTACGGGNGGCWGCAG- 3',

16S Amplicon PCR Reverse Primer: 5'-GACTACHVGGGTATCTAATCC- 3'.

These primers were selected from the study by Klindworth et al., (2013) and the specific target regions were amplified. Illumina primers are also designed to include a locus specific sequence which is used during the indexing PCR step to make them compatible with Nextera[™] XT v2 identifier indices and sequencing adapters (those properties are fundamental for the second PCR reaction).

The first PCR was performed by initial denaturation at 95°C for 3 min and then 25 cycles at 95°C (30 sec), 55°C (30 sec), 72°C (30 sec) and the final elongation step at 72°C for 5 min. AMPure XP beads were used to purify the 16S V3 and V4 amplicon from free primers and primer dimer species. Then, a second PCR reaction was performed using the Nextera XT Index Kit which attached dual indices and Illumina sequencing adapters to the amplicon sequence. This second PCR reaction was performed by initial denaturation at 95°C for 3 min and then 8 cycles at 95°C (30 sec), 55°C (30 sec), 72°C (30 sec) and the final elongation

step at 72°C for 5 min. AMPure XP beads were used to clean up the final library before the quantification stage. Then the amplicons were quantified by the High Sensitivity DNA Qubit system (ThermoFisher, Paisley, UK) and ready to be sequenced by the Illumina MiSeq platform (Illumina, San Diego, CA, USA).

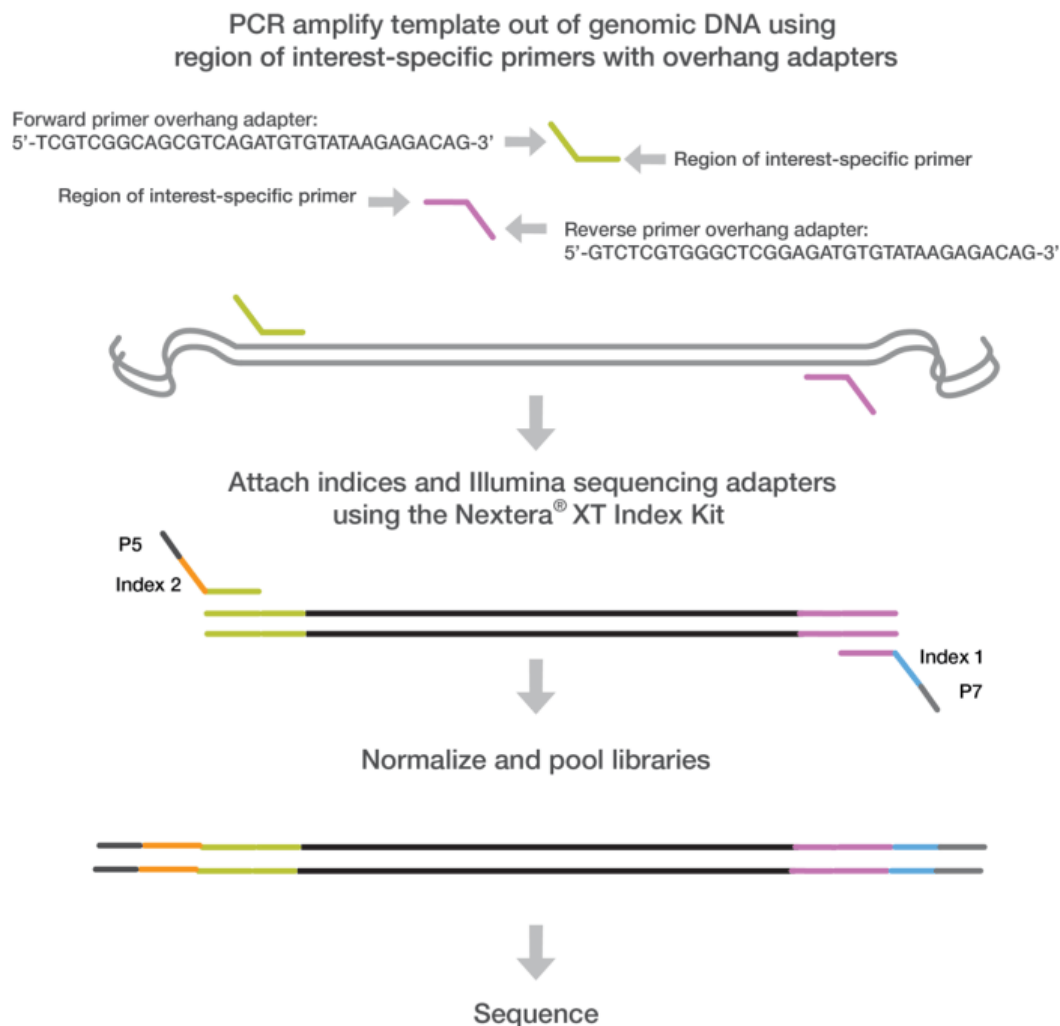

Figure 2.3 16S Illumina Sequencing Library preparation workflow

Forward and reverse primers, complementary to the region of interest (V3-V4) and designed to contain adapters, are used to amplify templates from genomic DNA in the first PCR step. Then, a subsequent PCR amplification step is performed to add Illumina adapters and multiplexing indices. Libraries obtained are normalized, pooled and sequenced in the MiSeq Illumina platform (Image Source: Preparing 16S Ribosomal RNA Gene Amplicons for the Illumina MiSeq System guideline - https://support.illumina.com/documents/documentation/chemistry_documentation/16s/16s-metagenomic-library-prep-guide-15044223-b.pdf).

2.3.5.3 QIIME™ software and bioinformatics analysis

Sequence reads were analysed by Quantitative Insights Into Microbial Ecology (QIIME) 2™ (Caporaso et al., 2010). This software is an open-source bioinformatics pipeline that performs microbiome analysis from raw DNA sequencing data and generates graphics and textual outputs from different communities of fungi, viruses, bacteria and archaea to obtain

taxonomic assignment and phylogenetic reconstruction. QIIMETM can be used for studies that considers thousands of samples (Kuczynski et al., 2012). A mapping file (called metadata) including all information about the sample ID, the barcode sequence, the linker and reverse primer sequence, diet, pen, animal number, tissue, and file description (fasta file format) was created before starting the analysis in QIIMETM. The metadata file allows the software to recognise each sequence and to attribute the specific descriptions to each sample so it's fundamental to make it accurate as soon as the analysis starts. The scripts used in this investigation are provided in Appendix A at the end of this thesis.

In the current workflow, quality control (QC) of sequences was performed by trimming and filtering sequences based on their quality scores and by detecting and removing the chimeric sequences. The sample's sequences were first demultiplexed, assigned to individual samples according to the specific indexes of each sample, trimmed using the Cutadapt v1.12 Python package (Martin, 2011) and poor-quality reads were removed. Trimmed reads were merged into a single read using Pandaseq v2.10 (Masella et al., 2012) and sequences that did not meet the QIIMETM quality criteria were excluded (minimum sequence count: 5000 sequence/sample). Based on these parameters the lowest sequence count encountered was 5259 sequences/sample while the maximum reached a total of 68195 sequence/sample. Most caecal samples showed a higher number of sequences per sample than the jejunum samples. The remaining quality-filtered reads were clustered *de novo* (97% similarity threshold) into operational taxonomic units (OTUs) and the most abundant sequence was selected as the OTU representative (Caporaso et al., 2010). There are three different protocols for the generation of the OTUs: *De novo* OTU picking, Open reference OTU picking and Closed reference OTU picking. For this analysis, the Open reference OTU Picking was used in order to compare overlapping amplicons (Caporaso et al., 2010). The alignment of sequences was performed against the Greengenes core set (16S rRNA gene database) with the PyNAST method.

The taxa summary (taxonomy) describes the abundance of OTUs in each group (e.g diet, tissue or bird age) from phylum to genus level. The information on OTUs abundance were normalized using a standard of sequence number representing the sample with the least sequences. Subsequent analysis was all performed basing on this output normalized data. In our study, taxonomy was explored based on CTL, CTS and CMB diets in both jejunum and caeca samples; the distribution of phylum and family OTUs was studied by observing the percentage of specific taxa in each group. Diversity analyses (statistical evaluation) were

then carried to assess the microbial community diversity within each sample (α -diversity) and among samples (β -diversity) based on different diet administration (CTL, CTS, CMB), tissue (jejunum vs caeca) and bird age (14 vs 28d old).

For the metrics “ α -diversity” the species richness (Chao1) and the phylogenetic diversity (PD_whole_tree) were considered. These indexes of α -diversity were used to generate rarefaction curves (random collection of sequences from a sample, with a specified depth) which indicated if our variables differ in terms of within-sample microbial composition. The β -diversity Student's unpaired T-tests (Bonferroni-corrected) to study differences among pairs of samples. It graphically generated a Principal Component Analysis (PCA) plot which allows the visualisation of differences among samples through the UniFrac phylogenetic distance matrix (Weighted and Unweighted UniFrac matrices). Weighted Unifrac distances consider the abundance of each taxon, while unweighted distances take into account only the presence or absence of data (Lozupone et al., 2011; Edgar, 2010). The Taxa summary, α and β diversity diversity was performed using a table filtered for chloroplast and 0.005% abundant sequences.

Finally, LEfSE was used to identify specific bacterial strains that were modulated by diet (CTL vs CTS and CTL vs CMB), tissue (caeca vs jejunum) or bird age (day 14 vs day 28). The LEfSE algorithm uses the nonparametric factorial Kruskal- Wallis test ($\alpha = 0.05$) to analyse differences between classes (e.g diets) and the pairwise Wilcoxon test ($\alpha = 0.05$) to show differences among subclasses (e.g birds age / gut sites) within different classes.

2.4 Results

2.4.1 Growth performance

A significant interaction ($p < 0.001$) was found for BW for each of the dietary treatments with bird age. The number of broilers decreased by age because chickens were culled (3birds x each pen) at day 14, 21 (samples used for another project) and 28 (5 females were also excluded from the analysis and, 8 broilers at day 28 were used by an associated project). There was no difference in BW (Kg) at day 0 and 7d of age while a significant difference was observed at day 14, 21 and 28 ($p < 0.05$) with the control birds being heavier than either the CTS or CMB birds from day 14 (Figure 2.4).

A significant interaction ($p < 0.001$) between diet and birds age was found for feed intake (FI) as well. FI was significantly lower in the CTS dietary treatment compared to CTL diet at 7 and 21d of age ($p < 0.05$) while no differences were observed at d14 and 28. On the other hand, broilers fed with the CMB supplemented diet showed a significantly lower FI compared to CTL at all time points ($p < 0.05$) (Figure 2.5).

No interaction between diet and bird age was observed for FCR. In terms of dietary effects, the broilers fed the CTS diet showed a significantly higher FCR compared to those fed the CTL diet ($p < 0.05$) while the broilers fed the CMB had a similar FCR to the CTL group (Figure 2.6A). The FCR increased with increasing bird age in all three diets (Figure 2.6B).

	Diet	Day 0			Day 7			Day 14			Day 21			Day 28		
		N	Mean	± SE	N	Mean	± SE	N	Mean	± SE	N	Mean	± SE	N	Mean	± SE
<i>BW</i> (kg)	CTL	37	0.035	± 0.000 ^a	36	0.169	± 0.002 ^b	36	0.441	± 0.007 ^c	24	0.867	± 0.018 ^c	11	1.392	± 0.032 ^g
	CTS	39	0.038	± 0.000 ^a	38	0.146	± 0.003 ^b	38	0.379	± 0.008 ^d	26	0.752	± 0.020 ^f	10	1.228	± 0.073 ^h
	CMB	38	0.037	± 0.001 ^a	38	0.147	± 0.002 ^b	38	0.374	± 0.007 ^d	25	0.752	± 0.018 ^f	12	1.218	± 0.034 ^h

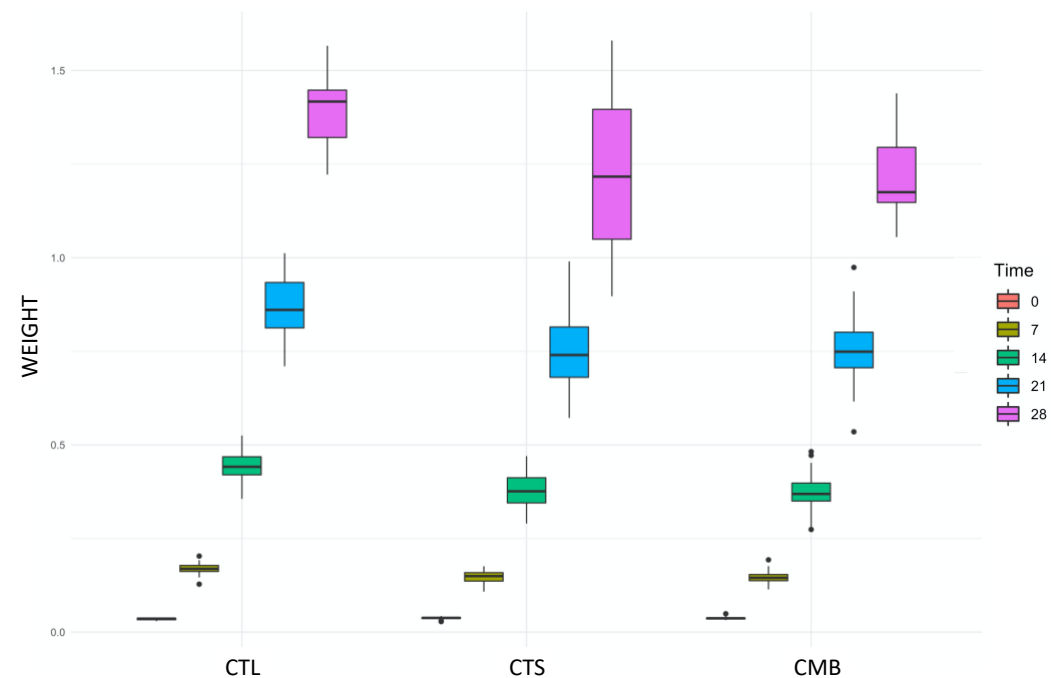

Figure 2.4 Body weight (Kg) of broilers on CTL, CTS and CMB supplemented diets at 0,7,14,21,28d of age

The table indicates the number of broilers (N), the mean and standard error of the mean (SE). Means that do not share a letter are significantly different ($p < 0.05$). The data is also represented in the accompanying box plot (mean \pm SD). The broilers fed with CTS and CMB supplemented diets had a significantly lower body weight ($p < 0.05$) compared to those fed the CTL supplemented diet at 14,21 and 28d of age.

<i>FI (Kg)</i>	Diet	<i>Day 7</i>			<i>Day 14</i>			<i>Day 21</i>			<i>Day 28</i>		
		N	Mean	SE	N	Mean	SE	N	Mean	SE	N	Mean	SE
	CTL	36	0.029	± 0.001 ^a	36	0.052	± 0.001 ^c	24	0.089	± 0.001 ^c	11	0.124	± 0.002 ^h
	CTS	38	0.023	± 0.000 ^b	38	0.052	± 0.001 ^c	26	0.084	± 0.001 ^f	10	0.120	± 0.003 ^h
	CMB	38	0.024	± 0.000 ^b	38	0.048	± 0.000 ^d	25	0.080	± 0.001 ^g	12	0.110	± 0.003 ⁱ

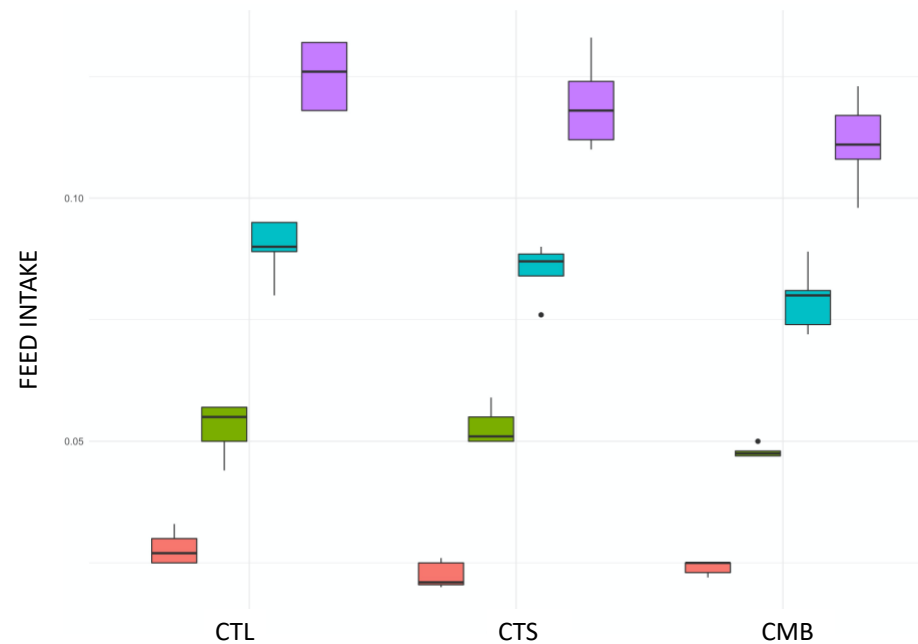
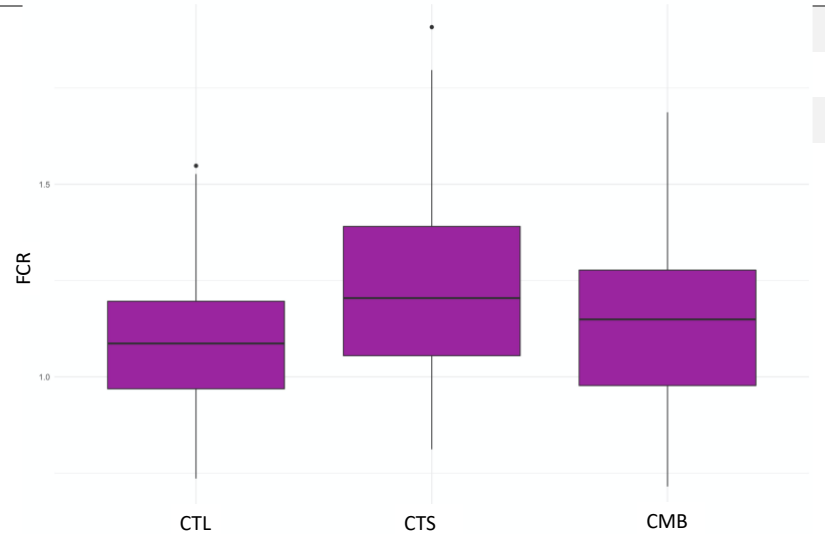

Figure 2.5 FI (Kg) of broilers on CTL, CTS and CMB supplemented diets at 7,14,21,28d of age

The table indicates the number of pens (N), mean and standard error of the mean (SE) referred CTL, CTS and CMB diet. Means that do not share a letter are significantly different ($p < 0.05$). Data are also figured by a bar chart (mean \pm SD) which indicates that broilers fed with CTS diet have a significantly lower FI ($p < 0.05$) compared to CTL at day 7 and 21. Broilers fed with CMB showed a significant lower FI compared to CTL at all time points.

	<i>Diet</i>	<i>N</i>	<i>Mean</i>	\pm	<i>SE</i>
<i>FCR</i>	CTL	107	1.101	\pm	0.018 ^b
	CTS	112	1.230	\pm	0.023 ^a
	CMB	113	1.150	\pm	0.020 ^b
	Diet	N	Mean	\pm	SE



A

	<i>Age</i>	<i>N</i>	<i>Mean</i>	\pm	<i>SE</i>
<i>FCR</i>	7	112	0.96	\pm	0.010 ^a
	14	112	1.20	\pm	0.017 ^b
	21	75	1.29	\pm	0.021 ^c
	28	33	1.41	\pm	0.027 ^d

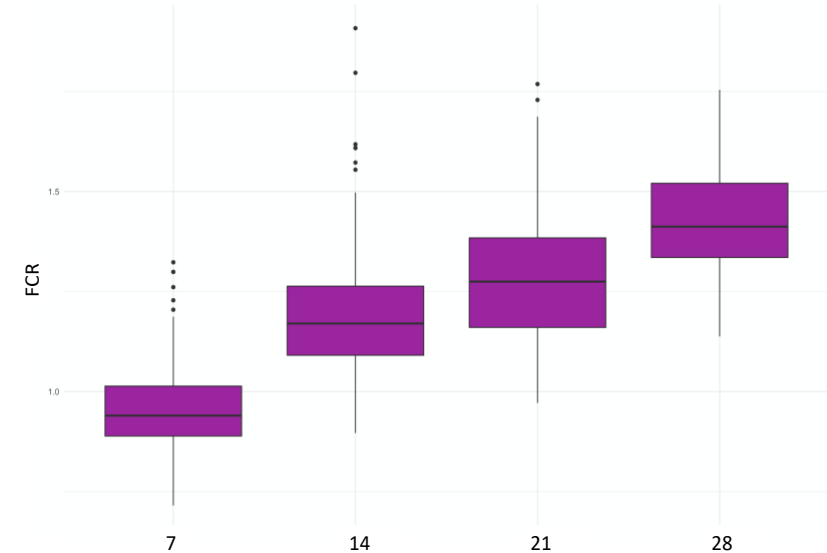

B

Figure 2.6 FCR of broilers by diet (A) and bird age (B)

The tables indicate the number of broilers (*N*), the mean and standard error of the mean (*SE*) for CTL, CTS and CMB diets (**A**) and 7,14,21,28d of age (**B**); means that do not share a letter are significantly different ($p < 0.05$). Both diet and age effects are also presented as a box plot (mean \pm SD). Broilers fed the CTS diet had a significantly higher FCR ($p < 0.05$) compared to those fed the CTL diet while no differences were observed between birds fed the CTL and CMB diets (**A**). The FCR increased with bird age (**B**).

2.4.2 Jejunum morphometric measurements

Table 2.2 indicates that there was no interaction observed for diet and bird age for villus length or epithelium height. A significant increase in villus length was observed in all dietary treatments from 0 to 28d of age ($p < 0.05$) but diet had no effect. The epithelium height did not change with either diet or bird age.

The Crypt depth was found to increase with bird age in the birds fed the CMB diet. No other dietary or age-related changes were observed.

	Diet	<i>Day 14</i>				<i>Day 28</i>			
		N	Mean	SE		N	Mean	SE	
<i>Villus length</i> (μm)	CTL	6	735.10	±	77.40 ^a	6	935.30	±	43.60 ^b
	CTS	6	748.80	±	70.60 ^a	6	1006.70	±	85.30 ^b
	CMB	6	710.70	±	50.90 ^a	6	873.20	±	76.20 ^b
<i>crypt depth</i> (μm)	CTL	6	70.81	±	2.92 ^{cd}	6	75.05	±	1.52 ^c
	CTS	6	68.83	±	2.21 ^{cd}	6	72.71	±	1.61 ^c
	CMB	6	62.81	±	0.97 ^d	6	77.02	±	2.42 ^c
<i>epithelium height</i> (μm)	CTL	6	57.12	±	5.21 ^e	6	68.04	±	5.84 ^e
	CTS	6	63.55	±	6.29 ^e	6	62.40	±	3.76 ^e
	CMB	6	67.74	±	5.58 ^e	6	60.49	±	5.31 ^e

Table 2.2 Jejunum measurements (μm) of villus length, crypt depth and epithelium height at day 14 and 28 for each dietary treatment (CTL, CTS and CMB)

The table indicates the number of samples (N), mean and standard error of the mean (SE). Means that do not share a letter are significantly different. No significant differences were found in villus length, crypt depth and epithelium height, at day 14 or day 28 for broilers fed with CTS or CMB diets. A significant age effect ($p < 0.01$) was observed in villus length for all dietary treatment, crypt depth also increased in the birds fed the CMB diet.

2.4.3 Jejunum Microbiota Taxonomy

In the first level of analysis, taxonomy data from phylum to family level was studied in the jejunum and caeca separately.

Jejunal tissue taxonomy was studied with reference to diet (CTL, CTS and CMB) and bird age (day 14 and 28). At phylum level, *Firmicutes* predominated (>90%), followed by *Actinobacteria*, *Proteobacteria* with a low percentage of *Bacteroidetes* and *Verrucomicrobia*. Slightly differences were discovered in the abundance of some bacterial strains at birds age 14 and 28 in jejunal tissues associated with the CTS and CMB diets (e.g higher abundance of *Actinobacteria* in birds fed with CTS diet at 14d old compared to birds fed with CTL and CMB diets at the same age and lower abundance of *Proteobacteria* at 28d old in both experimental diets CTS and CMB compared to CTL in birds of the same age group). However, these differences were not found significant for each diet based on bird age (14 vs 28d) (Figure 2.7).

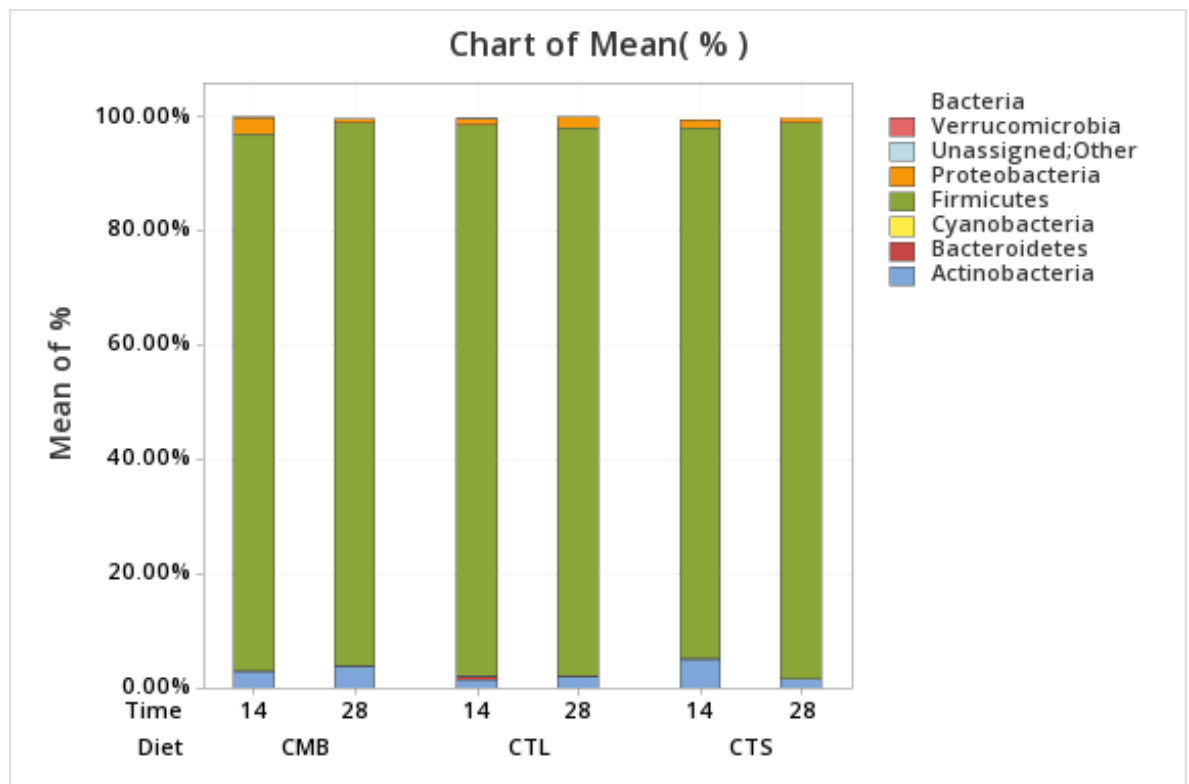

Figure 2.7 Taxonomy (phylum level) comparison of CTL, CTS and CMB diets in jejunum samples collected from broilers at 14 and 28d old

Firmicutes represent the predominant phylum in each dietary and age group; differences for each diet based on bird age (14 vs 28d old) were not found significant.

Taxonomy at family level is summarised in Figure 2.8. *Lactobacillaceae* followed by *Enterococcaceae*, *Streptococcaceae* and *Lachnospiraceae*, were identified as the most

abundant families in birds of 14 and 28d old. Although differences in the abundance of some bacterial strains were observed (e.g higher abundance of *Lactobacillaceae* at both age in birds fed with CTS diet compared to CTL and CMB diets) there was no significant difference in terms of overall taxonomy modulation depending on dietary treatments and birds' age.

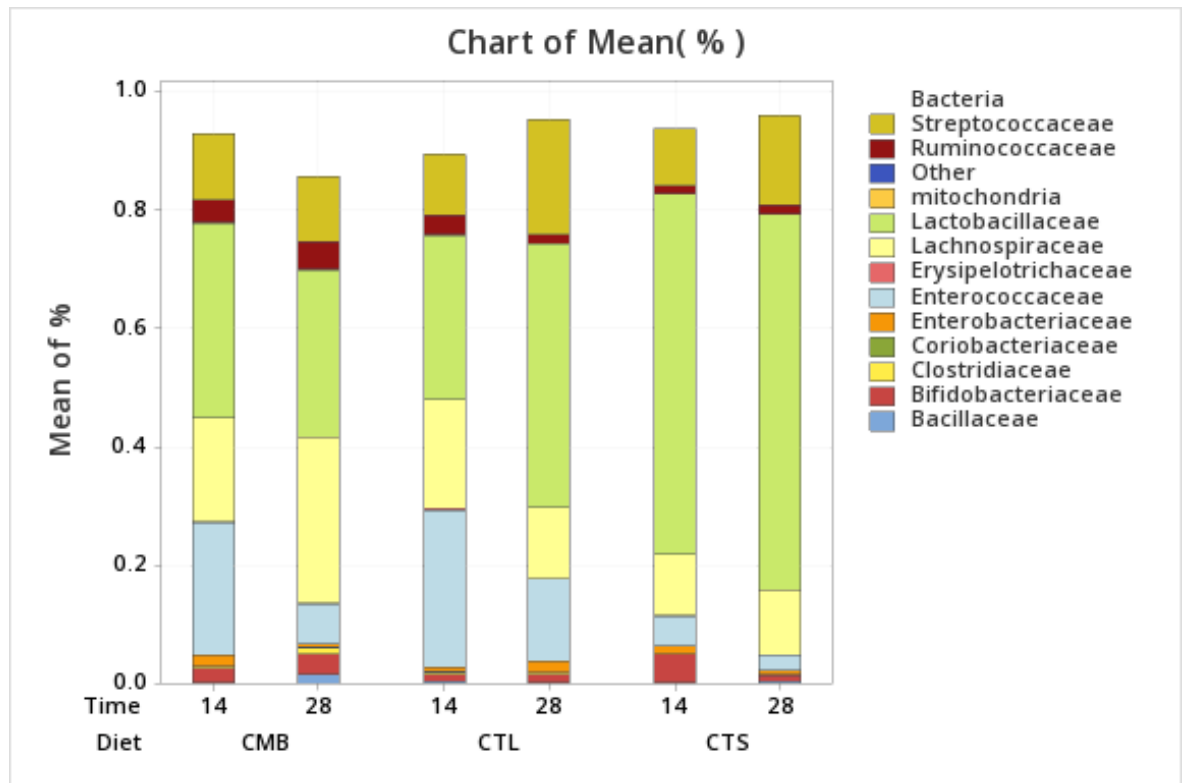

Figure 2.8 Taxonomy (family level) comparison of CTL, CTS and CMB diets in jejunum samples collected from broilers at 14 and 28d old

Subtle difference can be observed between the diets and age groups, but these were not found to be statistically significant.

2.4.4 Caeca Microbiota Taxonomy

At phylum level, the caecal microbiota was dominated by *Firmicutes*. A low percentage of *Actinobacteria*, *Bacteroidetes*, *Proteobacteria*, *Cyanobacteria* and *Verrucomicrobia* was also detected. The abundance of each phylum for each of the three dietary treatments at day 14 and 28 is summarised in Figure 2.9. The taxonomy at phylum level, based on the bird's age (14 and 28d old) for each diet, was found significant ($p < 0.05$).

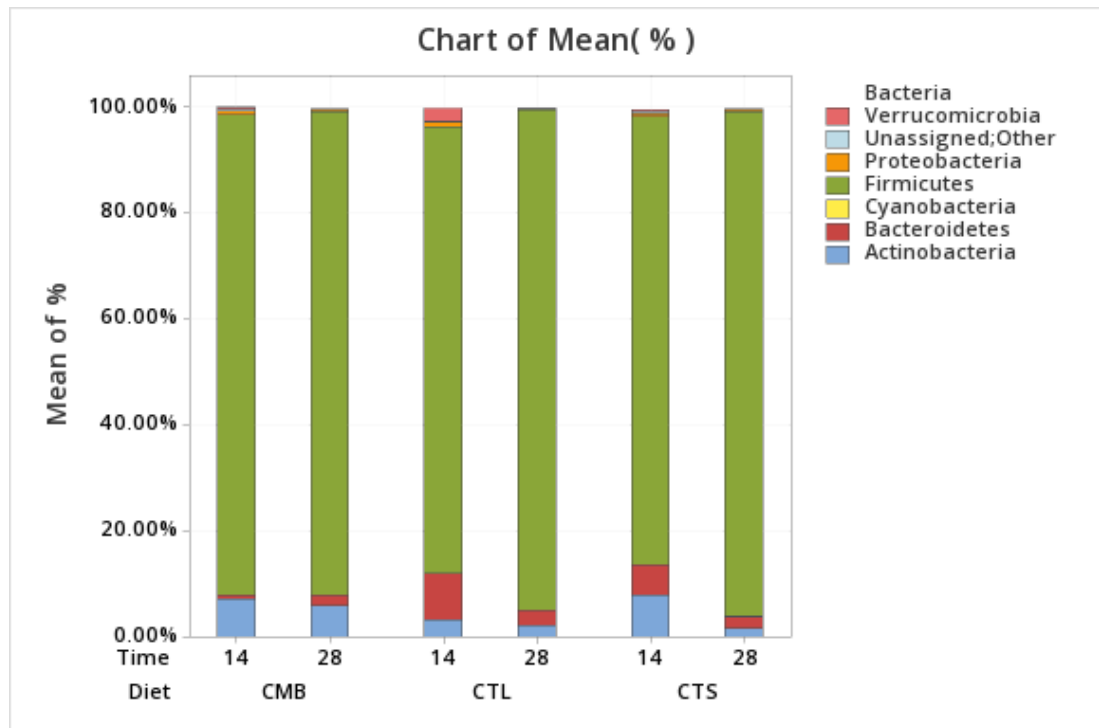

Figure 2.9 Taxonomy (phylum level) comparison for CTL, CTS and CMB diets in the caeca of broilers sampled at 14 and 28d old

Firmicutes represent the predominant phylum in each dietary and age group; differences for each of the three diets based on bird age (14 vs 28d old) were found significant.

Taxonomy was also studied at family level in the caeca for each diet and age (Figure 2.10); the most abundant families identified in each dietary group at both birds age was *Lachnospiraceae* and *Ruminococcaceae*. Subtle differences in the abundance of bacterial strains at family level were observed based on different birds age and diets but the overall taxonomy was not found to be strongly significant at this level ($p = 0.05$).

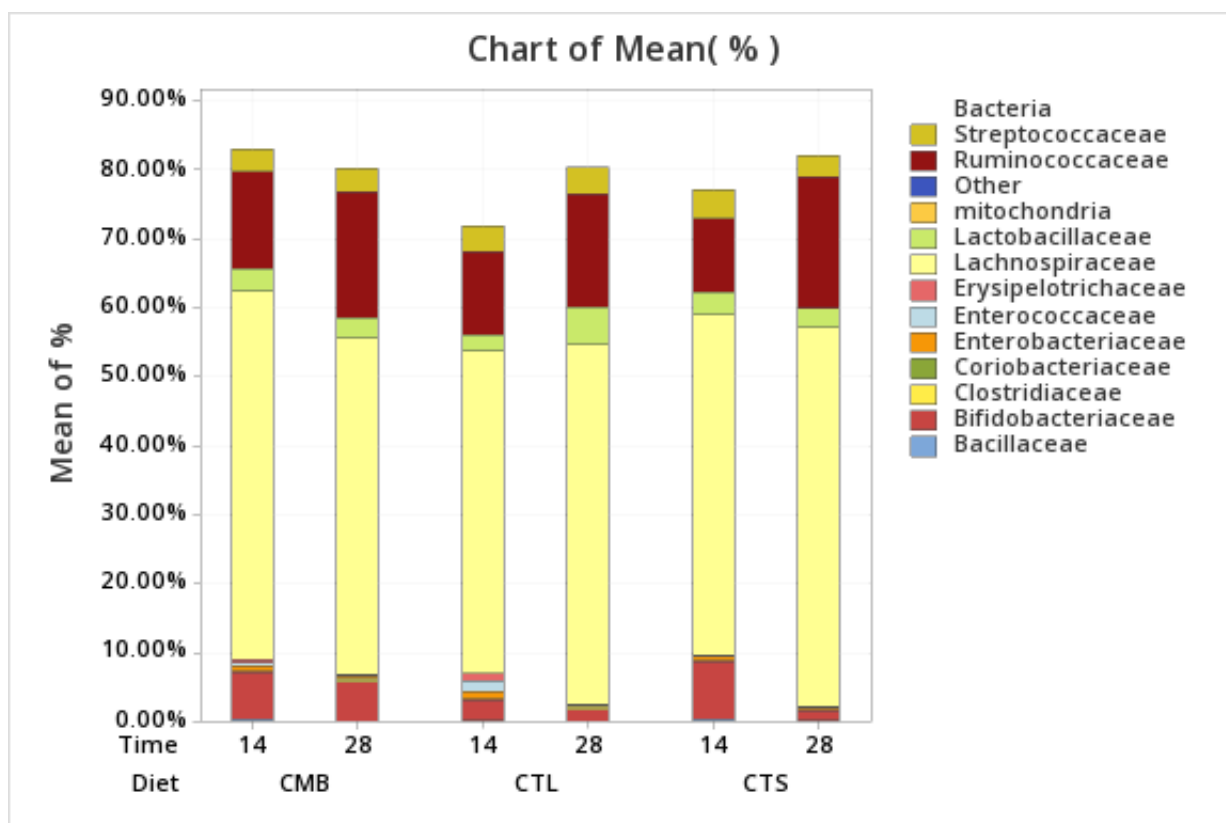

Figure 2.10 Taxonomy (family level) comparison for CTL, CTS and CMB diets in the caeca of broilers sampled at 14 and 28d old

Lachnospiraceae and Ruminococcaceae represent the predominant families in each dietary and age group; differences in taxonomy at family level were not found to be significant.

2.4.5 Dietary effects on the jejunal microbiota

The within community α -diversity was assessed by calculating Chao1 and PD whole tree indices and no dietary effects were observed ($p > 0.05$) (Table 2.3). Rarefaction curves for each dietary treatment are presented in Figure 2.11A, B. Each rarefaction curve follows the same trend and approaches a plateau. This indicates that the sequencing depth (0 to 5000 sequences per sample) was sufficient to cover all the OTUs.

α -diversity index	Diet 1	Diet 2	Diet 1 mean	SD	Diet 2 mean	SD	<i>p</i>
<i>Chao1</i>	CTL	CTS	232.82	± 57.77	243.14	± 53.53	~1.00
	CTL	CMB	232.82	± 57.77	237.21	± 51.67	~1.00
	CTS	CMB	243.14	± 53.53	237.21	± 51.67	~1.00
<i>PD_whole_tree</i>	CTL	CTS	7.58	± 1.50	8.15	± 1.65	0.81
	CTL	CMB	7.58	± 1.50	8.20	± 1.65	0.66
	CTS	CMB	8.15	± 1.65	8.20	± 1.65	~1.00

Table 2.3 Data of α -diversity analysis by comparing the effects of diets on the jejunum

Values of mean (Diet1/Diet2 means), values of SD (Diet1/Diet2 SD) and *p* for *Chao1* and *PD_whole_tree* indexes considering all pairwise comparisons between CTL, CTS and CMB are shown.

To determine similarities between pairs of microbial communities (α -diversity), a principal component analysis was carried out using all samples belonging to CTL, CTS and CMB diet. The results are presented in Figure 2.11C. No clustering of dietary treatment was identified. This indicates that irrespective of dietary treatment that there was no separation of bacterial communities with diet and confirms that all samples shared a common core set of bacteria in the jejunum. Statistical evaluation confirmed that the difference between dietary groups was not significant ($p > 0.05$).

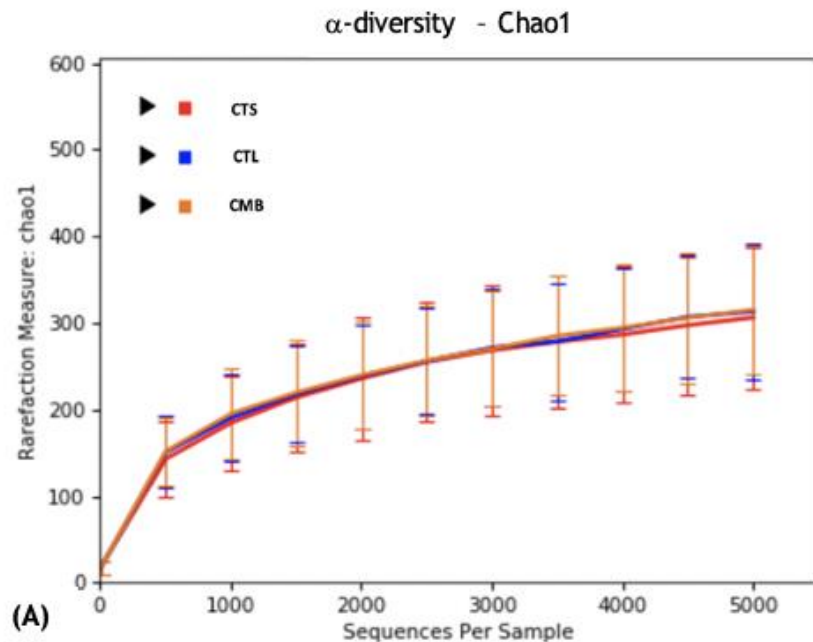

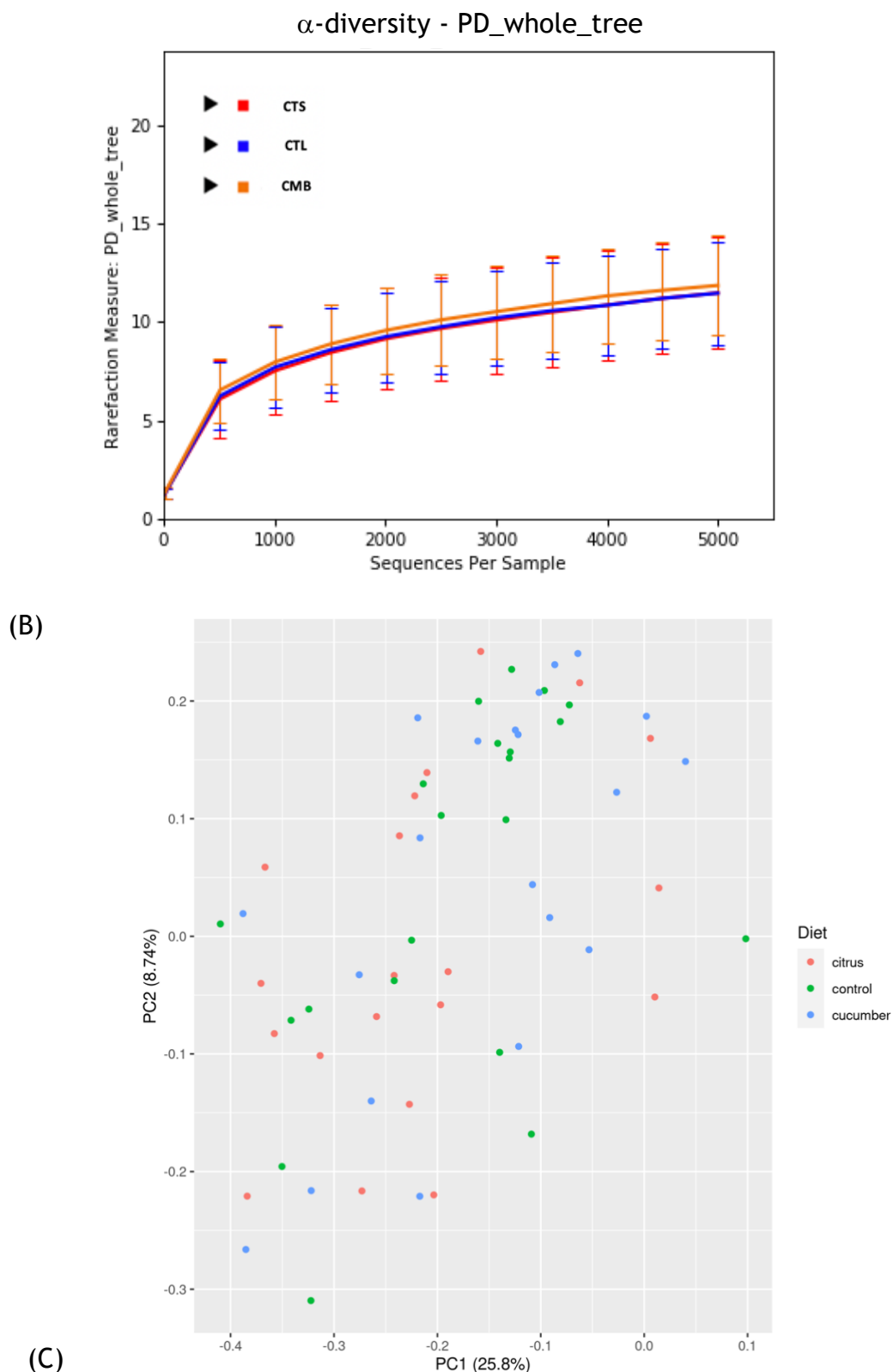
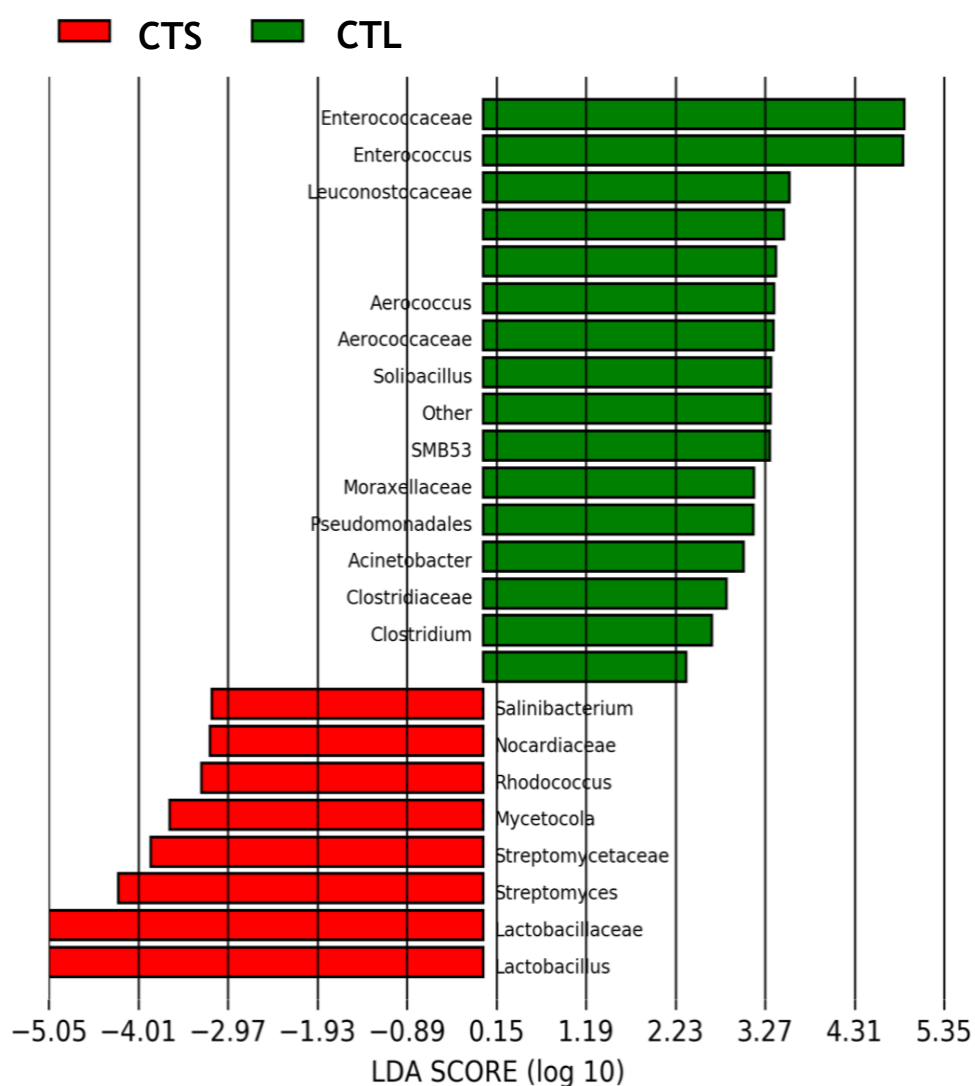

Figure 2.11 Dietary effect on microbiota diversity in the jejunum

Rarefaction curves for jejunum samples (α -diversity) associated with CTS, CMB and CTL diet; the three rarefaction curves follow the same trend and indicate that there are no differences within a given sample, depending on diets (CTL vs CTS vs CMB), in terms of Chao1 (A) and PD_whole_tree (B). PCA of unweighted UniFrac distances (β -diversity) shows no clustering among samples associated with a given diet (C). There is therefore no evidence that the CTS and CMB diets modulate the overall microbiota composition of the jejunum.

LEfSe indicated that CTS diet had a significantly higher relative abundance of the families *Lactobacillaceae* (LDA > -4), *Streptomyetaceae*, *Nocardiaceae* (LDA > -3) and the genus *Lactobacillus*, *Streptomyces* (LDA > -4), *Mycetocola*, *Rhodococcus*, *Salinebacterium* (LDA > -3) compared to CTL diet. It also negatively influenced the abundance of the families *Enterococcaceae* (LDA > 4), *Leuconocasteaceae*, *Aerococcaceae* (LDA > 3), *Clostridiaceae*, *Moraxellaceae* (LDA > -2) and the genus *Enterococcus* (LDA > 4), *Aerococcus*, *Solibacillus* (LDA > 3), *Acinetobacter*, *Clostridium* (LDA > 2) compared to CTL diet (Figure 2.12A). Relative abundance of these bacteria, in CTS and CTL diet, was studied in each sample. Among these bacteria, the relative abundance of *Lactobacillus* (higher abundance) and *Enterococcus* and *Clostridium* (lower abundance) was confirmed in the jejunum of most broilers, fed with CTS diet (Figure 2.12B, C, D).

No differences were discovered at the jejunum level by comparing CMB vs CTL diet.



(A)

Lactobacillus

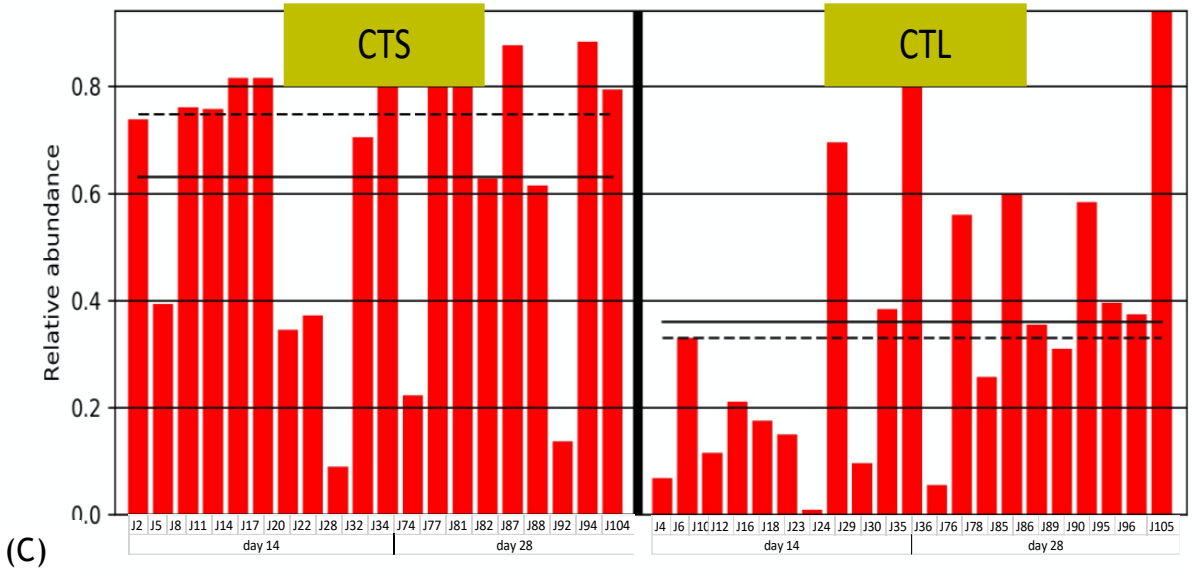

(B)

Enterococcus

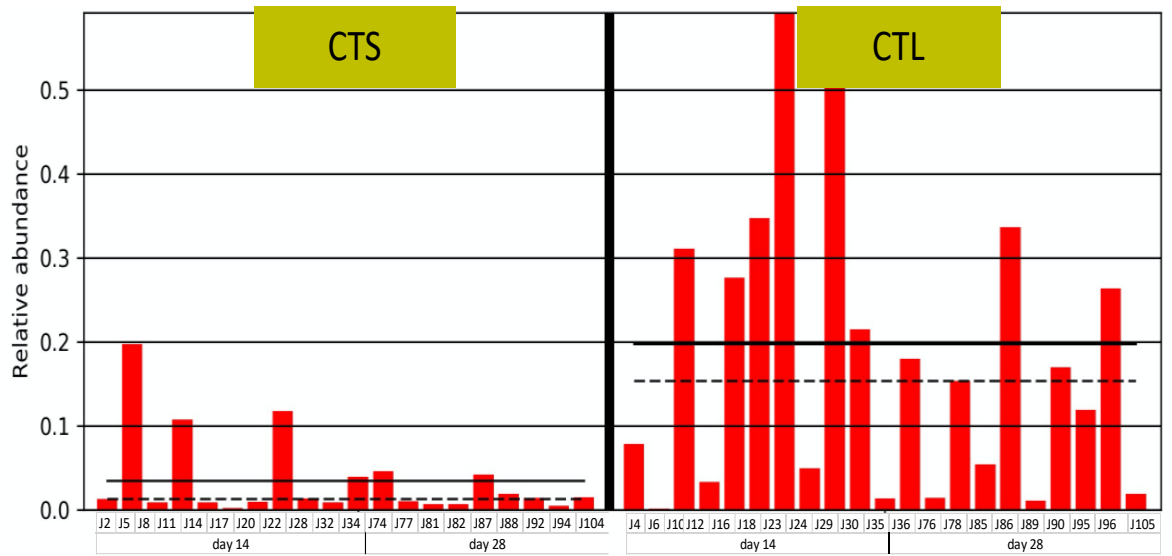

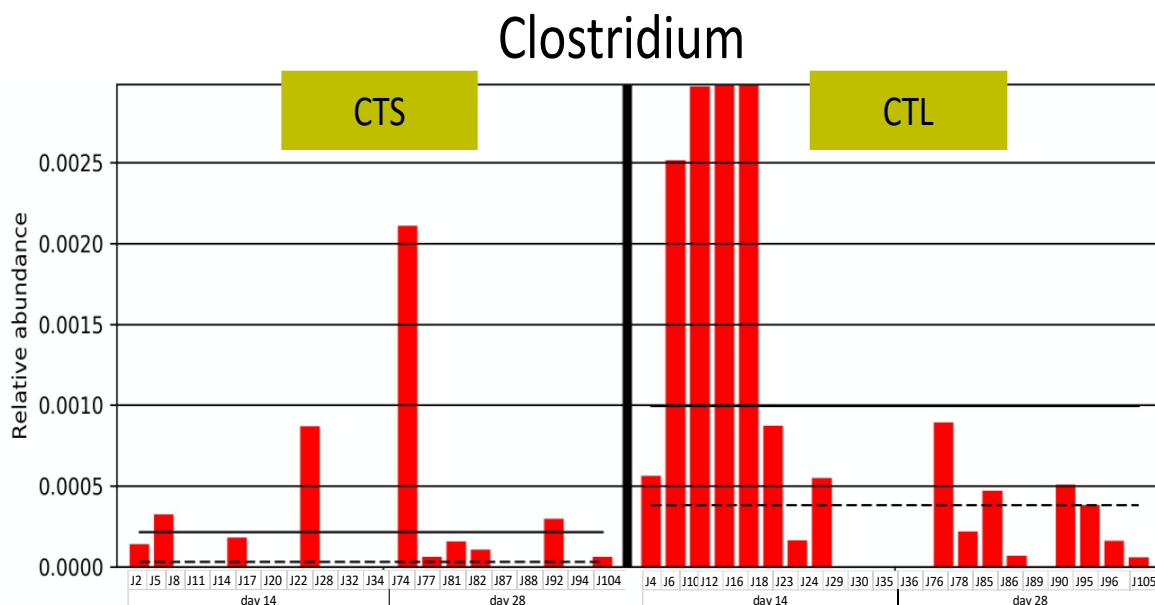

(D)

Figure 2.12 LEfSe - bacteria modulated by CTS diet in the jejunum

Linear discriminant analysis (LDA) effect size (LEfSe) identifies specific phylotypes which are significantly influenced by CTS diet ($p < 0.05$) compared to CTL basal diet. The LDA score value +/- n indicates the difference in abundance of specific bacteria in CTS vs CTL group; an higher +/- LDA score indicate a bigger difference in the abundance of that bacteria in the specific dietary group (A). The three histograms indicate the relative abundance of *Lactobacillus* (B), *Enterococcus* (C) and *Clostridium* (D) in each sample of the CTS vs CTL diets. The higher relative abundance of *Lactobacillus* and lower of *Enterococcus* and *Clostridium* in the jejunum of most broilers, fed with CTS diet is confirmed.

2.4.6 Dietary effects on the caecal microbiota

α -diversity indices for CTL, CTS and CMB diet comparisons, indicated that there was no significant difference in the caeca based on different diet administration (Table 2.4). In the Figure 2.13A and B rarefaction curves generated from α -diversity indices (Chao1 and PD_whole_tree) follow the same trend and they overlap each other to indicate that diets (CTL vs CTS vs CMB) did not differ in terms of within samples bacterial diversity.

α -diversity index	Diet 1	Diet 2	Diet 1 mean	SD	Diet 2 mean	SD	<i>p</i>
<i>Chao1</i>	CTL	CTS	446.94	± 60.16	457.06	± 79.12	~1.00
	CTL	CMB	446.94	± 60.16	444.53	± 70.10	~1.00
	CTS	CMB	457.06	± 79.12	444.53	± 70.10	~1.00
<i>PD_whole_tree</i>	CTL	CTS	11.47	± 2.59	11.48	± 2.83	~1.00
	CTL	CMB	11.47	± 2.59	11.86	± 2.52	~1.00
	CTS	CMB	11.48	± 2.83	11.86	± 2.52	~1.00

Table 2.4 Data of α -diversity indices by comparing the effects of diets on the caeca

Values of mean (Diet1/Diet2 means), values of SD (Diet1/Diet2 SD) and *p* for Chao1 and PD_whole_tree indices considering all pairwise comparisons between CTL, CTS and CMB are shown.

Unweighted UniFrac PCoA plots, generated by β -diversity analysis, demonstrated that caeca samples did not separate based on dietary treatment. The statistical evaluation confirmed that the difference was not significant ($p > 0.05$) (Figure 2.13 C).

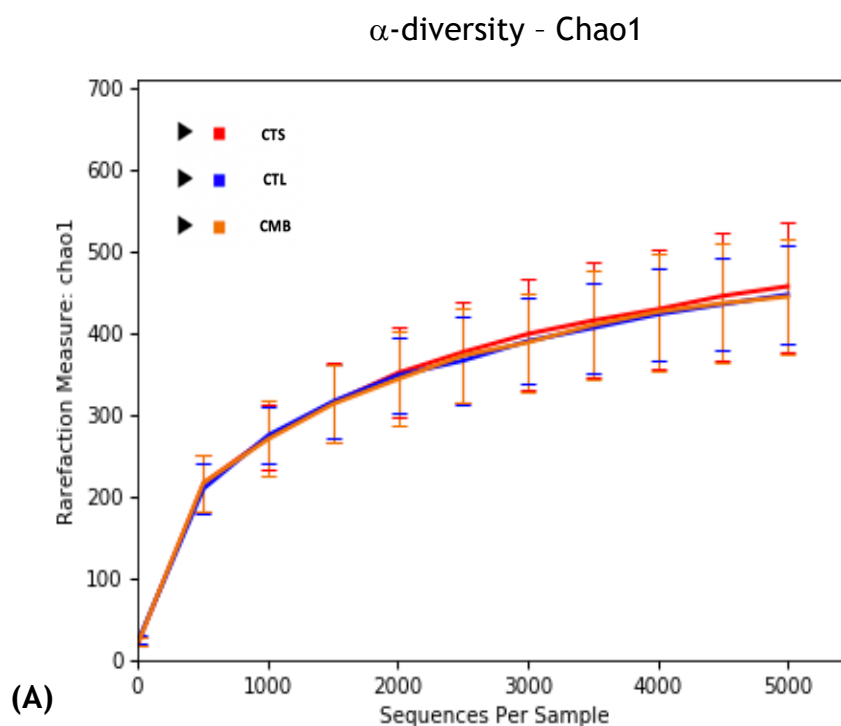

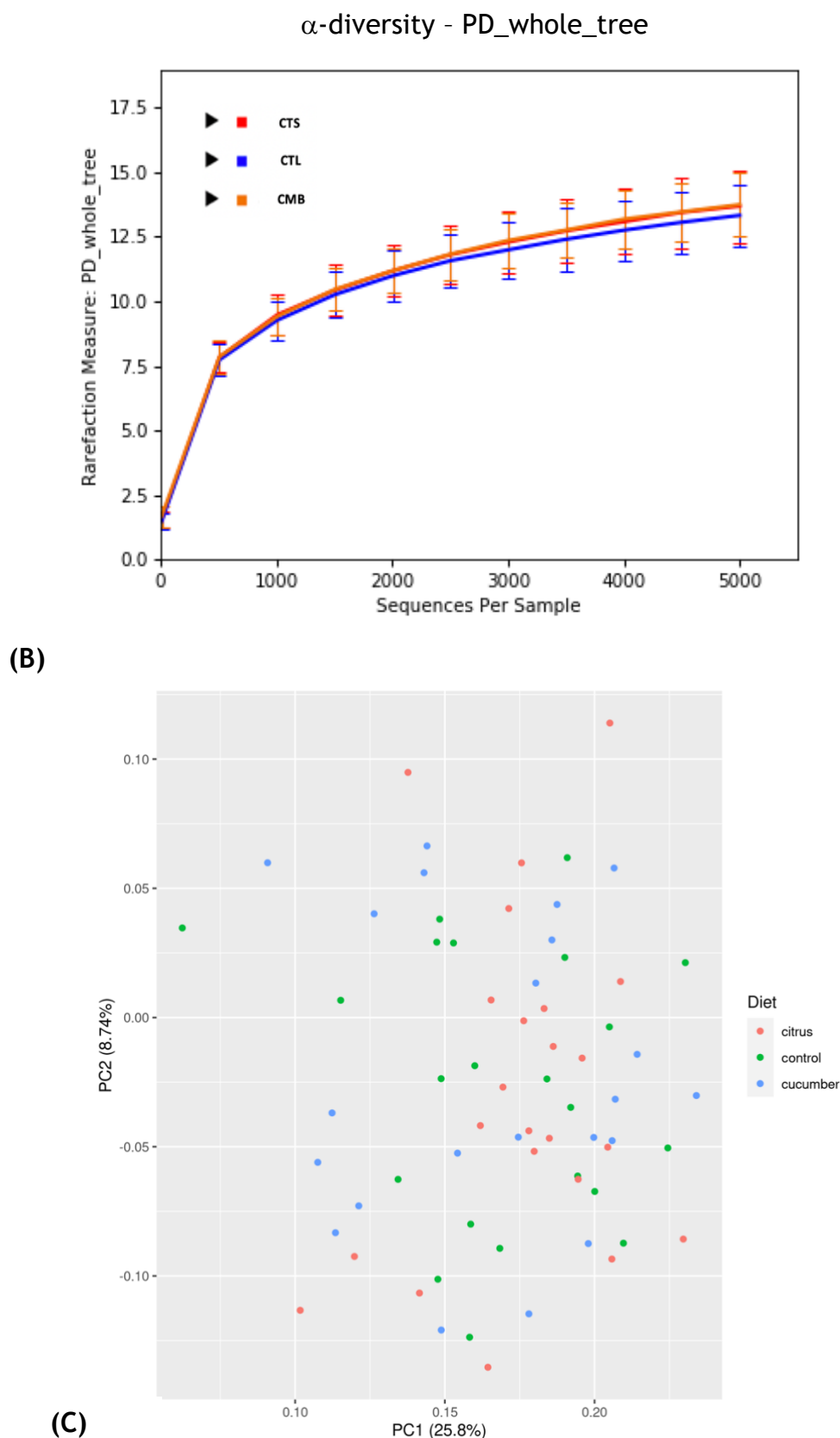

Figure 2.13 Dietary effect on microbiota diversity in the caeca

Rarefaction curves (α -diversity) indicate there are no differences within a given sample depending on experimental diets (CTS and CMB), based on Chao1 (A) and PD_whole_tree (B). β -diversity demonstrates through Principal component analysis (PCA) of unweighted UniFrac distances, that diets (CTS and CMB) don't modulate the overall microbiome composition. No clustering is formed based on the diets (C).

Differentially abundant taxa were identified using LEfSe analysis. This revealed that the abundance of the family *Microbacteriaceae* (LDA > -2) and the genus *Blautia* (LDA > -4), increased with the CTS diet compared to the CTL diet while the abundance of three other families *Enterococcaceae* (LDA > 3), *Peptostreptocaccaceae*, *Rhizobiaceae* (LDA > 2) decreased. Three genera namely *Enterococcus* (LDA > 3), *Coprobacillus* and *Agrobacterium* (LDA > 2) also decreased in the CTS diet compared to the CTL diet (Figure 2.14 A).

Figure 2.14 B and C shows the histogram comparing of the relative abundance of *Blautia* and *Enterococcus* in the CTS and CTL samples. *Blautia* was confirmed to be significantly higher in the CTS diet while genus *Enterococcus* was found significantly lower in CTS diet.

On the other hand, CMB was found to mainly influence the order of *Bacillales* and *Rickettsiales* (LDA > 3), families of *Planococcaceae*, *Bacillaceae* (LDA > 3) and genus *Bacillus* and *Adercreutzia* (LDA > 2) by increasing their abundance while CTL showed higher abundance of the order *Bacteroides* and the respective phylum, family, and genus (LDA > -4) (Figure 2.15 A). The relative abundance of these bacteria per each sample in the two dietary groups (CMB and CTL) was studied; *Bacillus* (Figure 2.15 B) and the respective phylum and family were confirmed to be more influenced by CMB diet compared to CTL diet.

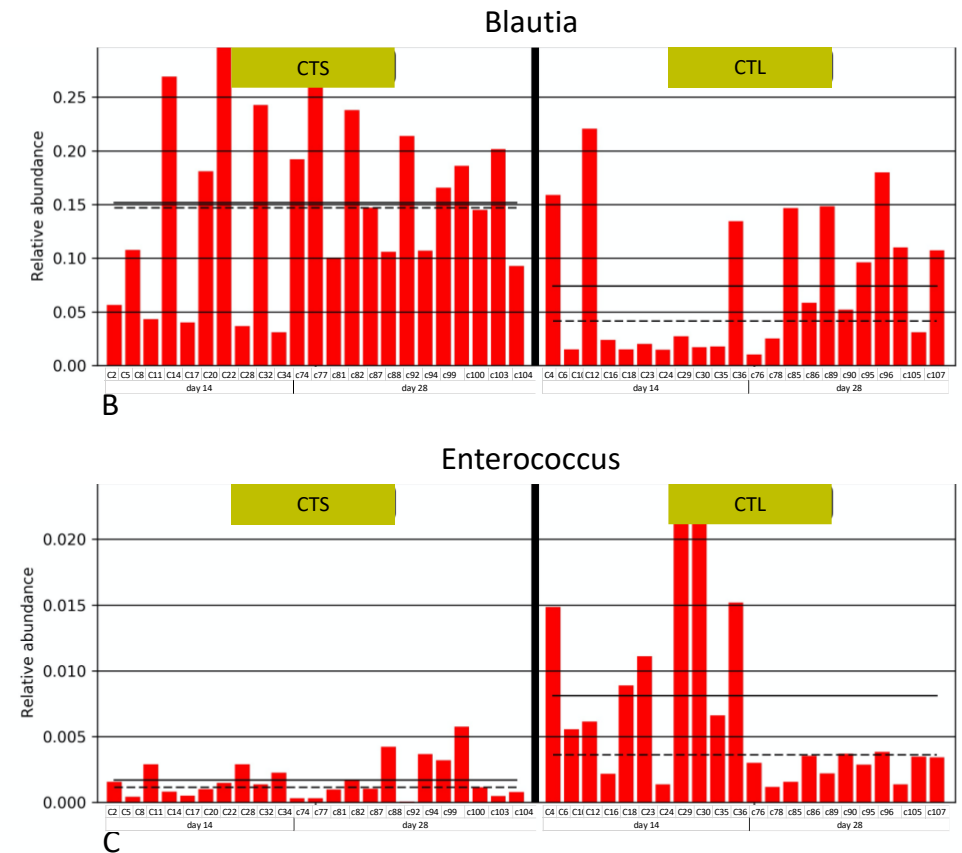
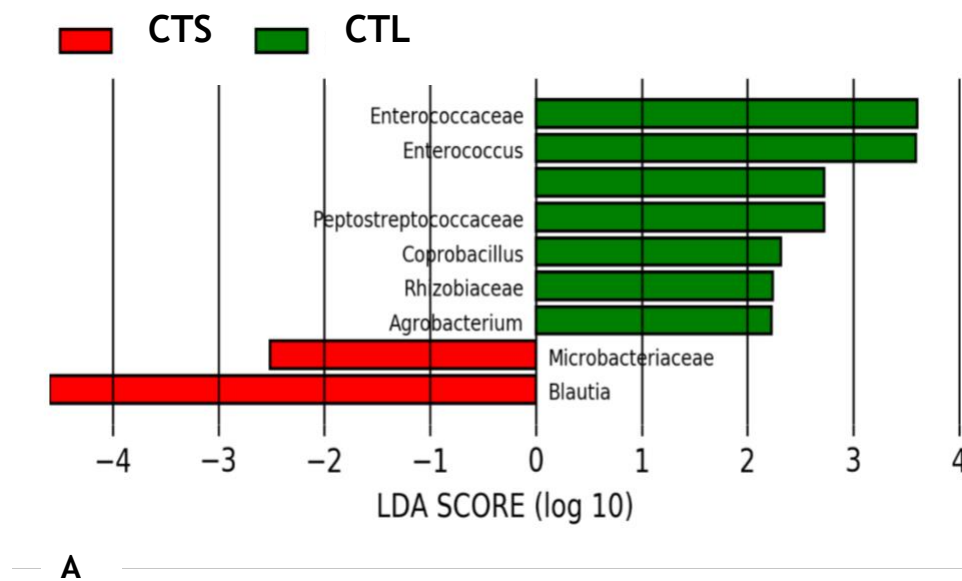

Figure 2.14 LefSe - bacteria modulated by CTS in the caeca

LefSe identified specific phlotypes which were significantly influenced by CTS and CTL diets ($p < 0.05$); the LDA score value +/- n indicates the difference in abundance of specific bacteria belonging to one of the two dietary groups. A higher +/- LDA score indicate a bigger difference in their abundance (**A**). The histograms verify that the relative abundance of *Blautia* (**B**) and *Enterococcus* (**C**) which LefSe indicates to be influenced by CTS diet. The relative higher abundance of *Blautia* and lower abundance of *Enterococcus* is confirmed in the caeca of most broilers, fed with CTS diet.

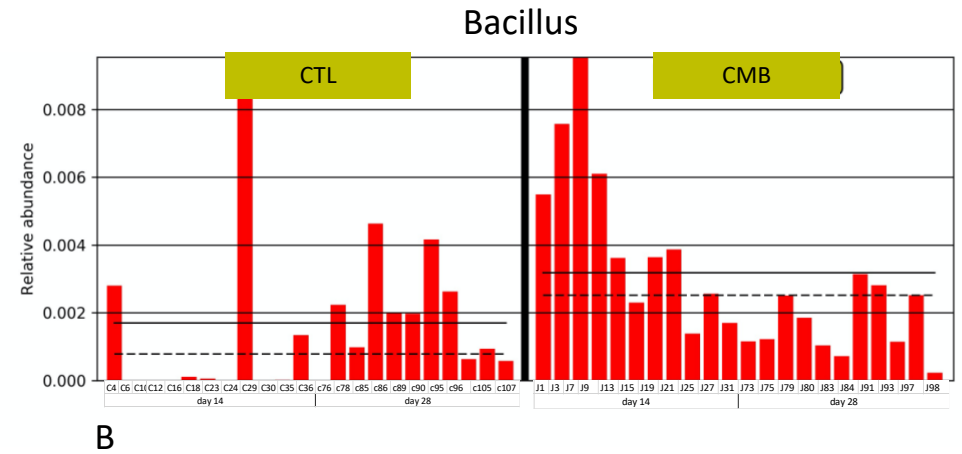
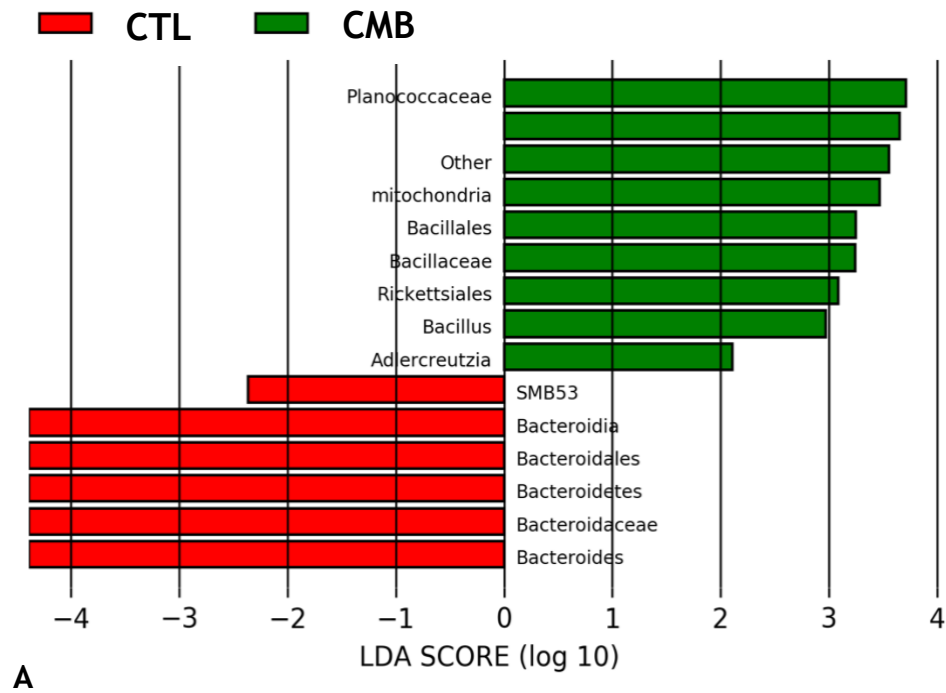

Figure 2.15 LefSe – bacteria modulated by CMB in the caeca

LefSe indicates, through LDA scores, the difference in abundance of specific bacteria belonging to CTL vs CMB groups ($p < 0.05$) (A). The histogram (B) shows the relative abundance of *Bacillus* in each broiler fed with CMB and CTL diet. Its relative abundance is confirmed to be higher in broilers fed with CMB diet.

2.4.7 Comparison between jejunal and caecal microbiota

Table 2.5 shows that there was a significant difference in the richness and phylogenetic diversity between the jejunal and caecal samples ($p = 0.001$). The two clearly separating rarefaction curves generated by Chao1 (Figure 2.16 A) and PD_whole_tree (Figure 2.16 B) indexes confirm that the gut site significantly affected the species richness and phylogenetic diversity of the microbiota. Moreover, the number of observed OTUs in the caecal samples was found to be higher, suggesting that the microbiota of the caeca was more diversified than that of the jejunum.

<i>α-diversity index</i>	<i>Tissue1</i>	<i>Tissue2</i>	<i>Tissue1mean</i>	<i>SD</i>	<i>Tissue2mean</i>	<i>SD</i>	<i>p</i>
Chao1	caeca	jejunum	468.01	± 76.41	301.62	± 81.85	0.001
PD_whole_tree	caeca	jejunum	13.50	± 1.20	9.54	± 2.24	0.001

Table 2.5 Data of α -diversity analysis by comparing tissues (jejunum vs caeca)

Values of mean (Tissue1/Tissue2 means), values of SD (Tissue1/Tissue2 SD) and p for Chao1 and PD_whole_tree indexes comparing jejunum vs caeca samples are shown. The difference between jejunum and caeca is found significant ($p = 0.001$).

β -diversity analysis of unweighted PCoA plots showed clustering when the two sites (caeca and jejunum) were compared (Figure 2.16 C). Statistical evaluation confirmed a significant difference in the overall microbial diversity based on gut location ($p < 0.05$).

caeca samples clustered more compactly compared to jejunum samples, indicating less variation in microbiota composition in the caeca site

α -diversity - Chao1

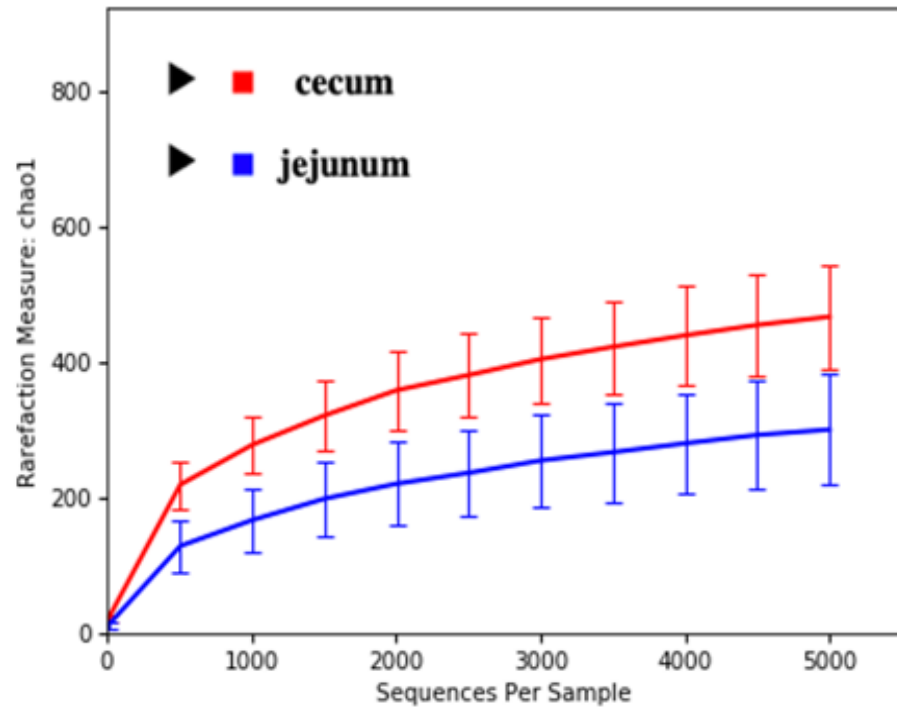

(A)

α -diversity - PD_whole_tree

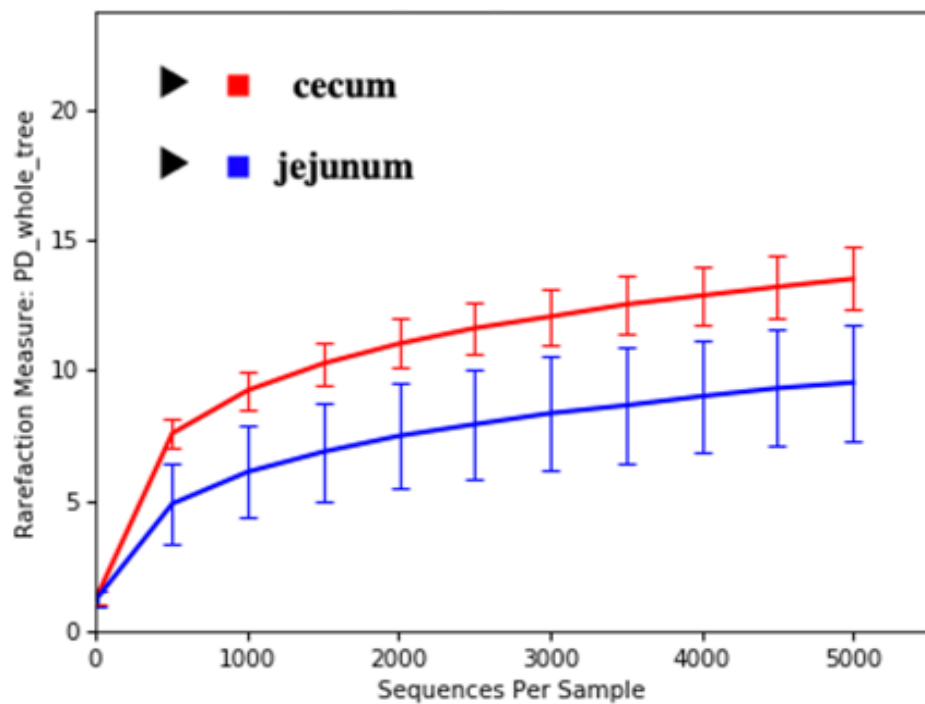

(B)

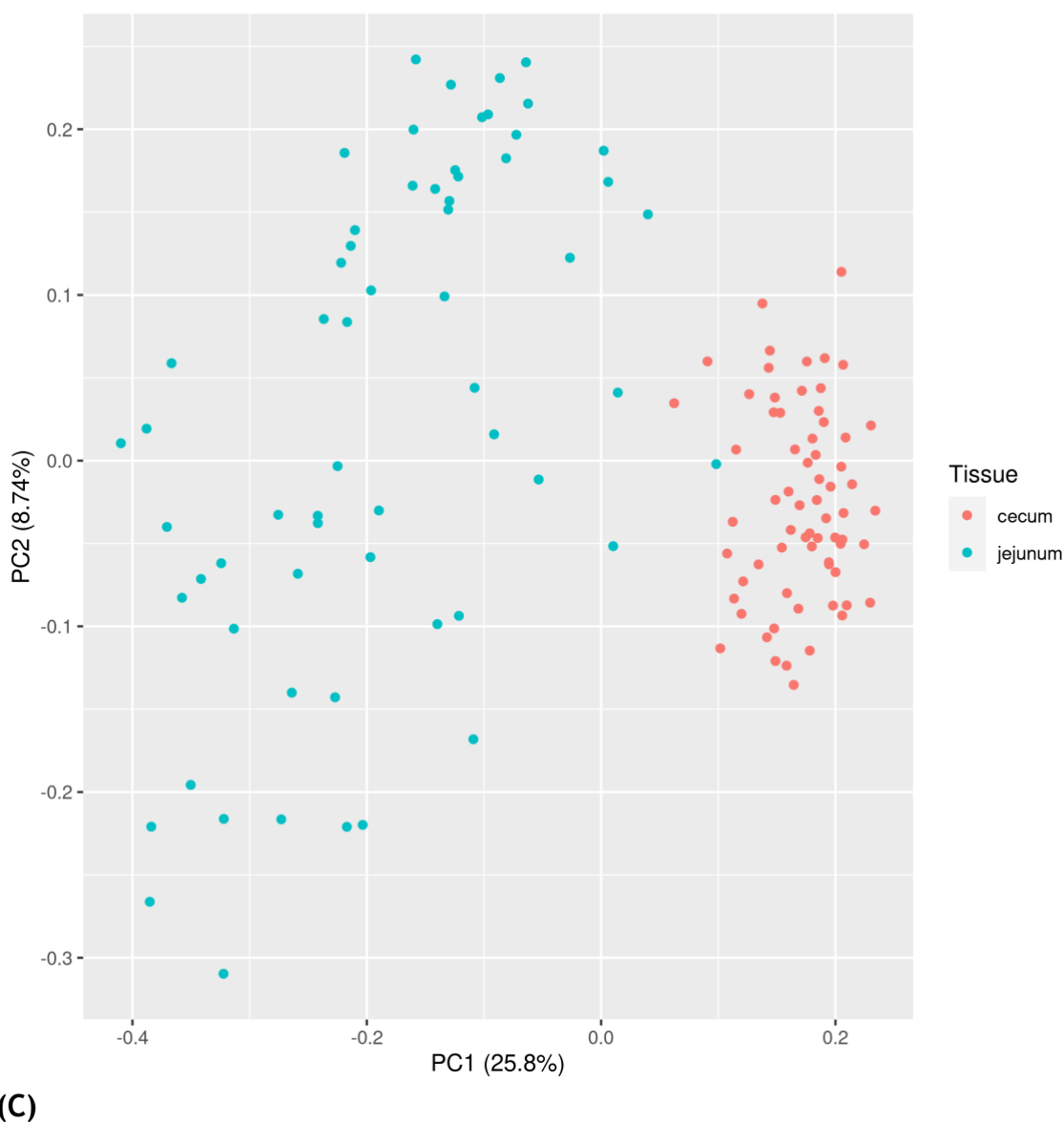

Figure 2.16 Tissue effect (jejunum vs caeca) on β -diversity

α -diversity rarefaction curves of jejunum vs caeca indicate that there is a significant difference depending on the gut site (caeca vs jejunum), based on Chao1 (A) and PD_whole_tree (B). β -diversity demonstrates through Principal component analysis (PCoA) of unweighted UniFrac distances, that the overall microbiota population is modulated by gut site (C).

LEfSe results analysis showed that more than 100 bacteria belonging to different taxonomic levels were differentially abundant between the jejunum and caeca microbiota composition. The following observations were made on those which showed a consistent relative abundance distribution among samples of the gut site. At phylum level, multiple bacterial strains belonging to *Proteobacteria*, and *Cyanobacteria* were predominant in the jejunum while the caeca mostly inhabited by some strains of *Bacteroidetes* and *Verrucomicrobia*. At family level, jejunum showed higher abundance of *Lactobacillaceae* (LDA > 4), *Enterococcaceae* (LDA > 3), *Aerrococcaceae*, *Planococcaceae*, *Corynebacteriaceae* (LDA > 2), *Streptomycetaceae*, *Nocardiaceae*, *Microbacteriaceae*, *Micrococcaceae* (LDA > 1),

while *Bacteroidaceae* (LDA > -3) and *Coriobacteriaceae* (LDA > -2) were more dominant in the caeca.

At genus level, the jejunum displayed a significantly higher abundance of *Lactobacillus*, *Enterococcus*, *Streptococcus* and *Lactococcus* (LDA > 4) compared to the caeca while *Ruminococcus* and *Blautia* (LDA > -4) were more abundant in the caeca. The Cladogram (Figure 2.17) generated from LEfSe allows the visualization of the bacteria, from level 2 (phylum) to level 6 (genus), which were modulated by the two gut sites. Biomarker taxa are heightened by coloured circles and shaded areas. Each circle's diameter is relative to the abundance of taxa in each microbial community from phylum to genus level. Chloroplast was found among the list of bacteria and data were filtered again but no difference was encountered in the main core of bacteria at the caecum and jejunum level.

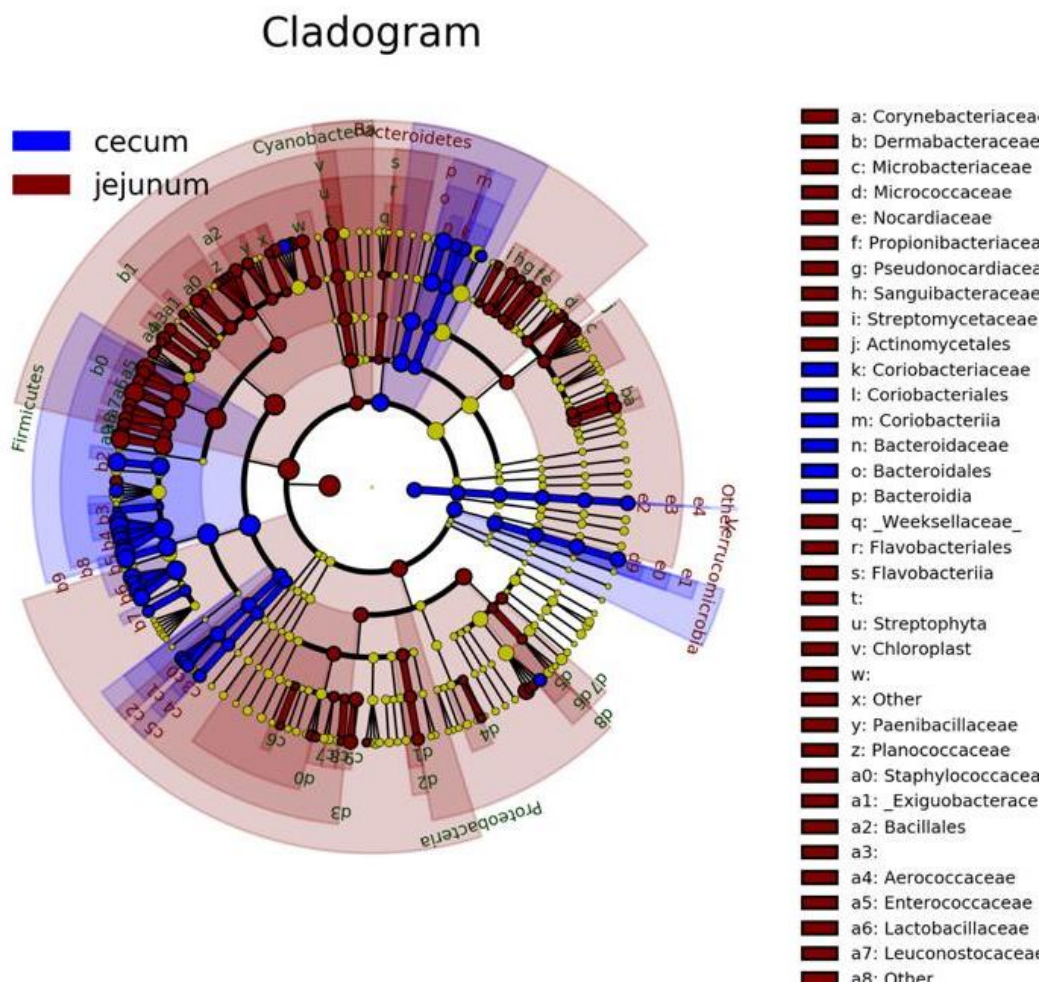

Figure 2.17 LEfSe – bacterial differences between tissues (jejunum vs caeca)

LEfSe Cladogram indicates the significant bacteria from phylum to genus levels, which are modulated by the two tissues ($p < 0.05$). Biomarker taxa are heightened by shaded areas and coloured circles. The list of bacteria in brown represents the ones which are significantly modulated by jejunum while blue indicates the ones mostly modulated by the caeca site.

2.4.8 Effect of bird age on the jejunal microbiota (d14 and d28)

The same workflow, used to explore differences based on dietary treatments and tissue, was applied to investigate the influence of bird age on the jejunal and caecal microbiota.

In the jejunum, no significant differences were found comparing the α -diversity indices calculated at 14 and 28d ($p > 0.05$) (Table 2.6). Rarefaction curves, generated by Chao1 and PD_whole tree, can be seen to approach a plateau and overlap, which indicate good sequencing depth to cover all the OTUs and no difference in terms of within samples bacterial diversity based on bird age (14 vs 28d old) (Figure 2.18A, B).

<i>α-diversity index</i>	<i>Age 1</i>	<i>Age 2</i>	<i>Age 1 mean</i>	<i>SD</i>	<i>Age 2 mean</i>	<i>SD</i>	<i>p</i>
<i>Chao1</i>	14	28	238.36	± 50.50	237.38	± 57.54	0.94
<i>PD_whole_tree</i>	14	28	7.81	± 1.67	8.12	± 1.58	0.47

Table 2.6 Data of α -diversity analysis by comparing birds ages (14 vs 28d old) in jejunum samples

Values of mean (Age1/Age2 means), values of SD (Age1/Age2 SD) and p for Chao1 and PD_whole_tree index comparing day 14 vs 28 are shown. The difference identified is not significant.

β -diversity of unweighted PCoA plots was used to identify differences among samples of the two-bird age (14 vs 28d old). In the unweighted PCoA plot, bird age had a significant impact on the jejunal microbiota composition ($p < 0.05$): samples formed two slightly separated clusters (Figure 2.18C).

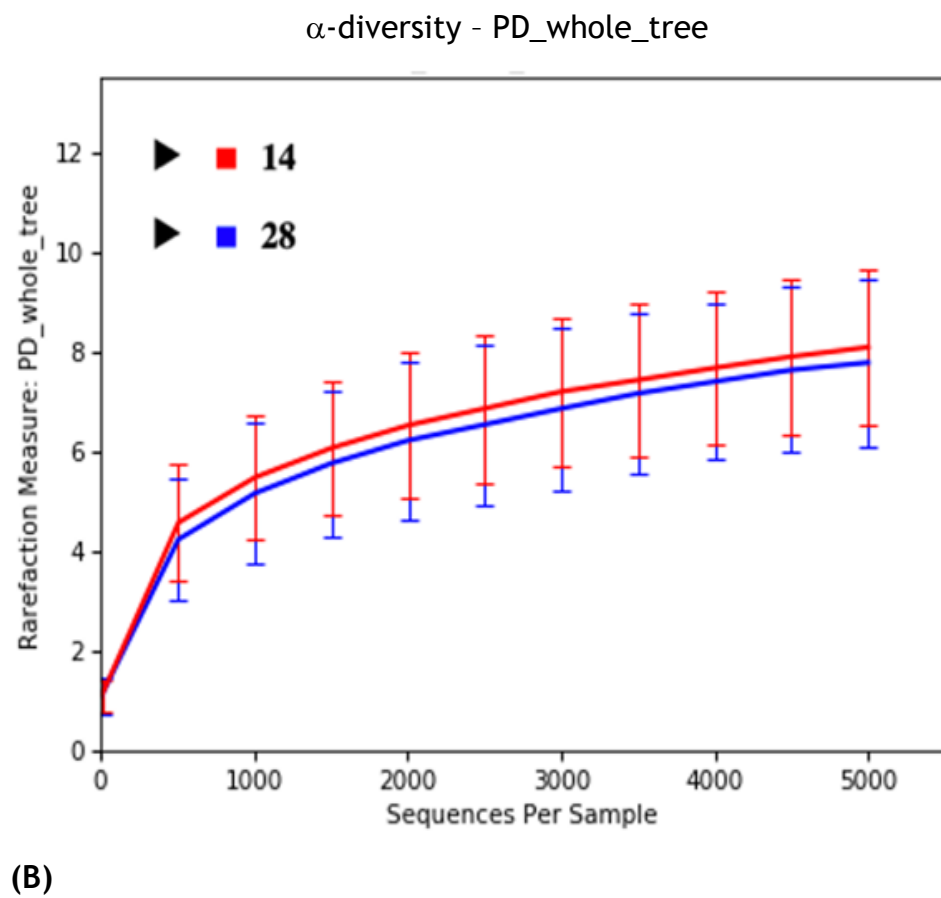
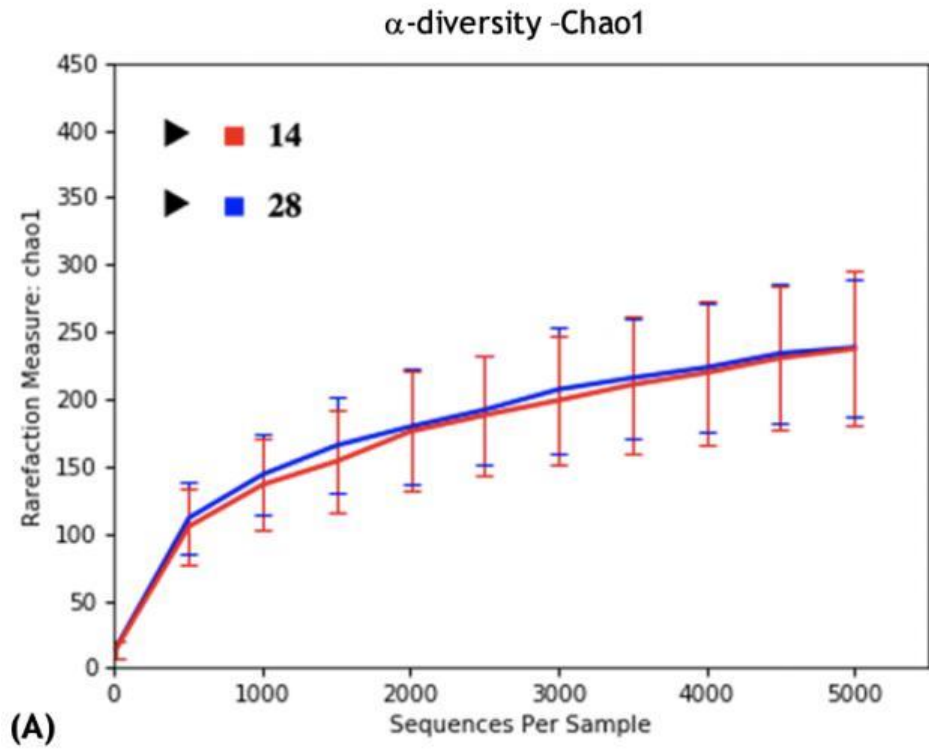

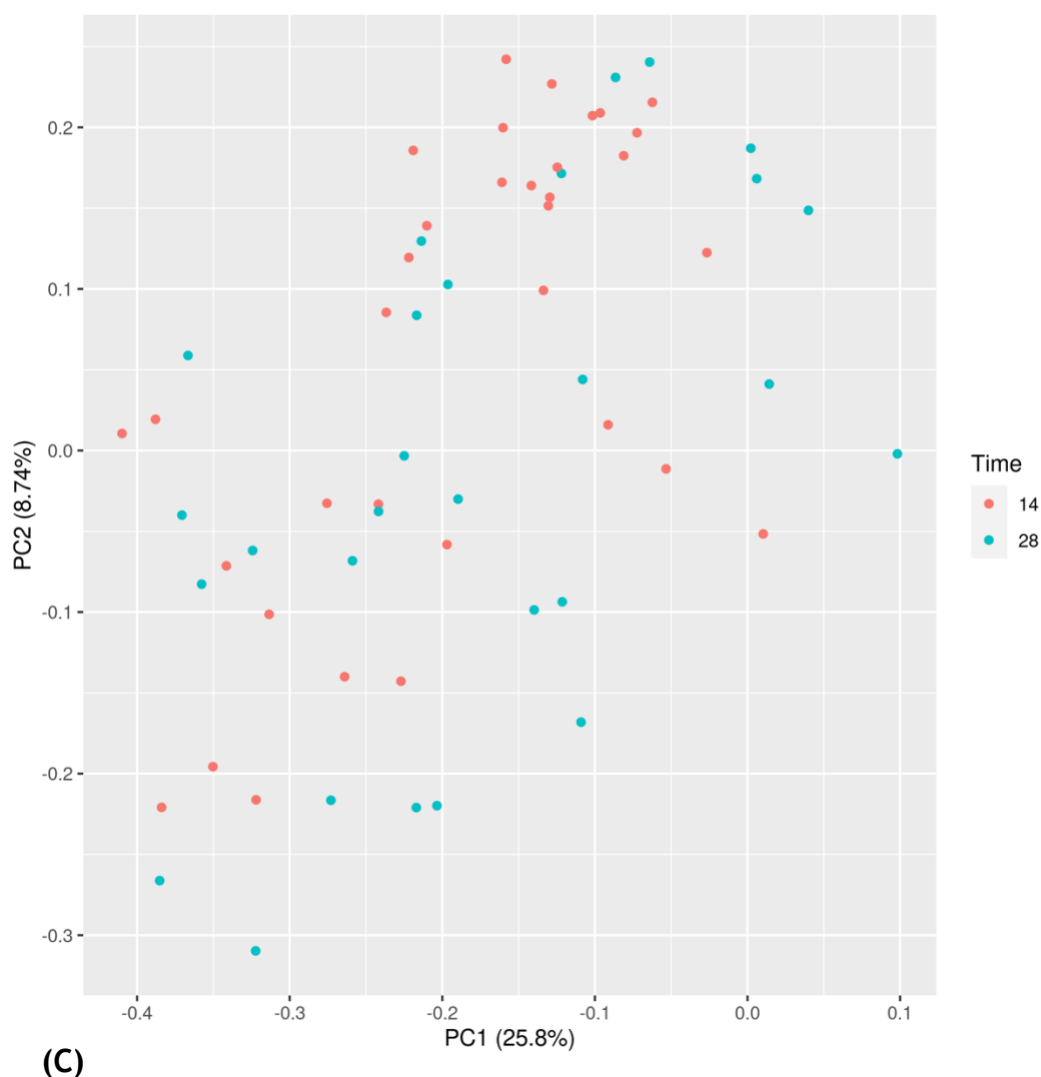

Figure 2.18 Bird age effect on diversity in the jejunal microbiota

α -diversity rarefaction curves of samples at 14 and 28d of bird age are investigated with both Chao1 (A) and PD_whole_tree (B) indexes. No within samples microbial differences are identified based on bird's age. β -diversity (C) forms, through Principal component analysis (PCoA) of unweighted UniFrac distances, two clusters at day 14 and day 28. Bird age therefore had a slight impact on the overall microbiota composition of the jejunum.

LEfSe analysis revealed a list of differentially abundant taxa between age groups for the jejunum. The following observations were made on those which showed a consistent relative abundance distribution among samples of the same age group. At 14d of age there was significantly higher abundances of the order *Rickettsiales* (LDA > -2) the families *Microbacteriaceae*, *Nocardiaceae* (LDA > -2) and genus *Bifidobacterium* (LDA > -3) whereas at 28d old, the families *Streptococcaceae* (LDA > 4), *Aerococcaceae* (LDA > 3) and genus *Lactococcus* (LDA > 4) were found to be significantly increased (Figure 2.19).

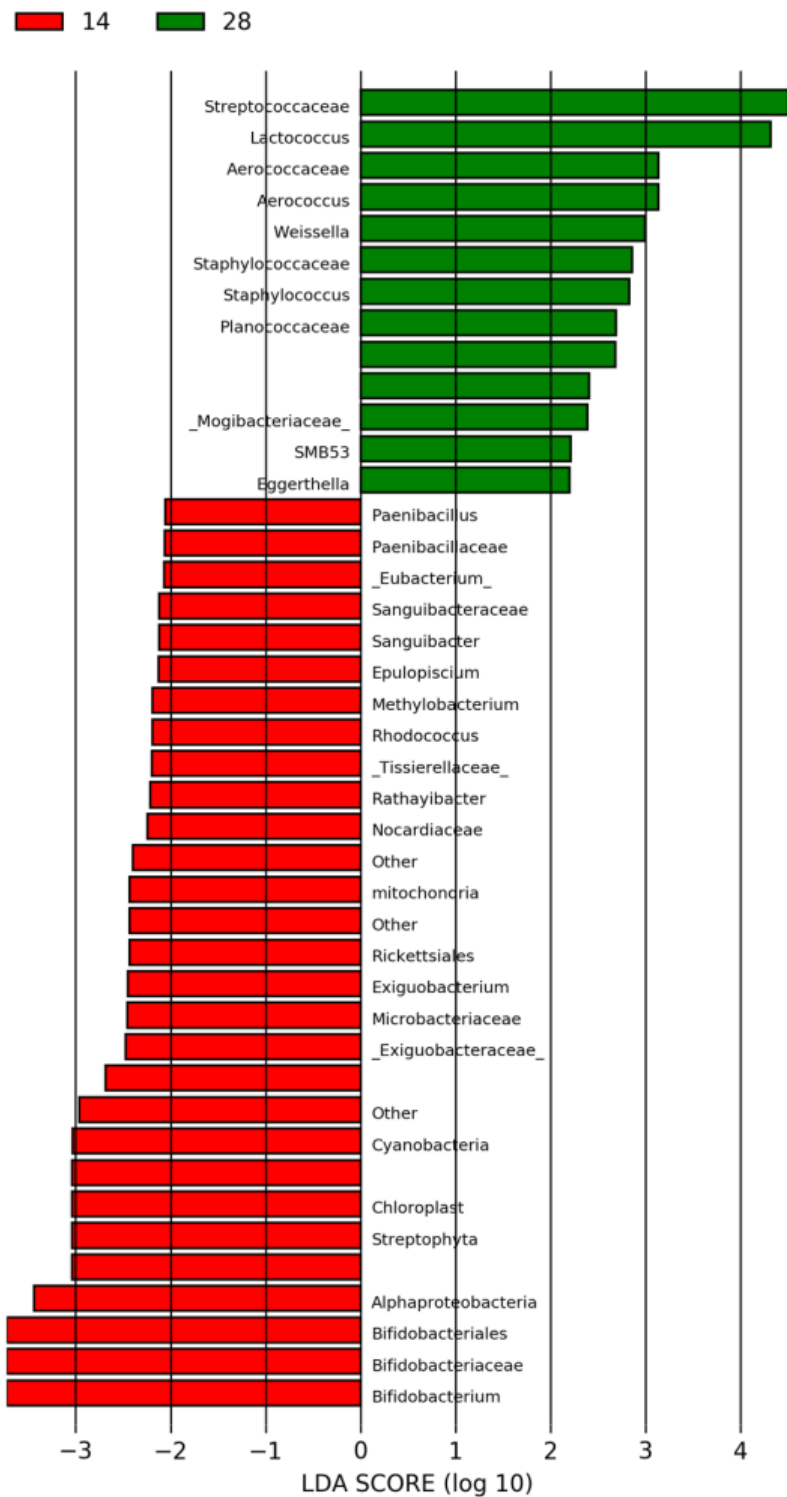

Figure 2.19 LefSe – bacteria modulated by bird age in the jejunum

LefSe showed the entire list of bacteria which are significantly modulated by bird's age at 14 and 28d old ($p < 0.05$). LDA scores indicates the higher or lower significance of the relative abundance difference of the bacteria in the two bird age groups.

2.4.9 Effect of bird age on the caecal microbiota (d14 and d28)

α -diversity indices are compared in Table 2.7 for the caecal microbiota at day 14 and day 28. Relatively small differences were found for both the Chao1 and the PD whole tree index ($p < 0.05$). Rarefaction curves, representing these data, are shown in the Figure 2.20A, B.

α -diversity index	Age 1	Age 2	Age 1 mean	SD	Age 2 mean	SD	p
<i>Chao1</i>	14	28	367.99 ±	96.61	410.39 ±	128.39	0.05
<i>PD_whole_tree</i>	14	28	2.22 ±	2.36	12.18 ±	2.97	0.02

Table 2.7 Data of α -diversity analysis by comparing birds age (14 vs 28d old) in caeca samples

Values of mean (Diet1/Diet2 means), values of SD (Diet1/Diet2 SD) and p for Chao1 and PD_whole_tree index are compared for day 14 and day 28.

In the unweighted PCoA plot, generated from β -diversity analysis, samples formed two clusters according to bird age (Figure 2.20C). This confirmed that the microbiota composition of the caeca was influenced by age ($p < 0.05$).

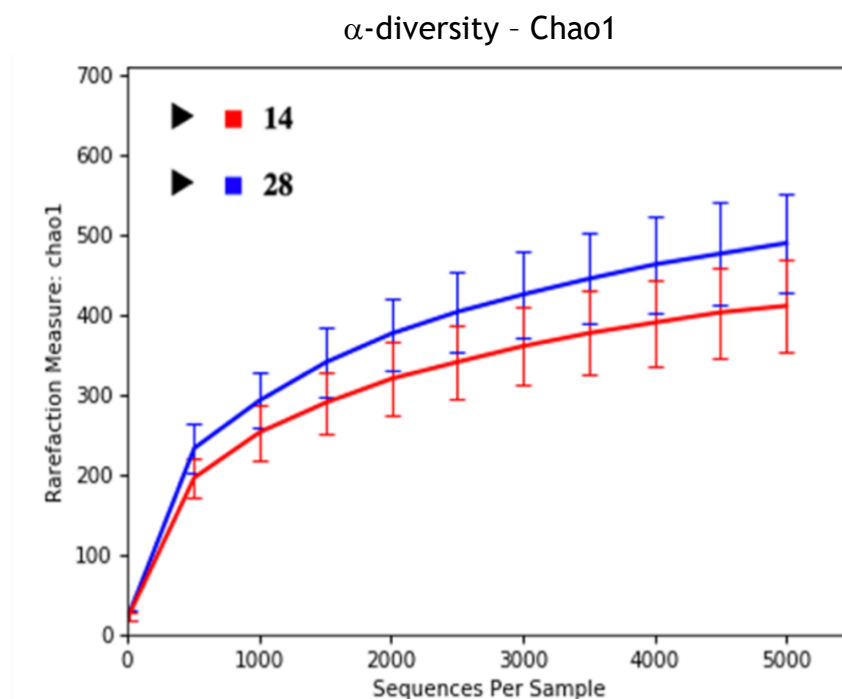

(A)

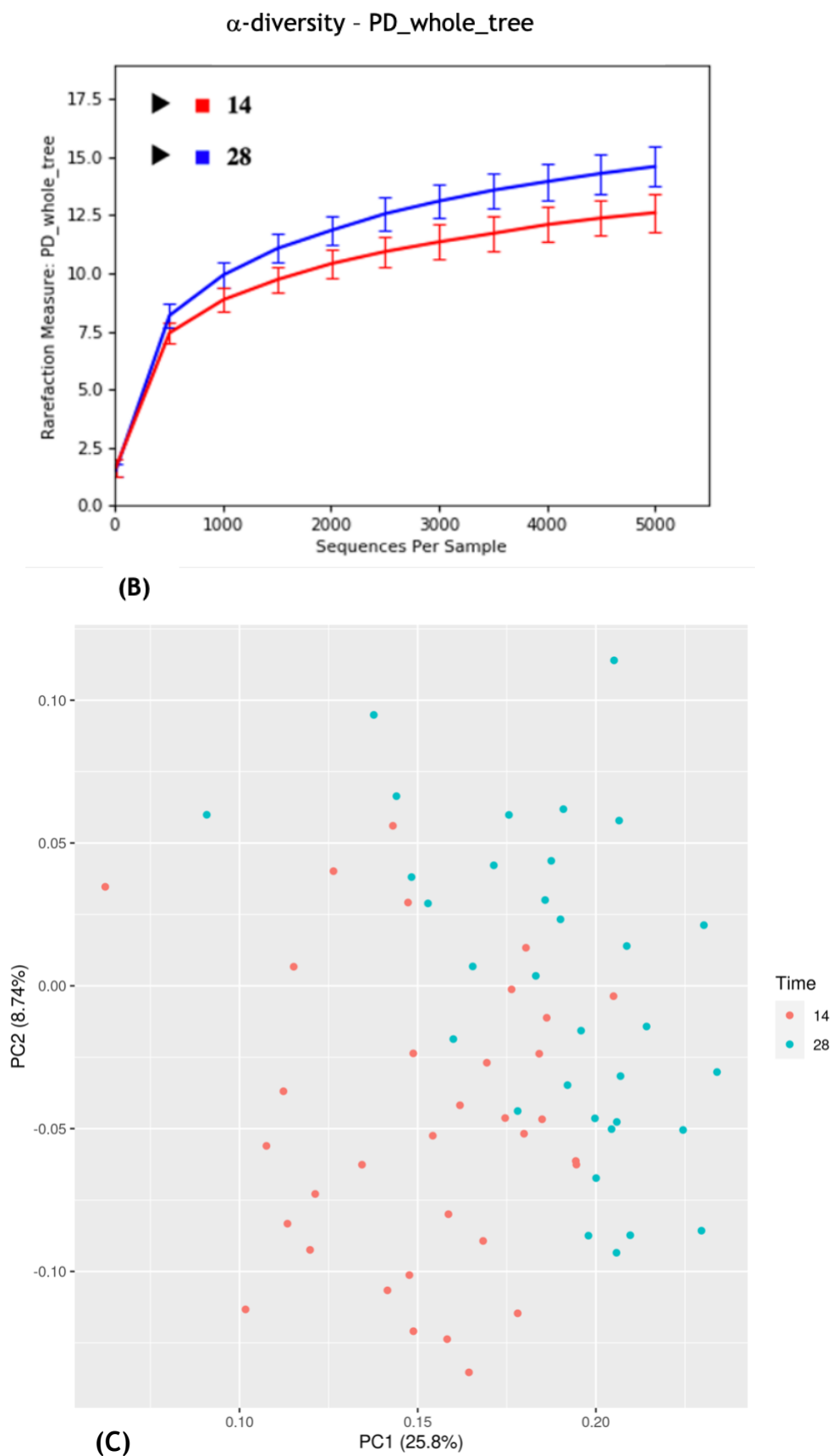

Figure 2.20 Bird age effect on diversity in the caecal microbiota

α -diversity rarefaction curves at 14 and 28d of caeca samples were investigated with both Chao1 (A) and PD whole tree (B) indexes. Significant differences ($p < 0.05$) in term of species richness and phylogenetic diversity can be observed. β -diversity analysis shows clustering at d14 and d28 (C); bird age therefore has an effect on the overall microbial community of the caeca.

LEfSe analysis provided the list of biomarker bacteria presented in Figure 2.21. Only the ones which showed a consistent relative abundance distribution among samples were considered further; a significantly higher abundance of bacteria belonging to the phylum of *Actinobacteria* and families of *Bifidobacteriaceae*, *Enterobacteriaceae* and *Enterococcaceae* at age 14d was confirmed.

At 28d of age, bacteria of the phylum *Clostridia* and *Firmicutes*, the families *Ruminococcaceae*, *Planococcaceae*, *Staphylococcaceae*, *Leuconostocaceae* and the genus *Blautia* were confirmed to increase.

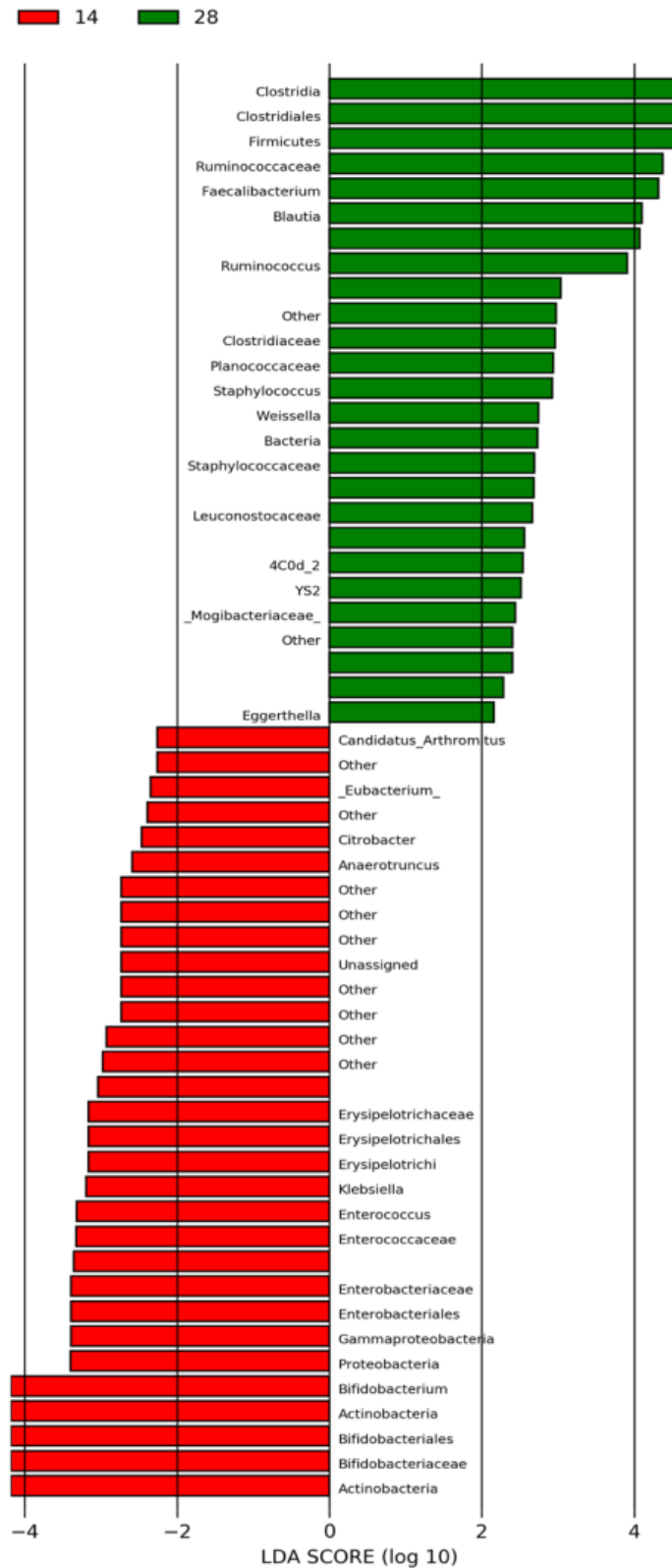

Figure 2.21 LefSe – bacteria modulated by bird age in the caeca

LefSe indicates the list of bacteria which are significantly modulated by bird age at 14 and 28d old ($p < 0.05$). the LDA scores indicate the difference in abundance of specific bacteria belonging to birds of 14 or 28d.

2.5 Discussion

In this chapter, samples from the *in vivo* trial, performed at the Glasgow University facilities, were used to evaluate the gut health and growth performance of broilers based on dietary administration (CTL, CTS and CMB). Gut samples of 14- and 28-day old birds were taken post sacrifice and used to study the effects of dietary supplementation on jejunal and caecal microbiota composition and morphometric measurements (jejunum - villus length, epithelium height and crypt depth) of broilers while data on BW, FI and FCR at day 0,7,14,21,28d old was used to evaluate their growth performance.

Effects of dietary treatments on the intestinal microbiota

In this study high throughput 16SrRNA gene sequencing was used to monitor the jejunum and caecal microbiota of individual broiler chickens fed a control diet (CTL) or the same diet supplemented with a novel plant extract (CTS or CMB) over 4-week production cycle. CTS has previously been shown to have beneficial effects on broiler performance in field trials (Abbasi et al., 2015) and in other monogastric animals (Cui et al., 2021; Leiva et al., 2000). CMB supplemented diets have been shown to have positive effects on gut health in pig (NuScience company trial) and there is growing interest in their use in the diets of poultry (Mandey et al., 2020) (NuScience company trial). In some cases such modulation can be used as an effective tool for the control of potentially pathogenic coliforms and *C. perfringens* (Vidanarachchi et al., 2010). However, data gained from other studies suggests that the overall microbiota bacterial population is most likely to be affected by gut site or age rather than treatment or diet (Ballou et al., 2016). The resultant effect also depends on the type of manipulation which is being administered; in trials where AGPs are used for example, the total bacterial component of the microbiota was significantly modulated (Díaz et al., 2018; Pourabedin et al., 2015). Likewise when broilers are challenged with endotoxins, such as LPS, the total microbiota was found to be strongly modulated (Lucke et al., 2018). In the current work specific bacterial strains were found to be modulated and this has been observed in other trials where novel plant extracts are used (Yu et al., 2019). According to Ballou et al. (2016), treatments or diets generally stimulated higher microbial differentiation at day 14, with the stronger and more stable taxonomy that characterizes the microbiota of broilers at day 28 being less likely to vary (Ballou et al., 2016). For this reason, for the microbiota investigation 12 broilers per diet (3 broilers per replicate diet) were randomly selected, after weighing at 14, and 28d and sacrificed for study. Initial sequence

analysis however did not reveal any significant dietary effect associated with collection time point and so to maximise the use of data, further analysis on dietary effects was carried out by combining data sets at the tissue specific level.

None of the supplementary treatments used in this study had a significant effect on the α - or β -diversity of the jejunum or caecal bacterial communities and as anticipated a lower microbial diversity was observed in general compared to that reported in other animals; this result was not unexpected and is thought to be due the more rapid transit of food through their digestive system (Wei et al., 2013; Rougère and Carré, 2010). On the other hand LEfSe analysis revealed that in the jejunum, the CTS diet was found to significantly modulate the proportion of the genus *Lactobacillus*, *Enterococcus*, *Clostridium*, and their respective families *Lactobacillaceae*, *Enterococcaceae* and *Clostridiaceae* when compared to the CTL diet but in contrast there were no modulation of any great significance when the CMB and the CTL had been compared and so the focus here will be on the modulatory effects of the CTS diet.

A higher abundance of *Lactobacillus* was found in the jejunum of broiler chickens fed the CTS supplemented diet. Several strains of *Lactobacillus* are widely used as probiotics with associated anti-inflammatory and anti-microbial activities in humans and animals (Corthésy et al., 2007). Although their mode of action is not completely understood, *Lactobacillus* based treatments have been shown to modulate the immune response (Brisbin et al., 2011), improve digestion and absorption of nutrients (Vieco-Saiz et al., 2019) and the fermentation of dietary fibres to produce SCFAs such as butyrate propionate acetate (Besten et al., 2013). Once released as a SCFAs these can be used as a source of energy for enterocytes or as an antimicrobial for pathogenic bacteria (Mao et al., 2019). Thus, the observed higher abundance of *Lactobacillus* in the jejunum in the current study is interpreted as the CTS diet potentially having a positive effect in terms of gut function and health. To further investigate this, it would be interesting to consider a follow up study aimed to measure SCFAs by high performance liquid chromatograph (HPLC) in broilers fed with CTS diet compared to CTL.

The abundance of bacteria belonging to the genus *Enterococcus* and *Clostridium* were found to be lower in jejunum for the CTS diet compared to CTL diet. *Enterococci* are physiologically part of the gastrointestinal microbiota of broilers but they are typically opportunistic pathogens and their role depends on the species (Dolka et al., 2017). For example, *E. cecorum* has been found to cause infections in broilers (Jung et al., 2017).

Likewise *E. faecalis* and *E. durans* have been frequently associated with poultry diseases, especially endocarditis in broilers (Velkers et al., 2011). In France, the increasing incidence of *Enterococci* in poultry farms over the last 15 years has been associated to the presence of this strain in the flock (Souillard et al., 2022). Many strains of *E. faecium* and *E. faecalis* have been discovered to be resistant to all currently available antibiotics (Miller et al., 2014). On the other hand, *E. faecium* is used commercially as a probiotic supplement in broiler diets where its use has been found to increase the diversity of the gut microbial population, improve intestinal absorbance and resistance to infections (Samli et al., 2007). Unfortunately, the 16srRNA sequencing methodology can only tell us about the abundance and diversity of bacteria and so taken as a whole the observed decrease in abundance of the genes *Enterococcus* is interpreted as beneficial.

The genus *Clostridium* is well known in the poultry sector, mainly because of the pathogenic species *C. perfringens*. But it's important to state that most of the bacteria in the *Clostridia* class are non-pathogenic commensals as of the gut, and many are even beneficial for animals (Rinttilä and Apajalahti, 2013). Indeed, many *Clostridium* species have been reported to participate in biological activities and thanks to their metabolites and cellular components are recognised to play a probiotic role (Guo et al., 2020). The study of Biddle et al. (2013) confirmed that some *Clostridium* bacteria are able to use the complex plant-derived carbohydrates to produce SCFAS in broilers. In the current study the abundance of the *Clostridium* decreased in the jejunum with the CTS diet. In the absence of any other supporting data, it is suggested that the shift in abundance of *Clostridium* is linked to the observed increase in abundance of *Lactobacillus*.

in the caecal study the results showed that the CTS modulated that the abundance of bacterial populations belonging to the genus *Blautia* and *Enterococcus* in the caeca, by respectively increasing and decreasing their abundance. On the other end, the CMB diet showed stronger modulation of *Bacillus* genus and their respective *Bacillaceae* family in the caeca.

Blautia belongs to the genus of anaerobic bacteria with probiotic effects that occur widely in the gut and faeces of mammals. According to Kiu et al. (2019), healthy broilers caecal microbiomes appear to have enhanced abundance of the genera *Blautia*. Members of the *Blautia* genus are known to be butyrate producers, and reductions in this genus have previously been associated with a *C. jejuni* infection model (Mountzouris et al., 2007). *Blautia* is a SCFAs producer in the gut, It helps her in the protection of the integrity of the

intestinal barrier functions and alleviate dextran sulfate sodium-induced inflammation (Yu et al., 2019). As butyrate is an important energy source for intestinal cells, it has been suggested that *Blautia spp.* may act as a key beneficial microbiota member, serving to enhance intestinal health of broilers by strengthening the epithelial barrier, thus preventing pathogenic microbes successfully colonising and initiating disease. This genus may also been implicated in roles associated with biotransformation and crosstalk with other intestinal microorganisms and in the inhibition of the insulin signalling and the fat accumulation in humans (Liu et al., 2021). Taken together this evidence suggests that the increase the abundance of *Blautia* in the caeca of broilers fed the CTS diet was beneficial to gut health.

The abundance of genus *Enterococcus* in the caeca for the CTS diet was lower when compared to the CTL diet. The influencer of the bioactive compounds in the CTL supplement on this genus of bacteria was therefore consistent in both of the jejunum and caeca and in both instances considered beneficial.

Bioactive compounds in CTS diet and their interaction with microbiota

The main differences in the microbial population are shown when CTS diet is administered to broilers. The citrus extract's bioactive compounds such as polyphenols, essential oils, pectin, carotenoids, or vitamins all or individually might be the reason of selective bacterial strains modulation. This is further complicated by gut environment modifications such as pH changes induced by some bacterial strains, could in itself increase or decrease the abundance of other bacteria. Polyphenols are recognised to possess prebiotic properties which support the growth of selective bacteria by acting as a source of nutrient supply (Marín et al., 2015). Among these bacteria, *Lactobacilli* and *Bifidobacteria* populations, are identified to be increased by polyphenols (Iqbal et al. 2020). In particular, flavonoids show antimicrobial potential against certain bacteria such as *S. aureus*, *Escherichia coli* (*E. coli*) and *Campylobacter* thanks to their ability to modulate the gut microbiota composition of broilers. The study of Tolnai et al. (2021) identified a decrease in the abundance of *Clostridium* in birds fed with flavonoids and highlight its association with a consequent alteration in bile biotransformation. Based on these considerations, the increase abundance of *Lactobacilli* and decrease abundance of *Clostridium*, found in our results, in the jejunum of broilers fed with CTS diet could be due to the polyphenol's content.

Essential oils which are generally extracted from the peel of citrus fruits contain high amounts of limonene and linalool (Manufacturer recommendation – NuScience) which can inhibit pathogenic bacteria in the small intestine of broilers; plant extracts have been already

demonstrated to have antimicrobial effect against pathogens in poultry and pigs (Mitsch et al., 2004; Bruggeman et al., 2002). Tiisonen et al. (2010) reported that blends of essential oils can increase the number of lactic acids, such as *Lactobacilli*, in broilers; this is in line with our findings as we observe an increase of *Lactobacilli* in the jejunum of broilers by administering CTS diet. Moreover, Erhan et al. (2012) found that the supplementation of the pennyroyal essential oil in the diet of broilers, increased lactic acids and decreased the count of *E.coli* in the jejunum. In line with our results, the increased number of *Lactobacilli* can be attributed to the antibacterial effect of citrus peel oils.

Furthermore, citrus extract contains high abundance of pectin. This dietary fiber is able to escape digestion and absorption so this characteristic makes them good candidates in the regulation of the gut microbiota (Mahmood and Guo, 2020). Differences in bacterial strains at the jejunum and caeca level can be influenced by pectin. Their mechanism of action *in vivo* trail of broilers is not clearly defined. However, *in vitro* studies demonstrated the ability of pectin to participate in the immune response of broilers (Ávila et al., 2021); no evidence is demonstrated on the modulation of microbiota by pectin.

The study of Tolnai et al. (2021) showed that carotenoids can reduce *Enterococcaceae* and *Clostridiaceae* families while positively modulate the abundances of the genus *Lactobacillus* in broilers. In accordance with our results carotenoids in CTS diet could modulate these bacterial strains. Further investigations on this compound are required to investigate its mechanism of action.

CTS diet is also a source of vitamin C which exerts anti-inflammatory and immunomodulatory properties. Broilers possess the ability to synthesize vitamin C in kidneys but higher level of vitamin C supplemented by a diet can alter the microbiota and contrast pathogens as *Salmonella* (Gan et al., 2020). It has been found that vitamin C is associated with the increase of beneficial bacteria *Lactobacillus* and *Bifidobacterium* in animals (Yang et al., 2020) but not a lot of information is available in broilers. This means that based on our result, the higher abundance of *Lactobacilli* in CTS diet could be also attributed to the presence of vitamin C in the extract.

Another reason that could cause alterations in the microbiota is the content of carbohydrates in CTS diet (Manufacturer recommendation – NuScience) (Yu et al., 2019); It has been reported that high concentrations of polysaccharides can modify the composition and diversity of the gut microbiota and increase the abundance of *Lactobacilli* in mice (Li et al.,

2019). In the same way, the presence of non-digestible carbohydrates such as fructooligosaccharides (FOS) can cause an increase in the abundance of *Blautia* genus in the caeca of broilers (Shang and Kim, 2019). *Blautia* and *Lactobacilli* are responsible to produce SCFAs that cause a change in the pH regulation of the gut (Yadav and Jha, 2019).

CTS diet is also a potential source of organic acids, such as citric acid, malic acid, oxalic acid, and malonic acid (Clements, 1964) (Manufacturer recommendation – NuScience), which can decrease the gut pH of broilers as well (Yu et al., 2019). Therefore, the modulation of the pH could consequently modify the growth of some other bacteria (Yadav and Jha, 2019).

Bioactive compounds of CMB and their interaction with microbiota

CMB diet appears to not have huge impact on the microbiota of broilers. This can also depend on the dosage and method of extraction of cucumber extract in the CMB diet (Manufacturer recommendation – NuScience). The bioactive compounds in CMB diet are mainly polyphenols, carotenoids and vitamins (Vouldoukis et al., 2004). The presence of these bioactive compounds, similarly to CTS diet, make CMB a potential candidate in the modulation of some bacterial strains (Muruganantham et al., 2016). The main genus found to be modulated by CMB is *Bacillus* in the caeca of broilers. The beneficial properties of *Bacillus* have been already explored (see Effects of CTS and CMB diets on the caecal microbiota above) but no evidence of correlations between its abundance and CMB compounds has been found. Further investigation is required; a possible approach could be an *in vitro* experiment to explore the impact of CMB compounds on *Bacillus* growth.

Comparison between jejunum and caeca microbiota

The caecal microbiota displayed a significantly higher richness, diversity and more complex a bacterial community compared to that found in the jejunum. These results are in line with previous reports (Shang et al., 2018; Cuccato et al., 2021; Xiao et al., 2021). The microbiota of the jejunum is mainly composed by *Lactobacillus*, *Enterococcus*, *Streptococcus* and *Lactococcus* genus. These bacteria all belong to the *Lactobacillales* order and in the current work they represented almost 45% of the total microbial population in the jejunum. These results are similar/ consistent with previous 16S rRNA gene-based studies (Stamilla et al., 2021). The microbial composition displayed in the jejunum is comparable to the one of ileum. Both regions of the small intestine have high percentage of the *Lactobacillaceae* family and *Lactobacillus*, *Enterococcus* genus (Gong et al., 2007) so I conclude that the two

regions in broilers are similar and comparable. In the caeca most of the OTUs were classified as *Lachnospiraceae* family, *Ruminococcus*, *Blautia* genus and *Bacteroidales* order. *Clostridium* and *Bacteroides* have been identified to be the predominant genera in the caeca by other studies (Xiao et al., 2017; Huang et al., 2021; Dauksiene et al., 2021). Based on our results, the caeca microbiota composition is in line with other studies and present high microbial variability which makes it reasonably the favourite candidate tissue in microbiota investigations.

Several studies have found that the intestinal microbiota of broilers is also modulated by age (Shang et al., 2018; Richards et al., 2019; Richards-Rios et al., 2020; Glendinning et al., 2019). In this study the richness of the microbiota increased in the caeca between day 14 and 28. In the jejunum, only a slight difference in microbial diversity was observed in both tissues between day 14 and day 28. This impact of age is higher on the caeca microbiota compared to the small intestine has been reported previously (Huang et al., 2018b); It's important to remember that caecal environment harbours a higher microbial richness and diversity during the entire life of broilers so there is a higher probability to find differences when multiple time points are compared. However, in our study, changes in the microbiota composition, mainly in the caeca, could be further complicated by the shift from starter to grower diet at day 14. Difference in the abundance of proteins and vitamins, in two dietary formulations, might also provoke alternations of the microbiota at different ages but as these changes should be consistent and are supported in the literature the differences seen from our CTL diet are of interest.

In the jejunum, mainly *Bifidobacteriaceae* families and some bacteria of the phylum *Actinobacteria* were found higher in abundance at day 14. This can be related to what stated by Amit-Romach et al. (2004) “the typical microflora of adult birds in the small intestine is established within 2 weeks”. Other studies demonstrated that microbial diversity is increased during chicken development, baking approximately at day 14 for the small intestine and 28 for the large intestine and then remaining stable (Huang et al., 2018b). In contrast, other studies affirmed that the microbial community structure along the GIT of boilers is quite stable during the period of skeletal growth (14 to 28d of age) while the higher differentiation is encountered after 40d old (Lu et al., 2003).

In the caeca, most of the age-related differences observed concerned *Lachnospiraceae*, *Ruminococcaceae*, families and other bacteria of the *Clostridiales* order. The abundance of *Bifidobacteriaceae* families and some bacteria of the *Lactobacillales* order were higher in

the caeca at day 14 but their abundance decreased at day 28. According to Torok et al. (2011) these are the most common families in the caeca of broilers. This was also confirmed by Richards et al. (2019) who found caecal microbiota dominated by *Ruminococcaceae* family and other *Firmicutes* of the *Clostridiales*. Stamilla et al. (2021) reported that *Lachnospirillum* genus, was found to be dominant from day 7 while *Bacteroides* genus displayed the highest percentage at day 25.

Jejunum morphometric measurements

In our study, CTS and CMB did not show any modulation of the villus length, crypt depth and epithelium height in the jejunum of broilers at 14 and 28d old. Histological data of broilers, when plant extracts are added to diets, is quite controversial. Similar to our study, Mounia et al. (2018) found that phytochemical products (PP), such as citrus oils, don't affect the morphology of villus length and crypt depth of jejunum in broilers of 42d old. On the other hand, Murakami et al. (2014) proved that essential oils, bioactive compounds in CTS diet, increase jejunum villus length on broilers at 14d old. In line with this, Erhan and Bölükbaşı (2017) suggested that orange peel oil (similar properties of citrus oils) has positive effects on jejunum morphology after 42d of experiment by increasing the villus length. The increasing villus length of broilers is an indicator of increased intestinal absorption surface which would promote the gut health of broilers. This study suggests that, if other measurements would have been taken in advanced age of broilers (e.g 42d), maybe an increase in villus length could have been observed in broilers fed with CTS diet.

The only significant modulation of morphometric measurements, with an increase in villus length, crypt depth and epithelium height were found by age (14 vs 28d) irrespective to diet. Intestinal morphology has been already demonstrated to be influenced by the age of broilers (Ariyadi et al., 2019). Some studies also demonstrated that the BW of broilers has a direct effect on the gut morphology; villus atrophy and crypt hypertrophy was discovered in broilers with retarded growth (Lenhardt and Možeš, 2003). From the histology perspective, all diets were found comparable so no differences in terms of gut morphometric measurements were attributed to CTS or CMB diets.

Growth performance

In our results, CTS and CMB diets depressed the BW of broilers from the age of 14 to 28d old. Some studies highlight the positive effects of plant extracts in increasing the BW of broilers which is in contrast with our findings (Eltazi, 2014; Zhu et al., 2019). The FI was studied and revealed differences among dietary treatments as well; broilers fed with CTS diet had a significantly lower FI compared to CTL at day 7 and 21 while broilers fed with CMB showed a significant lower FI compared to CTL at all time points. Similarly, the study of Islam et al., (2012) found a decrease in FI in broilers fed with citrus extract; broilers fed with this diet ate less because they don't like its taste and consequently showed a lower BW. However, data from some other literature indicate that compounds in plant extracts (e.g citric acid) could stimulate the appetite of broilers (Krauze et al., 2021); this reflected the behaviour of broilers in CTS diet in our trial 2 (see 3.2.1 Trail 2 Experimental design – chapter 3). The dietary modulation of FI was connected as first to environmental changes (e.g temperature/humidity) in dietary pens but no circumstances have been identified as possible causes of these changes. Furthermore, based on BW and FI, a higher FCR was observed when broilers were fed with CTS diet while no differences were detected with CMB diet. It's important to remember that FCR value should be as low as possible to be economically valuable for poultry industries (Siegel, 2014).

In the literature, growth performance data on broilers (BW, FI and FCR of broilers) fed with plant extracts are controversial. Akbarian et al. (2013) showed that lemon and orange peel extracts supplemented to the finisher diet don't have any effects on the FCR and BW of broiler chickens. The study of Khattak et al. (2014) found that natural blend of essential oils increase the BW of broilers. Zhu et al. (2019) observed an increase in growth performance when broilers are fed with plant extracts. These contradictory findings indicates that further investigation is required to better understand the effects and mechanism of action of plant extracts, such as citrus and cucumber, on the performance and related microbiota of broiler chickens.

Conclusions

The gut health of broilers was explored by studying the influence of CTS and CMB on the gut microbiota, histological morphometric measurements, and growth performance.

Significant progress has been made in understanding the taxonomic composition of the GIT microbiota and its contributions to gut health but It would be interesting, to apply multi-Omics approaches or nanopore long-read sequencer MinION™ in order to increase our understanding on the role of diets on the microbiota in nutrition, health, disease, and productivity (Shang et al., 2018).

Our results showed that the CTS and CMB diets did not significantly affect the overall bacterial taxonomy but some the proportions of bacterial strains in the jejunum and caeca of broilers were modulated. A significant difference in the microbial composition was found between the two different tissues (caeca vs jejunum). Bird age had a slight effect mainly at caecal level (day 14 vs day 28). While differences due to gut sites and age were investigated our main aim was to study possible bacterial strains modulated by CTS and CMB and consequently their impact on gut health. Most bacteria modulated by CTS diet do indeed have positive effects in the stimulation of the immune system, absorption of nutrients and production of SCFAs in broilers. Most of these bacteria are involved in broiler's metabolism. These data will then be compared to our metabolomics findings (see chapter 5 and 6). The intestinal microbiota alteration in response to CTS diet might be due to polyphenols, essential oils, carotenoids, vitamins, polysaccharide and/or organic acid in citrus extracts but their mechanisms of action on the microbiota need further studies. In the complex, CTS diet might be a promising resource to promote the health of broilers while CMB diet appears less.

Both experimental diets did not show effects in the modulation of gut morphometric measurements. Similarly, growth performance differences were mainly related to the CTS diet but in terms of the extent of the decreased BW, FI and increased FCR, during broiler's growth that it suggests it is unlikely to prove of value as a growth promoter for poultry industries. However, if CTS diet could improve broilers health, even if the growth performance result here was true (as it is in contrast to Nutrition Sciences field studies) it could still represent a valid antibiotics growth promoter alternative by improving health (further discussion in chapter 7). In order to widely investigate the influence of diets on broiler's health, it would be useful to study their role during inflammation. For this reason, in chapter 3 an *in vivo* trial was performed using the same experimental facilities and diet of trial 1 but by challenging broilers at 15d old with *E. coli* LPS, a bacterial endotoxin known to stimulate the innate immune system. The study of APR and its dietary influence will help to clarify the role of CTS and CMB diets in broilers.

Chapter 3 Novel biomarkers to assess the effect of novel plant extracts on the immune response pre and post LPS challenge

3.1 Introduction

Escherichia coli is a Gram-negative pathogenic facultative anaerobe bacterium of the *Enterobacteriaceae* family that can have a significant impact on poultry production (Kemmett et al., 2014). Lipopolysaccharide (LPS) is an essential component of the outer membrane of Gram-negative bacteria such as *E.coli* (Bertani and Ruiz, 2018). LPS can induce endotoxemia and consequently activate the immune response in broilers (Ghareeb et al., 2016) (see 1.2.2 *Escherichia coli* endotoxin (LPS challenge) - chapter 1). Based on its properties, the injection of bacterial LPS in birds is a widely used model to stimulate the immune system without the need to use infectious agents which can be more difficult to control (French et al., 2020). However, their response depends on the method employed (e.g single/multiple doses and the injection site).

The broilers immune response activated by LPS leads to the production of inflammatory molecules such as cytokines and chemokines (Haudek et al., 2003), that can initiate a complex network of secondary reactions including the production of acute phase proteins (APPs) (Ceciliani et al., 2002). APPs are generally produced in the liver and then secreted into the blood (O'Reilly and Eckersall, 2014). Thus, the presence of APPs in the plasma serve as useful physiological biomarkers for health and welfare in chickens. APPs known to be modulated in broilers during the acute phase response (APR) include Serum amyloid A (SAA), α 1-acid-glycoprotein (AGP), Ovotransferrin (OVT), Ceruloplasmin, Fibrinogen, Fibronectin, Hemopexin (Hpx) , PIT54 (the chicken equivalent of haptoglobin) and Mannan binding lectin (O'Reilly and Eckersall, 2014).

Among these, the main established APPs in broilers are SAA, AGP and OVT. SAA is a small APP (~12kDa) which circulates in blood and increase its expression >100-fold following infection (Matulova et al., 2013); AGP is a useful established biomarker in broilers which elevated 5-fold or more in serum due to the immune system stimulation (Takimoto et al., 2008); OVT is another positive APP in chickens (Xie et al., 2002) with numerous studies confirming that its serum level increases when APR is stimulated following infection. However, SAA and AGP concentrations can be measured using the commercially available ELISA assays while OVT which requires other methodology such as the Radial immunodiffusion assay (O'Reilly, 2016).

Recently, a proteomics approach (Horvatić et al., 2019) found that plasma levels of Hpx and LCN8 extracellular fatty acid binding protein (ex-FABP) precursor were modulated in broilers under LPS challenge and may be potential biomarkers of toxicity. Hpx is a protein of ~60kDa which has previously been reported by the study of Grieninger et al. (1986) to increase 5-fold during the APR in broilers elicited by injection of chickens with turpentine. More recent work has suggested that Hpx can increase by 25-fold under challenge conditions (Dr. Chris Chadwick Life Diagnostics – personal communication March 2022). Ex-FABP is a 21 kDa lipocalin which increases from 0.5 to 10µg/ml during challenge (Dr. Chris Chadwick Life Diagnostics – personal communication March 2022). This protein has been reported to increase its level in response to inflammation (e.g LPS) and tissue degeneration in chickens (Cermelli et al., 2000). Ex-FABP is a protein physiologically expressed during endochondral bone formation, and other cell differentiation pathways but it is highly enhanced during APR in broilers (Cermelli et al., 2000).

Another APP of growing interest in broiler chickens is MRP-126 (~15kDa). MRP-126 belongs to the calgranulin protein family and recent proteomics investigations found its faecal level to increase ~40-fold after bacterial infection (Dr. Chris Chadwick Life Diagnostics – personal communication March 2022). This protein has also been identified as a novel APP which interacts with the innate immune system and gut of chickens after oral infection with *Salmonella*. The study of Matulova et al. (2013) reported the level increased ~100-fold following bacterial infection suggesting its role in modulating the growth of certain microbes that consequently influence the immune response of broilers.

As discussed in detail in chapter 1 when broilers immune response is stimulated, the active compounds in the two dietary supplements under investigation in this thesis (citrus and cucumber) are thought to either bind to the bacterial LPS or alter the pattern recognition receptors (Toll-like receptors) of macrophages, neutrophils, dendritic cells, thereby attenuating the damaging effects of LPS (Bernardini et al., 2018; Chen et al., 2006). In broilers, citrus compounds has shown immunomodulatory effects *in vitro* (Ávila et al., 2021) and *in vivo* (Ebrahimi et al., 2015; Chen et al., 2006) while less information are available on cucumber compounds. To date there is no information on whether specific APPs are modulated in broilers fed with one of these extracts under challenge conditions. Based on these considerations, this chapter describes a LPS challenge experiment where the plasma

concentrations of established and novel APPs were studied to evaluate the APR of broilers fed on CTS, CMB or CTL diets.

3.1.1 Aims and Objective of the study

The aim of this study was to compare the responses of two well established APPs (AGP and SAA) and three more novel APPs (Hpx, Ex-FABP and MRP-126) in broiler plasma following an LPS challenge and to test the hypothesis that the feed of broiler chickens, supplemented with citrus or cucumber extracts, has an immunomodulatory effect on the APR over a time course of 48h. To investigate this aim, APPs were studied in plasma of 15d old broilers sampled at T0h pre challenge and T12,24,48h following LPS treatment.

Previous investigations have revealed that SAA is more sensitive to *E. coli* LPS challenge than AGP (Horvatić et al., 2019). Further academic-industrial collaboration with Life Diagnostics USA, has led to antibody production to chicken Hpx, ex-FABP, MRP-126 and the development of ELISA assays that can detect these proteins in broiler plasma (Life Diagnostics Inc, West Chester, USA). Other immunoassay formats such as the Spatial Proximity Analyte Reagent Capture Luminescence (SPARCL™) are also under development to increase the precision and speed of measuring APPs. In this study, AGP, SAA, ex-FABP and Hpx levels were measured using ELISA assays while MRP-126 was measured using a novel innovative SPARCL™ assay with the key objective of characterising the time course response of the 3 novel APPs with that of SAA and AGP during LPS challenge conditions and to determine if the abundance of each of these APPs was modulated by dietary regimen.

The knowledge generated about different APPs and their plasma concentration under challenge conditions is extremely useful in understanding these different components of the APR and their use as biomarkers of not just disease in general but possible specific types of disease and specific responses to different dietary supplements.

3.2 Materials and methods

3.2.1 Trial 2 Experimental design

A total of 144 one-day-old male vaccinated broiler chickens (Ross 308) were collected from the PD Hook Hatcheries Ltd, Bampton, UK and raised for 15 experimental days at Cochno farm & Research Centre, Glasgow (same facilities and rooms of trial 1- see chapter 2 - Experimental design and diets). Each bird was fitted with unique wing tags, weighed and randomly allotted to one of the three diets: Diet 1) control (CTL): commercial starter and grower diet without any supplements, Diet 2) cucumber (CMB): diet 1 supplemented with cucumber extracts (75 g/ton diet), Diet 3) citrus (CTS): diet 1 supplemented with citrus extracts (300 g/ton diet). The basal starter diet used was corn-soybean meal-based diets, formulated and prepared at NuScience, Ghent, Belgium (see Table 2.1 – chapter 2). Chicks were divided in groups of 12 and raised in 12 pens (4 replicate pens/each diet) across the two rooms in the same environmental conditions (temperature, humidity, and lighting) and adopting the same biosecurity measures as described for trial 1 (see 2.3.1 Trial 1 Experimental design - chapter 2). On day 0, 8 and 15 each bird (N=144) was weighted, using a weight balance (0.001 g). A general linear model (GLM) and Turkey test was run on RStudio (version 4.0.0) to evaluate any effects of diet (CTL, CTS and CMB) on BW at day 8 and day 15. During the trial, 1 bird died following LPS challenge but the post mortem examination assessed that death was due to natural causes.

3.2.2 LPS challenge and plasma collection

At the age of 15d, plasma was collected from 12 birds per treatment (3 birds per pen and replicate). All birds were then injected subcutaneously with *E.coli* lipopolysaccharide (LPS from *E. coli* O111:B4 purified by phenol extraction, L2630-25MG; Sigma-Aldrich, Dorset, UK) (2 mg/kg body weight) in a volume of 0.5 ml. Plasma was then collected from the same 12 birds per treatment at 12-, 24- and 48h post LPS injection. At each time point approximately 1 ml of blood was collected from the brachial vein using a 2ml syringe and then placed in heparinized tubes to prevent blood clot. The Blood samples were then centrifuged (2000 x g) for 15 min at 4 °C and the plasma aliquots immediately frozen at -20°C.

After 48h the trial was ended and all birds were humanely euthanised by Schedule 1 procedure by administering an overdose of a Barbituate anaesthetic agent (1ml/kg of Pentobarbital sodium R Euthatal Dopharma Research B.V.), injected into the brachial vein.

Note: The remaining birds used in this trail were euthanised for tissue collection (12 birds per treatment) at pre (0h), T12h and T24h post LPS injection. Tissues included liver and breast muscle. Tissues from the 12 birds per treatment used for plasma collection were also harvested at T48h for further investigation (see chapter 4 and 6).

This animal experiment was approved by the Home Office, Animals in Science Regulation Unit (ASRU), Glasgow, under the license number P4A4CA831.

3.2.3 APP summary workflow

The established APPs (SAA, AGP) and novel APPs (Hpx, ex-FABP) levels were measured in each plasma sample (N=141) using commercially available ELISA kits while the novel APP, MRP-126, was measured using the new SPARCL™ assay. ELISA and SPARCL™ assays for APPs detection were obtained from Life Diagnostics Inc. (West Chester, USA) (Figure 3.1). The assays were performed according to the manufacturer's protocols with specific dilution per each APP as explained in the sections below. Non-parametric tests were used to study the effect of LPS pre and post challenge and diets on APPs abundances. The data acquired on novel APPs (Ex-FABP, Hpx and MRP-126) were then compared to the established APPs (AGP and SAA).

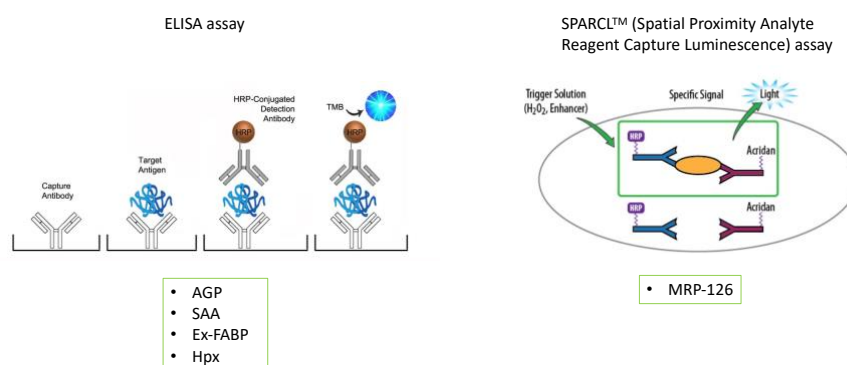

Figure 3.1 Immunoassays (ELISA and SPARCL™) used to analyse the APPs.

The ELISA assay used affinity purified chickens APP antibodies for solid phase immobilization and horseradish peroxidase (HRP) conjugated chicken APP antibodies for detection. The SPARCL™ assay uses two APP antibodies, one conjugated to HRP for detection and the other conjugated to a chemiluminescent substrate (acridan). The ELISA assay was used to evaluate the abundance of AGP, SAA, Ex-FABP and Hpx while the SPARCL™ was used to study the abundance of MRP-126 in this study (modified from ThermoFisher Scientific (2016) and <http://www.lumigen.com/products/elisa/lumigen-sparcl>)

3.2.3.1 ELISA for AGP

The commercially available assay used for the detection of AGP, utilized affinity purified chickens AGP antibodies for solid phase immobilization and horseradish peroxidase (HRP) conjugated chicken AGP antibodies for detection (Life Dianostics, Inc. Catalog Number: AGP-5). The method has been previously used and validated by Horvatić et al., (2019). Four Elisa plates (96 microtiter wells/plate) were used to examine the AGP concentration of 141 broilers plasma samples (12 samples x 3 diets x 4 time points). Experimental samples and 2 quality control samples (high and low AGP concentrations) were diluted 10,000-fold and dispensed into duplicate wells of each 96-well microtiter plate coated with anti-AGP together with a detector antibody conjugated to HRP (100µl). Standards were diluted 7 times from 150ng/ml to 2.34ng/ml following the manufacturer instructions. Each plate, containing samples and standards, was then incubated on the orbital microplate shaker at 150 rpm at room temperature for 45 min. Then, wells were emptied and washed five times using the wash buffer provided with the kit, ensuring all residual droplets were removed by striking plates onto absorbent paper. 100µl of the secondary antibody-HRP conjugate was added into each well and the plates incubated at room temperature for 45 min. The washing step was repeated using the wash buffer to ensure to have removed unbound HRP-conjugate. Then, 100µl of TMB reagent (HRP substrate) was dispensed into each well. This led caused a colour change (from yellow to blue) in all wells. Plates were then placed on a shaker at room temperature and the reaction stopped using 100µl of stop solution. The absorbance of each sample was measured at 450nm using a FLUOstar Optima plate reader within 15 min of stopping the reaction. The standard curve was generated using a four-parameter logistic curve (4PL) from the Optima software. If A450 sample's concentration fell inside the standard curve, an appropriate dilution was applied (Figure 3.2). The precision of each ELISA kit was determined by comparing plasma samples in duplicate within the same plate and by comparing the two quality control samples (high and low APP concentration) among the different plates.

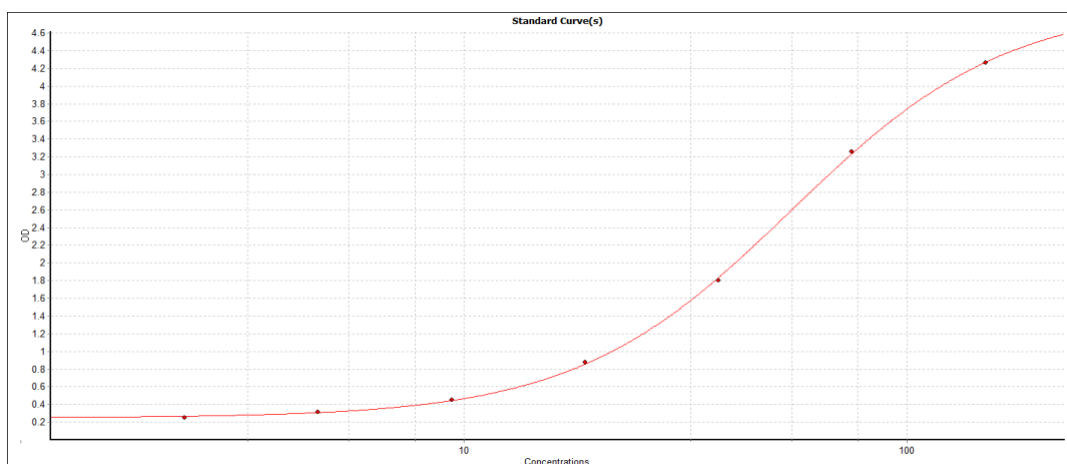

Figure 3.2 Example of standard curve obtained from the Optima software (AGP assay).

The curve intersects all dots which identify the different concentrations of AGP standards (150, 75, 37.5, 18.75, 9.38, 4.69, 2.34 ng/ml).

3.2.3.2 ELISA for SAA

The commercial assay for the detection of SAA uses two different peptide-specific chicken SAA antibodies, the first one is used for solid phase immobilization and the second is conjugated to horseradish peroxidase (HRP) for detection (Life Dianostics, Inc. Catalog Number: SAA-5). This method has been previously used and validated by Horvatić et al., (2018). Five Elisa plates (96 microtiter wells/plate) were used to examine the SAA concentration of the 141 broilers plasma samples (12 samples x 3 diets x 4 time points). Each individual sample was run in duplicate, including 2 known quality control samples of high and low SAA concentration. Adjustments were made to the dilution factor (10-fold was recommended by the protocol) because the SAA concentration was too high to be detected in the standard range. The following dilutions were applied:

- 20-fold dilution at T0h (pre challenge) and T48h (post challenge)
- 80-fold dilution at T24h (post challenge)
- 1248-fold dilution at T12h (post challenge)

Adjustments in the plasma volume used for the analysis were also needed because of the small amount recovered from the birds. 12.5 μ l were used instead of the 100 μ l recommended by the protocol. Once diluted samples and standards were dispensed in duplicates into the 96-well microtiter plate coated with anti-SAA for 1h. 100 μ l of secondary antibody HRP-conjugate was dispensed into wells before the plate incubation at room temperature for 45 min and a series of washing steps using the wash buffer were performed. TMB reagent (100 μ l) was dispensed into wells and plates were moved to a shaker for 20

min where they developed a blue colour. The reaction was then stopped by adding 100 μ l of stop solution and reading the plate at 450nm using a FLUOstar Optima plate reader. SAA concentrations which fell inside the standard curve (Figure 3.3) were used for the analysis. For some timepoints the ELISA procedure was repeated by using different sample's dilution as explained above. The precision of each ELISA kit was determined as described in section 3.2.3.1.

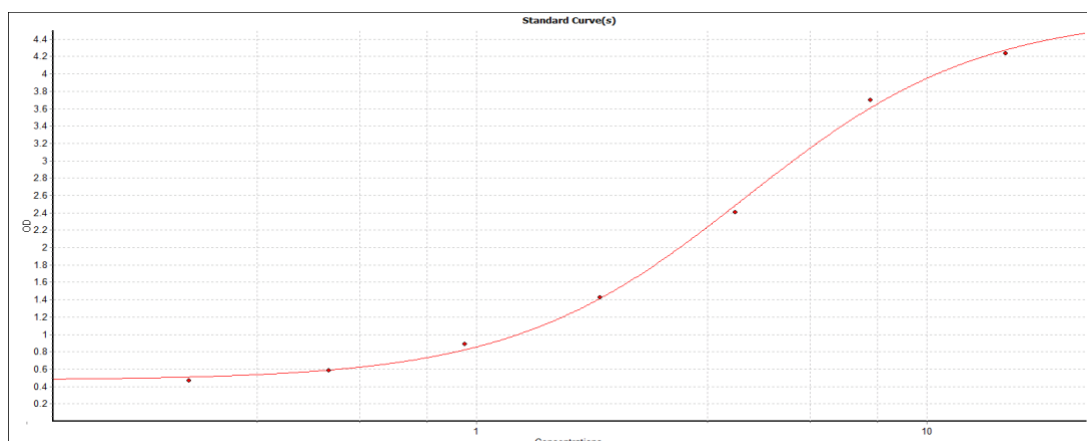

Figure 3.3 Example of standard curve obtained from the Optima software (SAA assay).

The curve intersects all dots which identify the different concentrations of SAA standards (15, 7.5, 3.75, 1.88, 0.94, 0.47, 0.23 ng/ml)

3.2.3.3 ELISA for Ex-FABP

The available ELISA assay for Ex-FABP uses two chicken EX-FABP antibodies, one for solid-phase immobilization and the second is conjugated to HRP for detection (Life Diagnostics, Inc. Catalog Number: ExFABP-5). Samples were analysed directly in Life Diagnostics, Inc following the standard protocol provided by the company. Elisa plates (96 microtiter wells/plate) were used to examine the Ex-FABP concentration of 141 broilers plasma samples and 2 known control samples (high and low concentration of Ex-FABP). Each individual sample was diluted 2,000-fold and run-in duplicate with Ex-FABP standards on the same plate. The protocol performed followed the instructions provided by the manufacturer which can be summarised in the following steps: 100 μ l of HRP-conjugate was added into wells along with 100 μ l of standards and samples, the plate was incubated on an orbital micro-plate shaker at 150 rpm (room temperature) for 1 hour, a series of washing steps applied, TMB solution (100 μ l) dispensed in each well before the incubation on a micro-plate shaker at 150rpm for 20 min, stop solution (100 μ l) was added into each well and the absorbance of each sample, including the standards, measured at 450nm using a FLUOstar Optima plate reader. Ex-FABPs for each sample was calculated based on the

standard curve generated from the Optima software. The precision of each ELISA kit was determined as described in section 3.2.3.1.

3.2.3.4 ELISA for Hpx

The commercially available ELISA kit for the detection of Hpx has been developed by Life Diagnostics, Inc (Catalog Number: Hpx-5). This assay uses two chicken Hpx antibodies, one for solid-phase immobilization and the second is conjugated to HRP for detection. Samples were analysed in Life Diagnostics, Inc following the manufacturer protocol which similar to the AGP, SAA and Ex-FABP ones. Experimental (N=141) and 2 quality control samples were diluted 40,000-fold and 100µl added to the 96 microtiter wells ELISA plate as well as the standards (100 µl). Wells were subsequently washed using a wash solution and HRP-conjugate added to each well and incubated for 45 min on a plate shaker (150 rpm, room temperature). Once the wells were washed again to remove unbound HRP-conjugate, 100 µl of TMB were added and the plate incubated for 20 min on the plate shaker (150 rpm, room temperature). The reaction was stopped by adding of stop solution and the absorbance of each sample measured at 450 nm using a FLUOstar Optima plate reader. The concentration of Hpx was derived from the standard curve. The precision of each ELISA kit was determined as described in section 3.2.3.1.

3.2.3.5 SPARCL™ for MRP-126

SPARCL™ assay for the detection of MRP-126 is under development and optimization in chickens. The assay uses two chicken MRP-126 antibodies, one conjugated to HRP for detection and the other conjugated to a chemiluminescent substrate (acridan). When the two conjugated antibodies bind to MRP-126, hydrogen peroxide is added and HRP can catalyse oxidation of proximal acridan molecules which led to chemiluminescence and allow rapid measurement of MRP-126 concentrations using a luminometer. Samples were analysed directly in Life Diagnostics, Inc. using SPARCL™ plates (96 microtiter wells/plate) to examine 141 broilers plasma samples. Each individual sample was diluted 200-fold and run-in duplicate with standards on the same plate. The protocol can be summarised in the following steps: 25.0µl of conjugate mix into were aliquoted into each well along with 50µl of standards and diluted samples, the plate was incubated on an orbital micro-plate shaker at 150 rpm (room temperature) for 30 minutes. Then the trigger solution was added to each

well and the luminescence was read using a luminometer. MRP-126 for each sample was calculated based on the standard curve generated from the Optima software.

3.2.4 Statistical analysis for APPs

GraphPad Prism v.9.1 was used for statistical analysis to explore the effects of diets (CTL, CTS and CMB) and LPS challenge at all time points pre and post challenge (T0,12,24,48h) on AGP, SAA, Ex-FABP, Hpx abundance. All results were analysed using a General Linear Model (GLM) with Tukey post-test analysis. When the interaction diet x time point was found not significant ($p > 0.05$), data from the same diet was combined to increase the sample size.

3.3 Result

3.3.1 Body weight and dietary treatment pre LPS challenge

No significant interaction was discovered between BW and each dietary treatments/bird age. Based on different diet's administration, no difference was found in terms of BW at day 0, 8 and 15 of age. The only significant difference was based on broiler's growth at their different ages ($p < 0.001$) (Table 3.1).

	Diet	Day 0				Day 8				Day 15			
		N	Mean	±	SE	N	Mean	±	SE	N	Mean	±	SE
BW (Kg)	CTL	47	0.040	±	0.000 a	47	0.192	±	0.003 ^b	47	0.490	±	0.006 ^c
	CTS	48	0.041	±	0.000 a	48	0.194	±	0.002 ^b	48	0.493	±	0.006 ^c
	CMB	48	0.041	±	0.000 a	48	0.202	±	0.013 ^b	48	0.486	±	0.006 ^c

Table 3.1 BW (Kg) of broilers on CTL, CTS and CMB supplemented diets at 0,8,15d of age

The table indicates the number of broilers (N), the mean and standard error of the mean (SE). Means that do not share a letter are significantly different. No differences in terms of BW were observed at day 0,8,15 of age.

3.3.2 Acute Phase Proteins

3.3.2.1 Plasma concentration of AGP

The mean and SE of AGP concentrations (ng/l) in broilers fed with the three diets (CTL, CTS and CMB) at all time points, pre and post LPS challenge (T0,12,24,48h), are represented in Figure 3.3. AGP levels significantly increased in response to LPS and peaked at T24h; then decreased again at T48h irrespective of treatment.

In general, there was no evidence of any dietary modulation of AGP. A lower AGP mean was discovered in CMB diet at T24h post compared to CTS. This difference however was mainly attributed to outlier samples in the CTS T24h group which displayed a higher AGP concentrations compared to the other samples (see CMB T24h in Figure 3.4).

Based on these results the main effect of LPS challenge was studied without considering the “diet” variable. No difference was found in T12 and T48h post challenge while a significant difference ($p < 0.001$) was discovered in all the other time points (Figure 3.5). The concentration of AGP resulted increased ~8-fold from T0h pre challenge to T24h post challenge (peak).

		<i>T0</i>				<i>T12</i>				<i>T24</i>				<i>T48</i>			
	Diet	N	Mean	±	SE	N	Mean	±	SE	N	Mean	±	SE	N	Mean	±	SE
<i>(mg/ml)</i>	CTL	12	0.1304	±	0.0124 ^a	11	0.4928	±	0.0273 ^b	11	0.8741	±	0.0613 ^{cd}	11	0.4588	±	0.0372 ^b
	CTS	12	0.1678	±	0.0183 ^a	12	0.5086	±	0.0191 ^b	12	1.0508	±	0.0598 ^c	12	0.5756	±	0.0350 ^b
	CMB	12	0.1503	±	0.0144 ^a	12	0.4543	±	0.0210 ^b	12	0.8311	±	0.0683 ^d	12	0.4621	±	0.0496 ^b

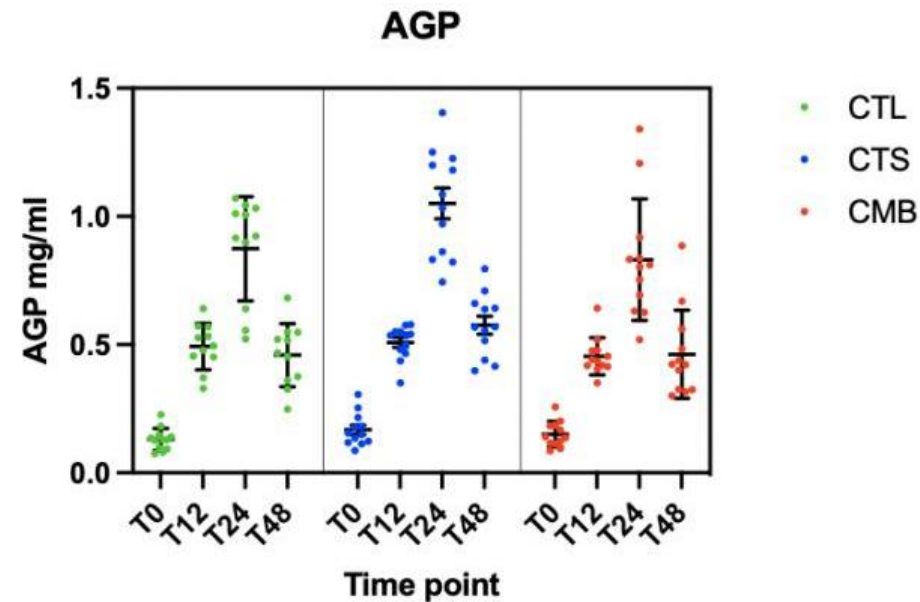

Figure 3.4 Table and scatter plot of AGP concentration based on different diets (CTL, CTS, CMB) pre (T0) and post (T12, T24, T48) challenge

The table indicates the number of samples (N), the mean and standard error of the mean (SE). Means that do not share a letter are significantly different. The data is also represented in the accompanying scatter plot. No differences in AGP concentrations were found based on CTS and CMB vs CTL diet while a significant difference ($p < 0.001$) was observed during LPS challenge (T12, T24, T48) compared to T0. The highest AGP concentration was observed at T24h post challenge in all diet.

	<i>Time point</i>	<i>N</i>	<i>Mean</i>	\pm	<i>SE</i>
<i>AGP</i> (<i>mg/ml</i>)	0	36	0.1495	\pm	0.00892 ^a
	12	35	0.4850	\pm	0.01320 ^b
	24	35	0.9199	\pm	0.03910 ^c
	48	35	0.5000	\pm	0.02500 ^b

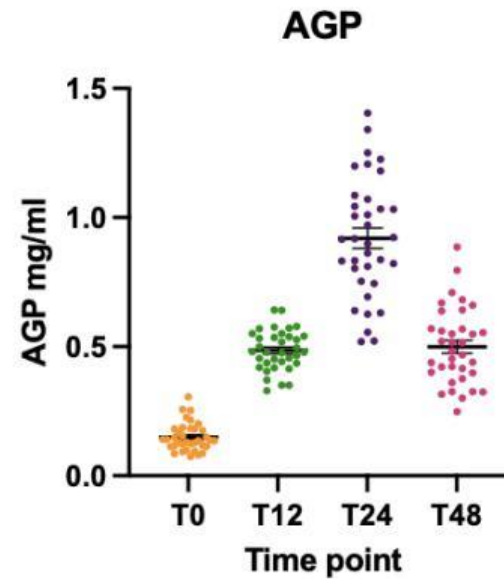

Figure 3.5 Table and scatter plot of AGP concentration based on LPS challenge at T0

The table indicates the number of samples (*N*), the mean and standard error of the mean (*SE*). Means that do not share a letter are significantly different. The data is also represented by the scatter plot. A significant increase in AGP concentrations ($p < 0.001$) was found at T12, T24 and T48 compared to T0h. No difference was observed between T12 and T48h post challenge.

3.3.2.2 Plasma concentration of SAA

The mean and SE of SAA concentrations (mg/ml) was calculated in all broilers fed with the three diets (CTL, CTS and CMB) at all time points, pre and post LPS challenge (T0,12,24,48h) (Figure 3.6). To better study differences in SAA, quantities have been transformed by the function log10 for the Figures below. The two variables (diets and timepoints) were found to be independent. SAA levels significantly increased in response to LPS at T12h post challenge ($p < 0.001$) compared to T0, T24 and T48h. SAA concentration at T12h was found to be extremely high in all samples, being >2 mg/ml in many samples compared to all the other time points. No significant dietary effects were found at any of the sampling time points.

Based on these considerations, the LPS challenge effect was studied excluding the variable “diet”. No difference was found in T0, T24 and T48h post challenge while a significant statistical difference ($p < 0.001$) was discovered at T12h compared to all the other time points (Figure 3.7). The concentration of SAA increased around ~2000-fold from T0h pre challenge to T12h post challenge (peak). This reduced considerably by T24h and was completely back to normal (T0h) concentrations by of T48h.

		<i>T0</i>				<i>T12</i>				<i>T24</i>				<i>T48</i>			
	Diet	N	Mean	±	SE	N	Mean	±	SE	N	Mean	±	SE	N	Mean	±	SE
<i>(mg/ml)</i>	CTL	12	0.0009	±	0.0002 ^a	11	2.2830	±	0.1310 ^b	11	0.0246	±	0.0046 ^a	11	0.0016	±	0.0003 ^a
	CTS	12	0.0010	±	0.0002 ^a	12	2.2680	±	0.1880 ^b	12	0.0309	±	0.0056 ^a	12	0.0017	±	0.0003 ^a
	CMB	12	0.0011	±	0.0001 ^a	12	1.9490	±	0.1290 ^b	12	0.0277	±	0.0048 ^a	12	0.0019	±	0.0004 ^a

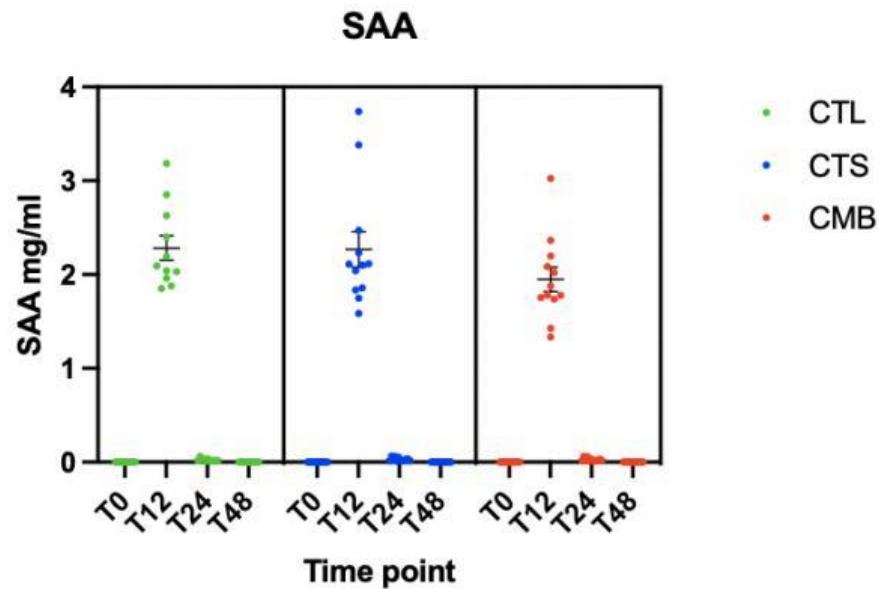

Figure 3.6 Table and scatter plot of SAA concentration based on different diets (CTL CTS, CMB) pre (T0) and post (T12, T24, T48) challenge

The table indicates the number of samples (N), the mean and standard error of the mean (SE). Means that do not share a letter are significantly different. The data is also represented in the accompanying scatter plot. SAA levels increase at T12h post challenge ($p < 0.001$) while no significant differences were observed based on broilers diets at all other time points.

	<i>Time point</i>	<i>N</i>	<i>Mean</i>	\pm	<i>SE</i>
<i>SAA (mg/ml)</i>	0	36	0.0010	\pm	0.0001 ^a
	12	35	2.1634	\pm	0.0898 ^b
	24	35	0.0278	\pm	0.0029 ^a
	48	35	0.0017	\pm	0.0002 ^a

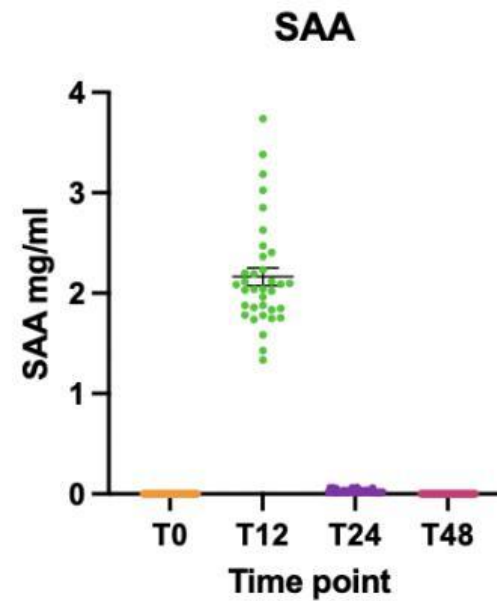

Figure 3.7 Table and scatter plot of SAA concentration based on LPS challenge at T0

The table indicates the number of samples (*N*), the mean and standard error of the mean (*SE*). Means that do not share a letter are significantly different. The data is also represented by the scatter plot. A significant increase ($p < 0.001$) of SAA was found at T12h post challenge compared to T0, T24 and T48.

3.3.2.3 Plasma concentration of Ex-FABP

The mean and SE of Ex-FABP concentrations (ug/ml) in broilers fed with CTL, CTS and CMB at all time points, pre and post LPS challenge (T0,12,24,48h), are displayed in Figure 3.8. The two variables (diet and timepoints) were found to be dependent ($p < 0.05$); this is reflected in the significant difference ($p < 0.05$) between CTS and CMB diet at T12 and T24h. Ex-FABP concentration was found to significantly increase (~20-fold) in response to LPS in all diets by peaking at T12h; then the level decreased at T48h but remained still higher compared to T0h pre challenge.

A significant difference was observed comparing the CTS vs CMB diet at T12h and T24h, in both cases the CTS diet showed a higher abundance of Ex-FABP ($p < 0.05$). There was no difference however in Ex-FABP concentration when the CTL diet was compared to each experimental diet (CTS and CMB).

	Diet	T0				T12				T24				T48			
		N	Mean	±	SE	N	Mean	±	SE	N	Mean	±	SE	N	Mean	±	SE
Ex-FABP (ug/ml)	CTL	12	0.423	±	0.078 ^f	11	17.169	±	0.566 ^{ab}	11	13.325	±	0.397 ^{cd}	11	3.594	±	0.464 ^e
	CTS	12	0.495	±	0.049 ^f	12	19.725	±	0.805 ^a	12	16.213	±	0.784 ^{bc}	12	4.809	±	0.306 ^e
	CMB	12	0.413	±	0.100 ^f	12	16.685	±	1.120 ^b	12	11.993	±	1.020 ^d	12	3.203	±	0.569 ^e

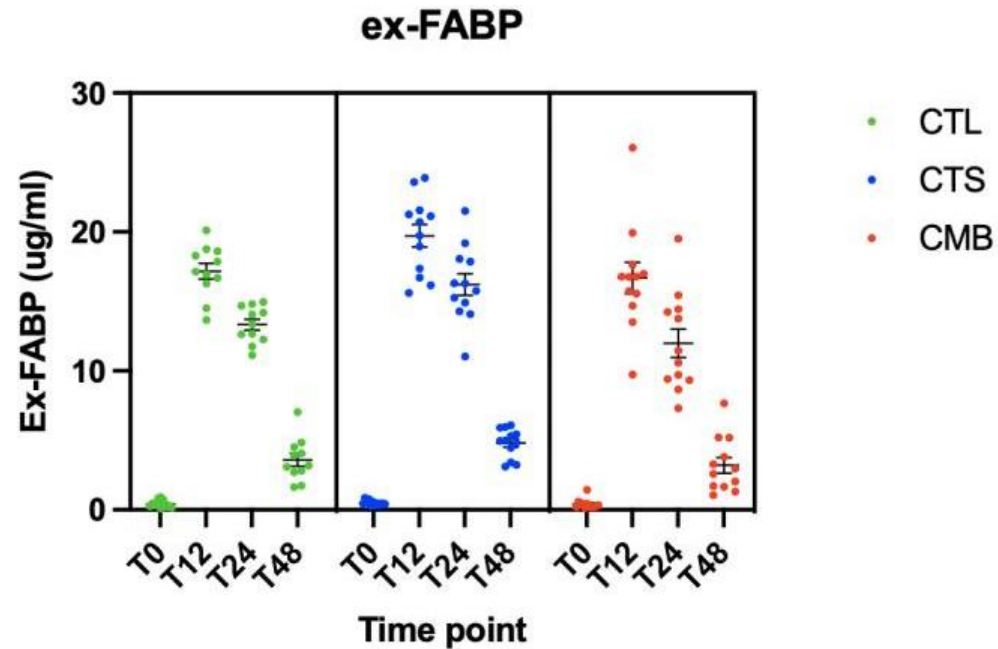

Figure 3.8 Table and scatter plot of Ex-FABP concentration based on different diets (CTL, CTS, CMB) pre (T0) and post (T12, T24, T48) challenge

The table indicates the number of samples (N), the mean and standard error of the mean (SE). Means that do not share a letter are significantly different. The data is also represented in the accompanying scatter plot. Ex-FABP levels significantly increase ($p < 0.001$) at all timepoints post challenge compared to T0h, peaking at T12h, while no significant differences were observed between CTL vs CTS and CMB diets at all time points. At T12h and T24h CTS showed higher ex-FABP abundance compared to CMB diet.

3.3.2.4 Plasma concentration of Hpx

The mean and SE of Hpx concentrations (ug/ml), pre and post LPS challenge (T0,12,24,48h) for each dietary treatment is presented in Figure 3.9. No significant interaction was found between diet and timepoint (post LPS challenge). Based on dietary treatment effects, no significant differences were found at any of the sampling time points. Diet therefore did not modulate this APP. LPS was found to significantly modulate the Hpx concentrations at all timepoints post LPS challenge compared to the normal physiological conditions pre challenge (T0h). Hpx increased ~5-fold and ~4-fold ($p < 0.001$) at T24h and T48h compared to T0h. LPS as the main effect on Hpx concentration over the time course of the study is presented in Figure 3.10.

		T0				T12				T24				T48			
	Diet	N	Mean	±	SE	N	Mean	±	SE	N	Mean	±	SE	N	Mean	±	SE
<i>Hpx</i> (<i>ug/ml</i>)	CTL	12	259.6	±	31.5 ^e	11	578.0	±	52.8 ^{de}	11	1263.6	±	61.4 ^{ab}	11	986.7	±	96.2 ^{bcd}
	CTS	12	304.7	±	30.5 ^e	12	667.1	±	53.3 ^{cde}	12	1547.0	±	149 ^a	12	1356.6	±	85.1 ^{ab}
	CMB	12	345.4	±	31.0 ^e	12	654.9	±	44.8 ^{cde}	12	1464.0	±	279 ^{ab}	12	1134.0	±	149.1 ^{abc}

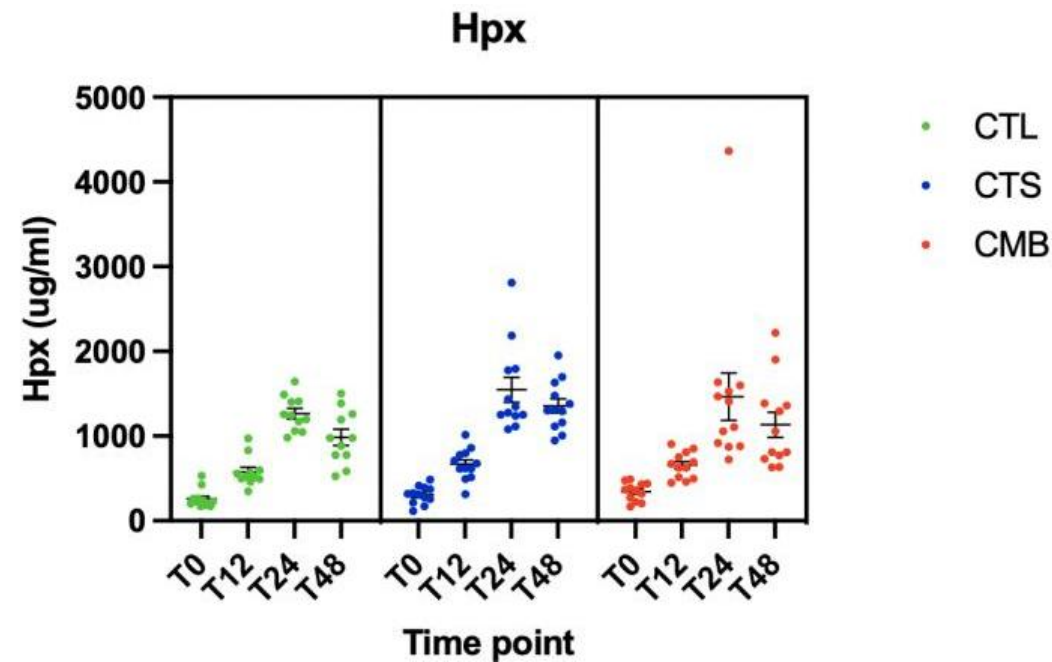

Figure 3.9 Table and scatter plot of Hpx concentration based on different diets (CTL CTS, CMB) pre (T0) and post (T12, T24, T48) challenge

The table indicates the number of samples (N), the mean and standard error of the mean (SE). Means that do not share a letter are significantly different. The data is also represented in the accompanying scatter plot. Hpx levels significantly increase at T24h and T48h post challenge ($p < 0.001$) compared to T0h while no significant differences were observed based on broilers diets at all time points.

	<i>Time point</i>	<i>N</i>	<i>Mean</i>	\pm	<i>SE</i>
<i>Hpx</i> (<i>ug/ml</i>)	0	36	303.24	\pm	18.4 ^a
	12	35	633.33	\pm	29.0 ^b
	24	35	1424.69	\pm	109.0 ^c
	48	35	1159.01	\pm	69.2 ^d

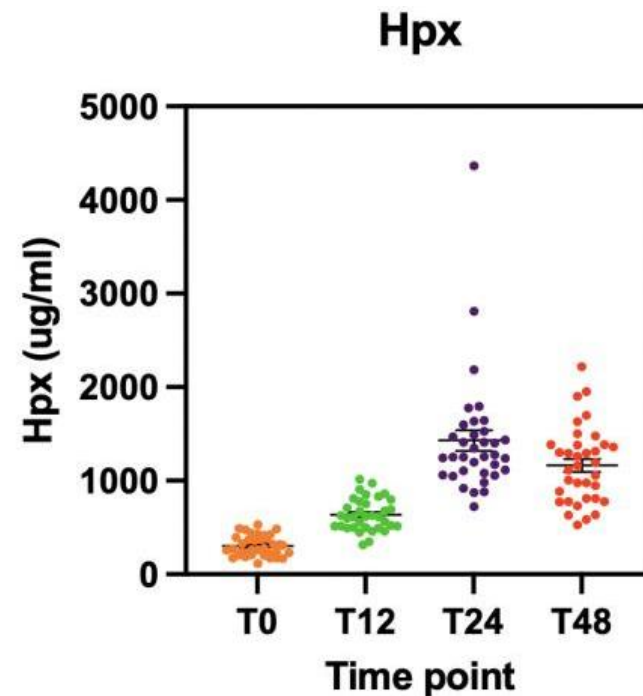

Figure 3.10 Table and scatter plot of Hpx concentration following LPS challenge at T0

The table indicates the number of samples (N), the mean and standard error of the mean (SE). Means that do not share a letter are significantly different. The data is also represented by the scatter plot. A significant increase ($p < 0.001$) of Hpx was found at all time points post challenge (T12,24,48h) compared to T0h pre challenge.

3.3.2.5 Plasma concentration of MRP-126

The mean and SE of MRP-126 concentrations (ng/ml) in broilers fed with the three diets (CTL, CTS and CMB) at all time points, pre and post LPS challenge (T0,12,24,48h), are summarised in Figure 3.11. No significant interactions between diet and LPS timepoint were found for this APP so the LPS challenge effect was investigated using the data set without considering the “diet” variable (Figure 3.12). MRP-126 was found to be significantly decreased at T24h ($p < 0.05$) compared to T0h and T12h; no differences between T12h and the other timepoints were observed. The concentration of MRP-126 at T24h post challenge was ~the half that measured at T0h.

		<i>T0</i>				<i>T12</i>				<i>T24</i>				<i>T48</i>			
	Diet	N	Mean	±	SE	N	Mean	±	SE	N	Mean	±	SE	N	Mean	±	SE
<i>MRP-126</i> (<i>ng/ml</i>)	CTL	12	543.0	±	103.0 ^a	11	381.5	±	79.1 ^a	11	434.0	±	106.0 ^a	11	807.0	±	172.0 ^a
	CTS	12	1007.0	±	136.0 ^a	12	760.0	±	233.0 ^a	12	433.0	±	120.0 ^a	12	1095.0	±	318.0 ^a
	CMB	12	898.0	±	266.0 ^a	12	614.0	±	158.0 ^a	12	382.7	±	80.4 ^a	12	846.0	±	159.0 ^a

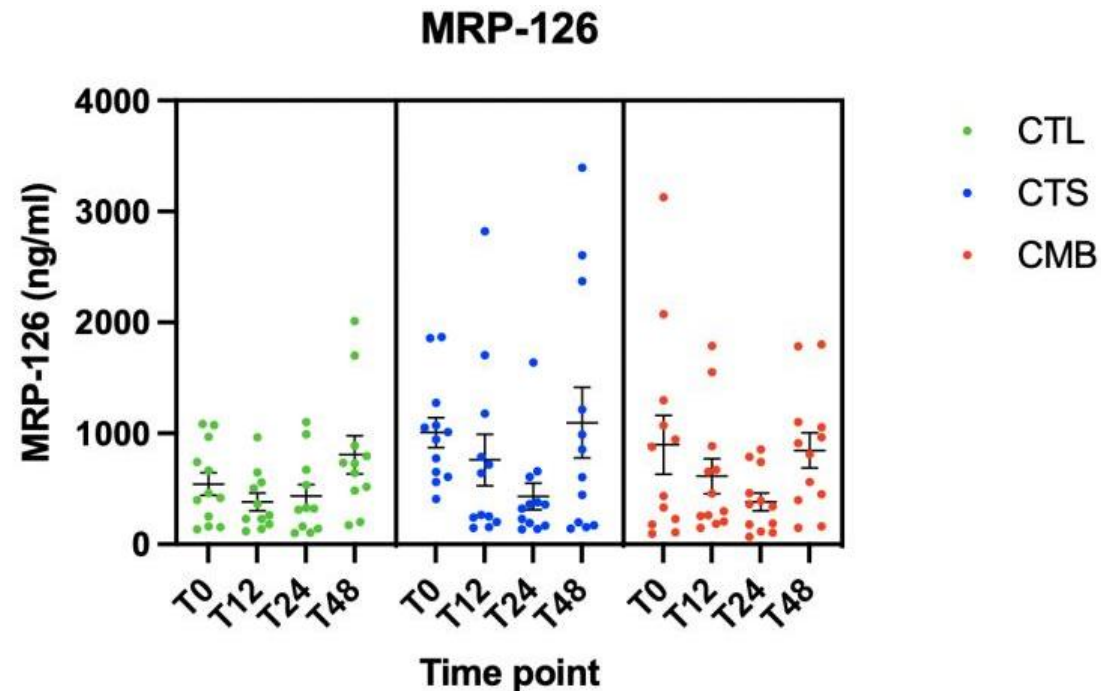

Figure 3.11 Table and scatter plot of MRP-126 concentration based on different diets (CTL CTS, CMB) pre (T0) and post (T12, T24, T48) challenge

The table indicates the number of samples (N), the mean and standard error of the mean (SE). Means that do not share a letter are significantly different. The data is also represented in the accompanying scatter plot. No significant differences in MRP-126 abundances were observed based on broilers diets and time points.

	<i>Time point</i>	<i>N</i>	<i>Mean</i>	\pm	<i>SE</i>
<i>MRP-126</i> (<i>ng/ml</i>)	0	36	816.0	\pm	108.0 ^a
	12	35	591.0	\pm	100.0 ^{ab}
	24	35	415.8	\pm	58.1 ^b
	48	35	919.0	\pm	131.0 ^a

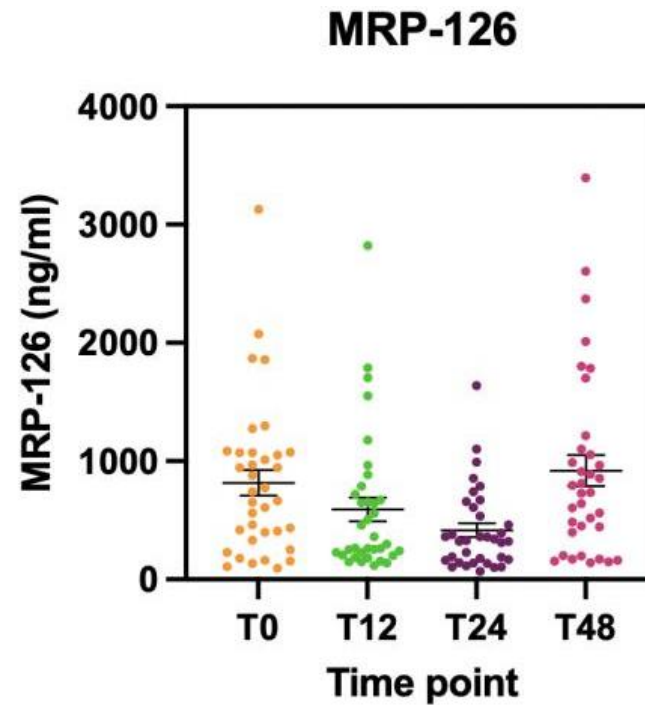

Figure 3.12 Table and scatter plot of MRP-126 concentration following LPS challenge at T0

The table indicates the number of samples (N), the mean and standard error of the mean (SE). Means that do not share a letter are significantly different. The data is also represented by the scatter plot. Significant decrease ($p < 0.05$) of MRP-126 was found at T24h post challenge compared to T0h pre challenge.

3.4 Discussion

The study in this chapter was aimed to compare the responses of two well established APPs (AGP and SAA) and three more novel APPs (Ex-FABP, Hpx and MRP-126) in broiler plasma following an LPS challenge and to test the hypothesis that the feed of broiler chickens, supplemented with citrus or cucumber extracts, has an immunomodulatory effect on the APR over a time course of 48h. The rationale for investigating dietary modulation of the APR by citrus or cucumber during an LPS challenge was based on previous studies which identified some plant compounds (e.g pectin, flavonoids, essential oils) that are able to influence the immune response of chickens (Ishisono et al., 2017; Ávila et al., 2021; Ebrahimi et al., 2015; Muhammad et al., 2019). In our study, disappointingly the dietary interventions did not appear to have a modulatory effect on either of these APPs when compared to the CTL diet yet increases in the two established APPs (AGP and SAA) at T12h and T24h post challenge confirmed that an APR had taken place. Similarly, the two novel APPs (Hpx and Ex-FABP), analysed using ELISA assays, responded to the LPS challenge, peaking at T24h for Hpx and T12h for ex-FABP with significant concentration increase of ~5-fold and ~17-fold respectively. A difference in AGP (T24h) and Ex-FABP (T12 and 24h) was detected when the CTS and CMB diets were compared but this seemed to be due to a number of outlier samples from broilers belonged to the same pen. The reason could be associated to their registered lower body weight that may have changed the APR and consequently the AGP and Ex-FABP abundance. The remainder of this discussion therefore focuses on the second aim which was to document the time course profile of our two novel APPs pre and post LPS challenge and to compare these to that of the more established APPs (SAA and AGP).

Ex-FABP has also been reported to increase in plasma in response to inflammation and tissue degeneration in chickens (Cermelli et al., 2010) and has been shown to influence cartilage, muscle cell differentiation and heart development (Gentili et al., 2005). Similarly, the study of Di Marco et al. (2003) observed that liver expresses the protein *in vitro* and LPS can enhance its expression; this suggests that liver overexpresses the protein during APR (Correnti et al., 2011).

Ex-FABP has also been shown to interact with fatty acids like oleic, linoleic and arachidonic acid but its mechanism of action has not yet been fully determined (Cancedda et al., 1996). The study of Simon et al. (2019) found that ex-FABP expression increases in chickens with altered intestinal morphology after fasting or following bacterial infection with the role to stimulate cell proliferation, tissue repair and defence of the host. Without Ex-FABP, chicken

liver cells show dramatic reduction in their ability to differentiate with increased apoptosis (Di Marco et al., 2003); These considerations and our results suggest that ex-FABP is a useful biomarker of early inflammation in broilers.

Irrespective of dietary treatments, Hpx concentration increased by around 5-fold post LPS challenge peaking at T24h. Hpx is a 60 kDa glycoprotein, mainly expressed in the liver tissue, that belongs to the family of APPs whose synthesis increases as a result of inflammation (Baumann and Gauldie, 1994). Hpx has been demonstrated to be an APP responsive to stress stimuli in chickens (O'Reilly and Eckersall, 2014). Hpx demonstrates high binding affinity to heme which is a highly toxic protein that can intercalate into lipid membrane and produce free radicals. The binding between heme and Hpx suggests that the role of Hpx is to act as a major vehicle of heme transportation in plasma thus preventing heme-mediated oxidative stress and heme-bound iron loss (Tolosano and Altruda, 2002). The observed increased Hpx level during the LPS response confirms its role as a useful biomarker of inflammation.

Data on the two established APPs, AGP and SAA, reported here, are similar to that previously reported by Horvatic et al. (2019). In their study these authors quantified the changes in the plasma proteome of broilers under similar challenge conditions and found that seven major proteins were significantly altered during the APR; among these SAA and AGP were upregulated post LPS injection. The current work confirms their findings: AGP significantly increases to reach a peak at 24h post LPS injection (~8-fold) but its level starts to increase (~4-fold) in the first 12h post injection and by T48h it still remains ~4-fold higher compared to T0h pre challenge. In their study Horvatic et al. (2018), found that AGP concentration was still significantly higher at 72h post LPS injection. This would mean that AGP requires considerable time in broilers to return to its baseline physiological level. Other similar studies predicted an increase of ~5-fold or more in serum due to inflammation (Takimoto et al., 2008); All these data are comparable to our findings and makes AGP a good biomarker of APR in broilers as its trend results to be well established and validated.

In this study SAA showed the great fold increase in concentration post LPS challenge compared to the other APPs although in terms of actual concentration SAA was the lowest reaching a peak of 3 mg/ml while Hpx had a concentration of 2mg/ml at its maximum level. During the first T12h post infection SAA reached a ~2000-fold increase, then it decreased rapidly at 24h to a level of ~30-fold higher than the baseline normal physiological conditions

(T0 and T48). These results are in accordance with those of Horvatic et al. (2019) and others (O'Reilly and Eckersall, 2014; Matulova et al., 2013) who have suggested that measuring SAA at T12 post challenge provides a more sensitive measure of the APR in broilers.

APPs	LPS peak	APP at the peak	Increased fold at the peak	APPs trend during APR	Restore after 48h
AGP	T24h	1.4 mg/ml	~8-fold	Slow increase and slow decrease (still high at T48h)	no
SAA	T12h	3 mg/ml	~2000-fold	Rapid increase and rapid decrease (T0,24 and 48h similar)	yes
Hpx	T24h	2 mg/ml	~5-fold	Slow increase and slow decrease (still high at T48h)	no
Ex-FABP	T12h	0.02 mg/ml	~20-fold	Rapid increase and slow decrease (still high at T24h)	not completely

Table 3.2 Comparison of novel and established APPs in plasma

AGP, SAA, Hpx and Ex-FABP were sampled from broilers subjected to a subcutaneous injection of *E. coli* LPS. The table indicates the LPS peak, concentrations, increased fold, trend and restore of each APP.

Table 3.2 compares the results of our two novel APPs (Hpx and ex-FABP) with established APPs (SAA and AGP) quantified by the study of (Horvatić et al. 2019). According to this data ex-FABP shows a similar early response to SAA post LPS challenge with an increase of ~20-fold in concentration at its peak which occurs at T12h post challenge. However, the concentration and the measured APR response is more sustained for ex-FABP suggesting that this protein might be a more useful biomarker to measure than SAA. AGP and Hpx both show a similar peak in response to LPS challenge. For these proteins the maximum response occurs at 24h post challenge with similar baseline concentrations, and a ~5-fold increase. Based on these comparisons, Hpx and ex-FABP are confirmed to be useful new biomarkers of APR in broiler chickens challenged with *E. coli* LPS. The knowledge generated in this experiment about these two novel biomarkers and their plasma concentration is extremely useful for those interested in studying the APR in broilers. The validation of the new diagnostic assays that have been developed and applied in this investigation could led to new strategies for monitoring the control of disease outbreaks in poultry.

MRP-126 was the only APP measured using the SPARCL™ assay. This APP has a similar behaviour to calgranulins which are produced by different tissues and then secreted into the blood and all seem to adopt a variety of roles to protect the host (Bozzi and Nolan, 2020). This characteristic makes MRP-126 different from the previous APPs which are produced by liver (O'Reilly and Eckersall, 2014). Our results suggest a significant decrease of this

protein at T24h compared to T0h. This result is in contrast with our expectations; MRP-126 levels were hypothesized to increase during LPS challenge conditions in broilers (Matulova et al., 2013). The study of Rychlik et al. (2014) suggests an increase of MRP-126 gene and protein expression in leukocytes lining the caeca level 4d after Salmonella Enteritidis infection. This could suggest that possibly the effects of LPS on MRP-126 can be observed after a certain period of time later than 48h post injection used in our study. MRP-126 has also been found to restrict the growth of certain microbes by sequestering Zn(II) in a Ca(II)-dependent manner in chickens (Bozzi and Nolan, 2020). Due to its role in modulating certain gut microbes, MRP-126 may be involved in localised responses to infection at the gut level and is more used locally and so not heavily released into the plasma so this could explain the decrease in its abundance observed in this study. Gut samples could be used to test and study this hypothesis. Other possible explanations are under investigation; MRP-126 levels could be evaluated by using an ELISA assay to compare the accuracy of SPARCLTM assay.

Conclusions

No dietary modulation of the APR by citrus or cucumber extracts was identified in this challenge experiment by observing the trend of novel and established APPs. However, in the next chapter of this thesis a proteomic investigation is carried out to determine if more subtle dietary effects can be detected in either the liver or muscle of broilers subjected to the same experimental conditions. The strongest APPs modulation observed at T12h and T24h post LPS injection will be considered as starting point for the proteomics investigation.

Based on our results and observations, Hpx and Ex-FABP, are considered as valuable biomarkers of APR in broilers; Ex-FABP showed a very strong response to LPS, comparable to SAA. Similarly, Hpx was comparable to AGP. SAA and Ex-FABP are therefore classified as major APPs while AGP and Hpx as moderate APPs.

These results indicate the trend of APPs after one single dose of LPS administered by intramuscular injection; it would be of interest to study their profiles in case of more continuous production of LPS/another bacterial mediator or changing the injection site. The knowledge generated about these novel biomarkers and their plasma concentration is extremely useful to study the role of proteins during APR in broilers. Their validation can contribute to science knowledge and led to new strategies for the control of disease outbreaks in poultry industry. Future studies with multiple exposure to the endotoxin or different

injection sites would be useful to get a clearer overall picture on their normal response to disease where one would expect the release of endotoxin to occur over a period of time.

Chapter 4 Proteomics on liver and muscle samples: effects of novel plant extracts following an LPS challenge

4.1 Introduction

Proteomics is the discipline aimed to study the sum of all proteins from an organism, tissue, cell or biofluid under specific or a defined set of conditions (Chandramouli and Qian, 2009; Bilić et al., 2018; Aslam et al., 2017). The field of proteomics has grown significantly in the last years, mainly due to improvements in the accuracy, sensitivity, speed and throughput of MS technology combined with the development of new software (Aslam et al., 2017). Nowadays, quantitative proteomic investigations can be performed on a range of tissues and body fluids including blood and tissues using either gel-based or gel-free methods (shotgun proteomics). The choice of methodology adopted depends on the aim of the study and the sample size (Abdallah et al., 2012) as discussed in chapter 1. In this chapter the liver and breast muscle are investigated using shotgun proteomics: the TMTplex labelling method has been coupled with tandem MS (LC-MS/MS) technology (see 1.8 Proteomics – chapter 1).

As previously discussed in chapter 3, Horvatić et al. (2019) investigated the plasma proteome of broilers subjected to an LPS challenge from *E. coli* and showed that several proteins were modulated during the first 12h post LPS injection including some established and novel APPs (SAA, AGP, Hpx) analysed in chapter 3. These proteins are generally synthesized by the liver, so it made worth to investigate their expression on the broiler's liver proteome. Moreover, liver regulates a range of physiological processes, including nutrient metabolism, immune function and lipid levels (Wu et al., 2021). The liver or hepatic proteome has been studied in broilers in relation to a range of metabolic conditions and diseases including heat stress and ascites and has also contributed to understanding the molecular basis of growth and fat deposition in different genetic lines (Wu et al., 2021). It is therefore apt to hypothesize that the hepatic proteome will observably react to inflammatory response under LPS challenge conditions. The liver is also the major organ involved in coordinating transitions relating to adaptations in carbohydrate, lipid and protein metabolism and it has been the subject of several proteomic investigations concerned with dietary modulation on growth and performance in livestock (Fonseca et al., 2019; Baldassini et al., 2018) but there is no studies on broilers. It is therefore reasonable to hypothesize that the liver proteome of broilers will be modulated in response to dietary supplementation which in turn could influence the broilers inflammatory response.

The intestinal proteome would be the other obvious target for investigation where the focus of attention is on dietary supplementation (Luo et al., 2013; O'Reilly, 2016), however there is also growing evidence that proteome changes in skeletal muscle underpin improved meat

quality and yield in livestock (Picard et al. 2010) and this includes broilers (Zheng et al., 2014). Under non-infectious inflammatory conditions Morales et al. (2015) showed that muscle atrophy occurs in mice leading to progressive loss in muscle mass and strength. Immunological challenge can also induce muscle fibre type conversion in piglets following an LPS challenge (Jia et al., 2015). The study of Doherty et al. (2004) demonstrated that the breast muscle of broilers offers an excellent system for proteomics investigation. Moreover, the study of Liu et al. (2015) has also proved that the mobilisation of skeletal muscle proteins during the immune stress response supplies the necessary amino acid precursors for the APP synthesis. In the context of our study, I hypothesise that the muscle proteome of broilers will react to LPS challenge and that dietary supplementation with CTS or CMB extracts modulates the muscle proteomes response to an immunological challenge.

4.1.1 Aims and Objective of the study

The main aim of the first proteomics study is to test the hypothesis that LPS challenge can modulate the liver and muscle proteome of broilers chickens in the first 12h post LPS challenge as indicated by the major APPs (SAA and Ex-FABP) analysed in the previous chapter. For this investigation tissues from CTL birds only were analysed.

To investigate the hypothesis that dietary supplementation with CTS or CMB extract modulate the proteome of liver and muscle to LPS challenge tissues collected from broilers on each dietary regimen were compared at T12 which corresponds to the peak of the APR response as defined by Horvatić et al. (2019) and by our own observations in chapter 3.

The knowledge generated from the first proteomics study, together with novel APPs and data from the partner university in Zagreb (Horvatić et al., 2019), will be valuable to define the role of LPS not only in plasma but also on liver and muscle proteome to identify novel biomarkers of toxicity. Then, if the hypothesis of the second objective is confirmed, this will add to the evidence base that dietary supplementation with CTS or CMB extract are valuable alternatives to the use of antibiotic growth promoters in broiler diets.

4.2 Materials and Methods

4.2.1 Proteomics: Summary workflow

Two proteomics studies were performed to evaluate both the effects of CTS and CMB vs CTL diets at T12h post LPS challenge, and the effect of LPS challenge during the first T12h post challenge in CTL, on the liver and muscle proteomes of broilers. The workflow followed for both proteomics studies was as follows: samples were extracted, quantified in their total protein concentration by bicinchoninic acid (BCA) assay and then processed by trypsin digestion using the filter assisted sample preparation (FASP) protocol and tandem mass tag (TMT) labelling. High resolution LC-MS/MS analysis of TMT-labelled peptides was performed and acquired MS/MS spectra were analysed for protein identification and quantification using the SEQUEST algorithm implemented into Proteome Discoverer (Figure 4.1). Statistical analyses were performed in RStudio. UniProtKB ID mapping tool and DAVID conversion tool were used to convert GI accession numbers into official gene symbol. Gene ontology enrichment analysis was performed using Protein Analysis Through Evolutionary Relationship (PANTHER) classification tool. These analyses were carried out at the University of Zagreb.

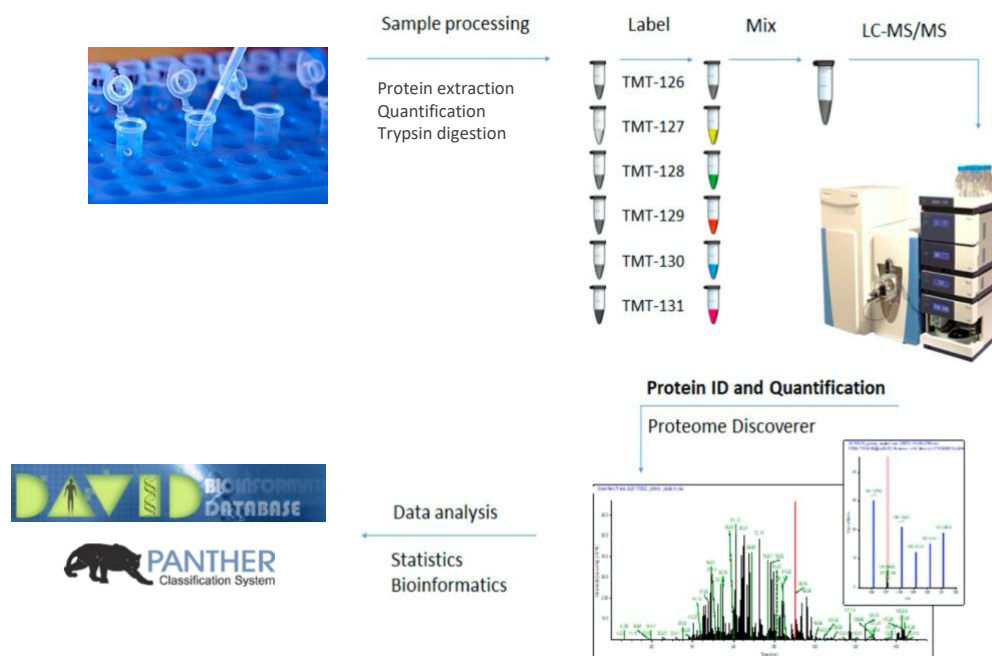

Figure 4.1 Samples preparation for protein quantification using Tandem mass Tag (TMT) plex and MS used for our proteomics investigation

Sample processing includes proteins extraction, quantification, trypsin digestion and TMT labelling, LC-MS/MS analysis of TMT-labelled peptides and the protein ID and quantification in Proteome Discoverer. Then, data analysis included the use of statistical and bioinformatic tools for proteome discoveries (e.g DAVID, PANTHER) (modified from A. Horvatić, MANNA summer school).

4.2.2 Sample selection and preparation

Both proteomics studies were carried out at the equipped laboratory facilities of the University of Zagreb, under the supervision of Prof. Vladimir Mrljak. In the first study liver and muscle samples belonging to CTL diet (5 samples at T0h pre challenge and 5 samples T12h post challenge/each tissue) were randomly selected from broilers in trial 2 and used for the analysis (Figure 4.2). In the second proteomics study, a total of 54 muscle and liver samples (9 samples/each diet/each tissue) were randomly selected and processed from broilers culled at T12h after LPS treatment in trial 2 (see experiment outlined in Chapter 3) (Figure 4.2). The number of samples was chosen based on the literature and previous evidence, from our team in Zagreb, to obtain valuable data for statistical evaluations. The samples of both studies had been stored frozen at -80°C prior to this preparation process. In both studies the same workflow was applied; 2/3 portions of tissue samples were first defrosted and homogenized in 300 ml lysis buffer (2% SDS in 0.1 M TEAB) (triethyl ammonium bicarbonate, TEAB, Thermo Scientific, Rockford, USA) using an Omni TH220 homogenizer (Omni International, Kennesaw, USA), followed by 2 cycles of sonication (2 times x 10 sec) at maximum amplitude (Qsonica, Newtown, USA) on ice. After centrifugation at 16 000 x g at 4°C for 20 minutes, the clarified supernatant was transferred into a new tube and stored at -80°C .

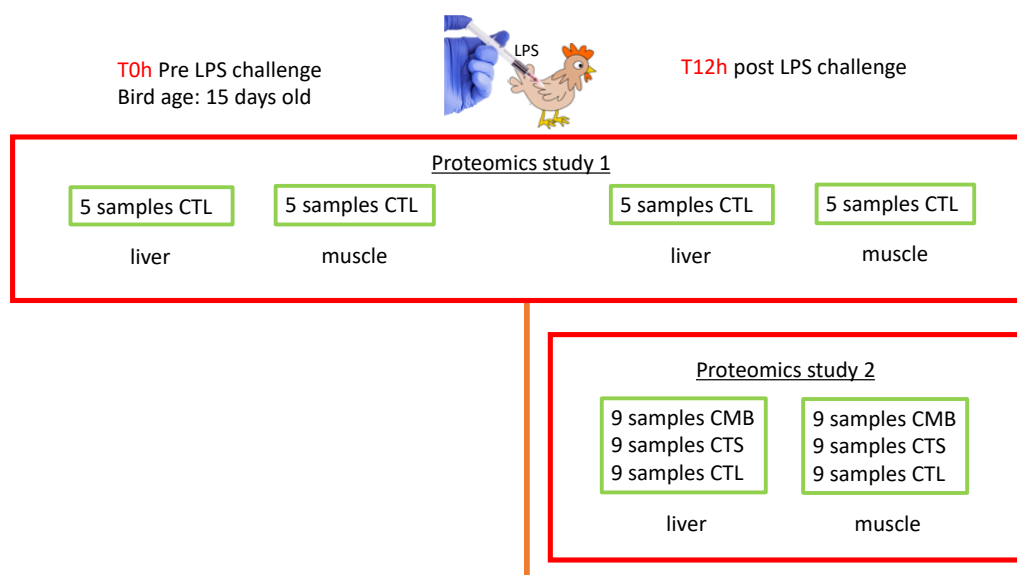

Figure 4.2 Samples used for proteomics study 1 and 2

In the first proteomics study, a total of 5 liver and 5 muscle samples from CTL diet at T0h pre challenge and T12h post challenge were chosen for the analysis. In the second proteomics study a 9 liver and 9 muscle samples at T12h post LPS injection were randomly selected from birds on each dietary regimen.

4.2.3 BCA assay

Total protein concentration in liver and muscle protein extract was determined using the Pierce™ BCA Protein Assay Kit (Thermo Scientific, Rockford, USA). The complex formed between protein and BCA reagent shows a strong absorbance at 562 nm and high protein concentration by comparison to a standard reference protein using bovine serum albumin (BSA). In our BCA assays, liver samples were diluted 100x time while muscle 50x time. The Blank and BCA standards were prepared using the working reagent (WB) (prepared by mixing 50 parts of A diluent + 1 part of B diluent) and making serial dilution of the BSA protein from 2 mg/mL to 25 µg/mL in concentration. All samples, standards and blanks run in duplicate on the microplate well (Thermo Scientific™ Pierce™ 96-Well Plates, Product No. 15041). 10 µL of each sample and 200ul of WB were added to each well and the plate was mixed on a plate shaker for 30 seconds. Then the covered plate was incubated at 37°C for 30 minutes, cooled at room temperature (RT) and the absorbance read at 630 nm on a plate reader. The standard curve was first checked to ensure our standard value concentrations coincide with the known values. The average value between all sample's duplicates was calculated, then the blank value was subtracted to all samples. The protein concentration was determined using a standard curve that was plotted according to the BSA standards (absorbance versus concentration in mg/ml) and the dilution factor. Based on the formula $y = mx + b$, all unknown sample's concentrations (x) were calculated. The Figure 4.3 showed the standard curves obtained from the first proteomics study. The equation $y = mx + b$ was generated by plotting the BSA concentration on the x axis and absorbance on the y axis (m and b values are generated from the linear line). Once the equation was obtained, the unknown protein concentration (x) was calculated.

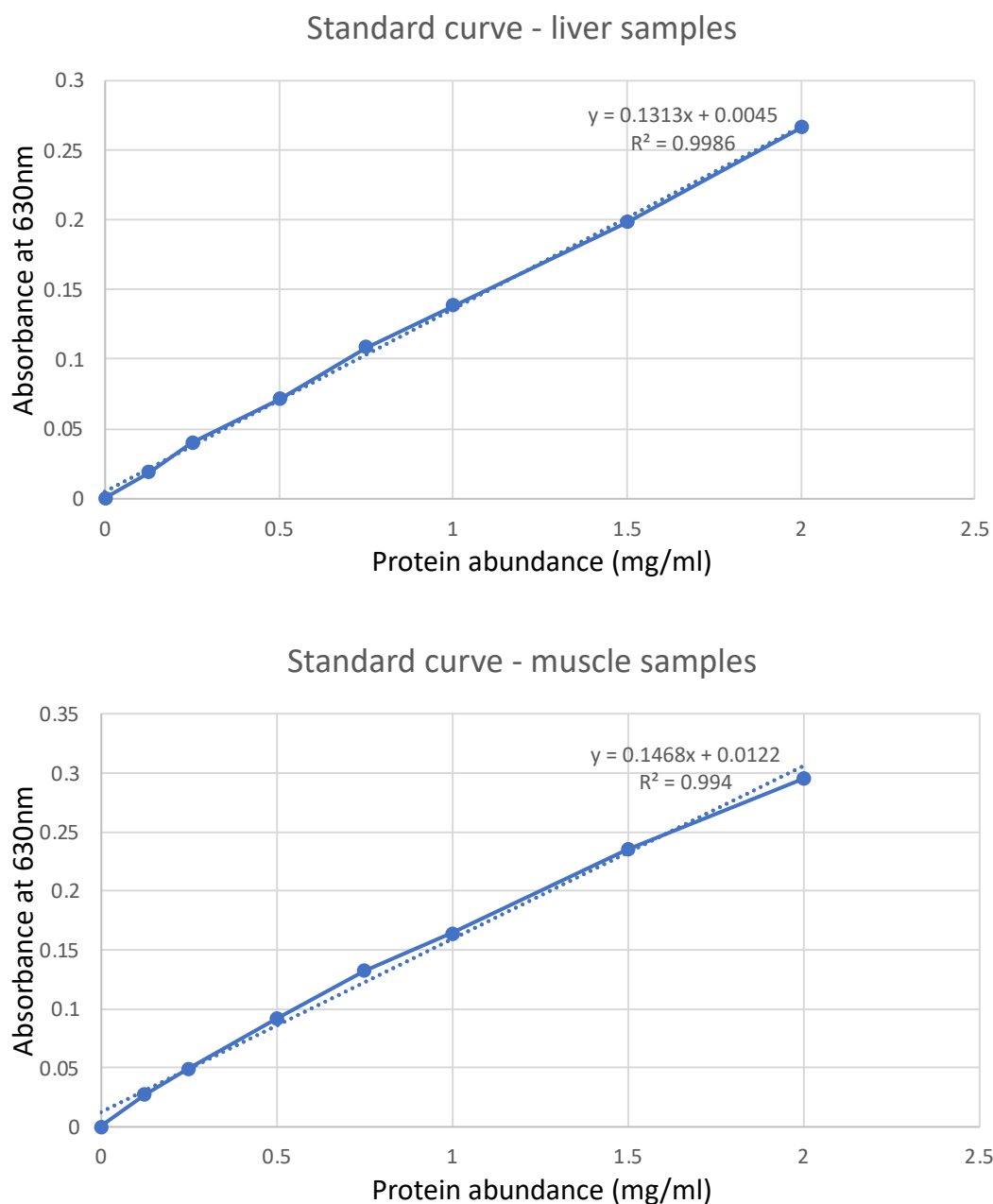

Figure 4.3 BCA assay: standard curves of liver and muscle samples of the first proteomics study

Scatter plot of the standard average values, subtracted by the blank, found from the BCA assays. In liver samples the slope is 0.1313 and y intercept 0.0045 while in muscle a slope of 0.1468 and intercept of 0.0122 is found. These standard curves are used to calculate the concentration of the unknown samples. R^2 represents the coefficient of determination.

4.2.4 FASP protocol

Sample extracts from each group were processed using the filter aided sample preparation (FASP) protocol. A detergent-free method was followed which comprises protein extraction with strong chaotropic reagents and protein precipitation and digestion under denaturing conditions. The main four steps of the FASP method includes: depletion of detrimental low-molecular-weight components in urea-containing buffer, carboamidomethylation of thiols,

digestion of proteins and elution of peptides (Zaefarian et al., 2019). An amount of 35 μg of total proteins for each sample was diluted to a volume of 200 μl using urea buffer (8 M urea in 0.1 M Tris-HCl pH 8.5) and subjected to the FASP protocol with some modifications. Internal standard (a pool of equal protein amount from all samples used as a reference for normalization) was processed following the same procedure as other samples, and it was used to compare relative quantification results between the experiments (TMT tenplexes). Samples were transferred to the 10-kDa membrane filter units (Microcon YM-10, Merck Millipore), centrifuged (13 000 \times g, 20 min, 20 $^{\circ}\text{C}$) and washed subsequently with 100 μl of urea buffer twice. Proteins were alkylated (50 mM IAA, 20 min at room temperature in the dark) (iodoacetamide, IAA, Sigma Aldrich, St. Louis, MO, USA), washed twice with urea buffer and then twice with TEAB (100 mM pH 8.5). Proteins were digested by trypsin gold (Promega, enzyme-to-protein ratio 1:35, v/v, at 37 $^{\circ}\text{C}$ overnight). Peptides were then collected from filter by centrifugation and washed with 50 μl of TEAB/ACN (1:1, v/v).

4.2.5 TMT labelling

The TMT labelling method enables multiplex relative quantitation by MS. Each mass-tagging reagent has the same nominal mass (e.g isobaric) and chemical structure. For each sample, a unique TMT label with a unique reporter mass is used to measure the expression of relative protein levels during peptide fragmentation. In both liver and muscle samples, TMT 10plex reagents (Thermo Scientific, Rockford, IL, USA) were prepared according to manufacturer's procedure. An amount of 19 μl of specific TMT label (127c, 127n, 128c, 128n, 129c, 129n, 130c, 130n, 131) was added to each sample for labelling (60 min, room temperature). The reaction was quenched using 5% hydroxylamine (Sigma-Aldrich, St. Louis, MO, USA). Nine TMT-modified samples were randomly combined with the internal standard, aliquoted and dried before proceeding with LC-MS/MS analysis. An example of this procedure, using TMT sixplex, is described in the Figure 4.4.

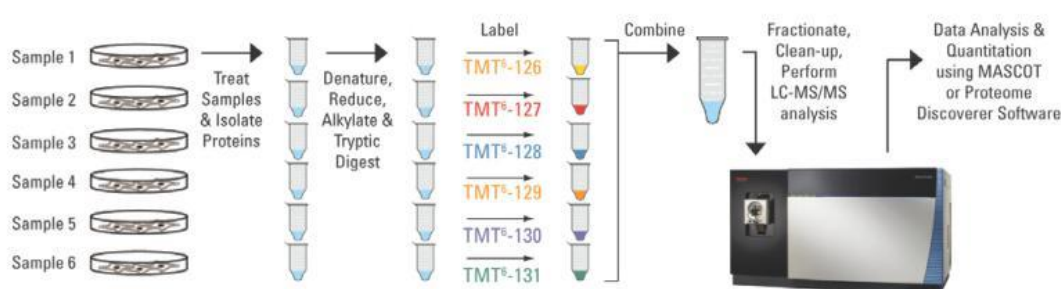

Figure 4.4 Example of workflow summary using the Thermo Scientific TMT sixplex Isobaric Mass Tagging Reagents

(<https://www.thermofisher.com/order/catalog/product/90061>).

4.2.6 LC-MS/MS analysis

High resolution LC-MS/MS analysis of TMT-labelled peptides was performed using an Ultimate 3000 RSLCnano system (Dionex, Germering, Germany) coupled to a Q Exactive Plus mass spectrometer (Thermo Fisher Scientific, Bremen, Germany) (Horvatić et al 2019). Peptides were dissolved in loading solvent (2% ACN, 0.1% formic acid) and loaded onto the trap column (C18 PepMap100, 5 μm , 100A, 300 $\mu\text{m}\times 5\text{ mm}$), desalted for 12 min at the flow rate of 15 $\mu\text{L}/\text{min}$ and separated on the analytical column (PepMapTM RSLC C18, 50 $\text{cm}\times 75\text{ }\mu\text{m}$) using a linear gradient of 5–55% mobile phase B (0.1% formic acid in 80% ACN) for 120 min. Mobile phase A consisted of 0.1% formic acid in water. Ionisation was achieved using nanospray Flex ion source (Thermo Fisher Scientific, Bremen, Germany) containing a 10 μm -inner diameter SilicaTip emitter (New Objective, USA). The MS operated in positive ion mode using DDA Top8 method. Full scan MS spectra were acquired in range from m/z 350.0 to m/z 1800.0 with a resolution of 70,000, 120 ms injection time, AGC target 1×10^6 , a ± 2.0 Da isolation window and the dynamic exclusion 30 s. HCD fragmentation was performed at step collision energy (29% and 35% NCE) with a resolution of 17,500 and AGC target of 2×10^5 . Precursor ions with unassigned charge state, as well as charge states of +1 and more than +7 were excluded from fragmentation. Acquired MS/MS spectra were analysed for protein identification and quantification using the SEQUEST algorithm implemented into Proteome Discoverer (version 2.3., ThermoFisher Scientific). Database search against *Gallus gallus* FASTA files (downloaded from Uniprot database on January 29th 2020, 48387 sequences) was performed according to the following parameters: two trypsin missed cleavage sites, precursor and fragment mass tolerances of 10 ppm and 0.02 Da, respectively; carbamidomethyl (C) fixed peptide modification, oxidation (M), and TMT tenplex (K, peptide N-terminus) dynamic modifications. The false discovery rate (FDR) for peptide identification was calculated using the Percolator algorithm in the Proteome Discoverer workflow based on the search results against a decoy database and was set at 1% FDR. At least two unique peptides and 5% FDR were required for reporting confidently identified proteins. Protein quantification was accomplished by correlating the relative intensities of reporter ions extracted from tandem mass spectra to that of the peptides selected for MS/MS fragmentation.

4.2.7 Statistical analyses

Statistics was performed using R (v4.0.0) under RStudio, “plyr”, “dplyr”, “gplots”, “EnhancedVolcano” packages were used for data manipulation, statistics, and graphic visualizations. The effect of LPS challenge on 1) the liver and 2) the muscle proteome was studied using Student’s T-test (CTL_T0h vs CTL_T12h in the first proteomics study; The effect of dietary modulation on the immune response was also studied using Student T-Test (CTL_T12h vs CTS_T12h and CTL_T12h vs CMB_T12h) in the second proteomics study. Based on Student T-test results, statistical significance was set at $p < 0.05$. Fold change (fc) was calculated by the formula $\text{Mean(CTL_T12)}/\text{Mean(CTL_T0)}$ in the first proteomics study and $\text{Mean(CTS_T12)}/\text{Mean(CTL_T12)}$ or $\text{Mean(CMB_T12)}/\text{Mean(CTL_T12)}$ in the second proteomics study. Log of fc, between the 2 groups, was been calculated by the function $\log(2)fc$. The distribution of the differentially expressed proteins (e.g those up or downregulated,) by both $\log(2) fc$ vs. $\log(10) p$ was studied through volcano plots. Heatmaps of the statistically significant proteins were generated using the ward.D hierarchical clustering method. Heat maps allowed the identification, by different colours, the proteins that were up and down regulated in each group and their level of phylogenetic similarity.

4.2.8 Gene Ontology Enrichment Analysis

For functional annotation, proteins’ GI accession numbers were first converted into official gene symbol either by UniProtKB ID mapping tool (<https://www.uniprot.org/uploadlists/>) or DAVID conversion tool (<https://david.ncifcrf.gov/conversion.jsp>) based on the Gallus Gallus database. Gene ontology (GO) classification was performed using Protein Analysis Through Evolutionary Relationship (PANTHER) classification tool (<http://www.pantherdb.org/>) with subset of GO terms (GO Slim database). The classifications were again performed using the *Gallus Gallus* database. Molecular functions, biological processes, cellular components, protein classes and Kegg pathways were studied.

4.2.9 Validation of selected differentially expressed Proteins by the Western Blot procedure

The validation of selected proteins was performed through the Western Blot (WB) procedure for both liver and muscle samples focusing on interesting proteins discovered across the two proteomics investigations for which commercial antibodies were readily available: Heat

Shock protein 90 (Hsp90), Lactate Dehydrogenase (LDHA) and Glyceraldehyde-3-Phosphate Dehydrogenase (GAPDH). The WB procedure includes preparation of samples by homogenization, BCA assay to determine protein's concentrations and gel electrophoresis (each step is described in the sections below).

4.2.9.1 Sample homogenization

For Western blot analysis, 100 mg of each sample (N=9/diet and time point) were homogenized through the Kinematica™ Polytron™ PT1200E handheld homogenizer (Thermo Fisher Scientific) in 1ml of buffer (1mM EDTA, 50 mM Tris-HCl pH 7.4 and protease inhibitor cocktail 100x), centrifuged at 4°C for 10 mins at 1000g, the supernatant removed and aliquoted into 200ul batches for either immediate use or for storage at -80oC for later use.

4.2.9.2 BCA assay

The BCA assay was used to determine the concentration of proteins in each sample following the recommended procedure; once the concentration of each sample was determined, samples were diluted in Milli-Q (MQ) water to obtain a final protein concentration of 2mg/ml.

4.2.9.3 Gel electrophoresis

20ug of sample were mixed with MQ water and SB (250ul 4x lemnini + 50ul DTT) to reach a total volume of 24ul. 3 ul of PageRuler Plus Prestained Protein Ladder (ThermoFisher Scientific, cat no. 26619) and 10 ul of each prepared sample were loaded into the Criterion™ XT Precast Gel 4-12% bis-tris 26 wells comb (Bio-Rad, USA). For this gel the XT MES running buffer (Bio-Rad, USA) was used to rinse the electrophoresis unit. In liver WB, I used a total of 20 wells in each gel (18 samples + 2 ladders) to compare, in a total of four gels, CTL T0 vs CTL T12 (gel 1), CTL T0 vs CTS T0 (gel 2), CTL T12 vs CTS T12 (gel 3), CTS T0 vs CTS T12 (gel 4) with the aim to demonstrate that the proteins Hsp90 and LDHA were modulated by LPS and/or CTS diet in the first 12 hours post challenge. All possible comparisons were considered in the gels as enough antibodies for both proteins were available. In muscle WB, due to time constrains, I focused on the effect of CTS diet on the abundance of GAPDH (key finding of our proteomics investigation), by comparing CTL T12 vs CTS T12 in the same gel with 20 wells (18 samples + 2 ladders).

For all gels, the electrophoresis machine was set to 140V and run for 1 hour. The running of the gels was checked periodically to make sure that the dye front did not run too far down the gel. Once completed, the rig and gels were put under a running tap water tap (buffer solution contains salt so it's important to rinse the electrodes). The mixture of proteins was separated based on molecular weight which are represented by protein bands of various size on the gel.

4.2.9.4 Transferring procedure

Gels were then transferred on the iBlot™ Transfer stack (ThermoFisher Scientific, cat no. IB401031) for the transferring procedure. iBlot® Dry Blotting System (Invitrogen, can no. IB1001UK) was used to complete the transfer of proteins (7 minutes) from the gel to the cellulose nitrate membranes. The newly transferred blot was placed in Ponceau S. dyed and shaken gently for 5 minutes. This allowed the proteins to be visualised to ensure correct loading of wells and transfer to membrane. Then membranes were washed with MQ and Tris buffer saline (TTBS) to remove dye. The membranes were blocked in 5% dried milk (Marvel) solution for 1 hour at RT on a shaker.

4.2.9.5 Antibody incubation and ECL

Primary antibodies were prepared according to the manufacturer or optimized protocol procedures. In liver WB, the Rabbit polyclonal Anti-Lactate Dehydrogenase (LDHA) (Abcam, cat no. 130923) and the Rabbit Anti-Heat Shock protein Hsp 90-alpha (Rockland antibodies and assays, cat no. 600-401-929) antibodies were used. The anti-LDHA was diluted 1:2000 while anti-Hsp90 1:1000.

In muscle WB, the Anti-GAPDH (GA1R) (Abcam, cat no. 125247) was used and diluted 1:4000. Each antibody made up in 5% dried milk (Marvel) was incubated with blots overnight and washed three times in TTBS. Blots were then incubated for 1.5 hour at RT in relevant secondary antibodies made up in 5% marvel (Donkey anti Rabbit HRP (Abcam, cat no. 205722) 1:10000 for liver samples and Goat anti-Mouse (Abcam, cat no 6708) 1:5000 for muscle samples) and washed with TTBS. The ECL Reagent (ThermoFisher, cat no. 32106) (1.5 ml for 2 blots) was added, and blots were then wrapped in transparent films and placed on an x-ray cassette. Each blot was read in the dark room and an X-ray film representing the band of desired protein obtained. Multiple exposures times were tried for both antibodies, but the best result was obtained at 30 seconds for LDHA, 3 minutes for

Hsp90, 1 minute for GAPDH. The expected molecular weights for each protein were: 90 kDa for Hsp90, 35kDa for LDHA, 37 kDa for GAPDH.

4.2.9.6 Statistical analysis

The bands area referred to as the antibody abundances of each sample was calculated using NIH ImageJ software (Wilson et al., 2018; Ferreira and Rasband, 2012). Peak intensity area of each sample was recorded, and statistical analysis performed by Graphpad Prism v.9.1 (GraphPad Software, San Diego, USA). The unpaired T-test (two-tailed) was used to study the abundance of LDHA and Hsp90, by comparing the means and standard deviations of samples of the following comparisons: CTL T0 vs CTL T12, CTL T0 vs CTS T0, CTL T12 vs CTS T12 and CTS T0 vs CTS T12. The abundance of GAPDH was studied as well, using the same approach and statistical analysis but only in CTL T12 vs CTS T12 (see section 4.2.9.3).

4.3 Results

4.3.1 Summary of the effects of LPS on the liver and muscle proteome (CTL diet at T0h vs T12h)

A total of 3114 proteins were identified and quantified by the label-based quantitative proteomic approach in the liver. By comparing CTL T0h vs CTL T12h, 1243 proteins belonging to set criteria (2 unique peptides and 5% FDR) were identified from Proteome Discoverer: 87 proteins displayed differential abundances at T12h post LPS injection ($p < 0.05$) with 36 proteins associated to unique gene names (24 proteins higher abundances and 12 lower abundances). In muscle samples, a total of 1399 proteins were identified and quantified with 668 of these belonging to set criteria (2 unique peptides and 5% FDR) when comparing CTL T0h vs CTL T12h. Only 1 protein was found to be upregulated by LPS challenge at T12h (Table 4.1).

	Tot. proteins identified	Proteins (2 unique peptides and 5% FDR)	Proteins ($p < 0.05$) associated to unique genes	Proteins increased by LPS	Proteins decreased by LPS
Liver	3114	1243	36	24	12
Muscle	1399	668	1	1	0

Table 4.1 Effects of LPS at T0h vs T12h post LPS challenge in the CTL diet

The table indicates the total number of proteins identified in liver and muscle samples and the subsequent filtering steps used for the analysis. Respectively from the left column to the right: proteins with a minimum number of 2 unique peptides and 5% FDR, total number of proteins associated to unique genes which showed significant difference ($p < 0.05$) based on LPS challenge and the proteins significantly increased and decreased by LPS.

4.3.1.1 Effect of LPS on the liver proteome (CTL diet at T0h vs T12h)

In liver samples, the 36 proteins related to unique genes (24 higher abundances and 12 lower abundances) as specified above, were investigated. A description of these protein, their unique gene name, differential median abundance (relative to internal standards in proteome discoverer) for each time point, fc and the relative p is provided in Table 4.2.

Volcano plots (Figure 4.5) were used to study the distribution among the differentially expressed proteins comparing the $\log fc$ ($-0.2 < \log fc < 0.2$) vs. $\log p$: isoforms of actin and fibrinogen and metabolic enzymes were identified to be significantly upregulated at T12h post LPS challenge (right green dots in Figure 4.5).

Heat maps showed the distribution of significant proteins ($p < 0.05$) among samples of the same group; at T0h there was a higher consistency while higher variability was discovered in samples at T12h with one particular sample showing a strong diversity compared to others in the same group (Figure 4.6). Note: excluding this sample from our statistical analysis removed the observed effects on the abundance of actin and fibrinogen. However, no evidence in the trial records for excluding this sample was found to justify removal of this sample so the full dataset is presented.

Accession ID	Description	Gene name	Unique peptides	MedianCTL_T0	MedianCTL_T12	fc	Log fc	<i>p</i>
1730518	Phosphoglycerate kinase	PGK1	3	525.4	485.0	0.923	-0.115	0.002
211711	cytochrome P450	CYP2C23a	5	842.3	640.4	0.760	-0.395	0.002
117258	Cytochrome P450	CYP2C23b	4	842.3	640.4	0.760	-0.395	0.002
1390126179	hydroxymethylglutaryl-CoA synthase	HMGCS1	3	522.2	755.7	1.447	0.533	0.002
971381973	protein disulfide-isomerase	PDIA4	6	880.1	1042.2	1.184	0.244	0.003
766944282	albumin	ALB	4	690.8	583.1	0.844	-0.245	0.003
971434955	alpha-2-macroglobulin	A2ML4	6	1153.9	1386.0	1.201	0.264	0.004
755815	complement C3	C3	8	1132.7	1453.7	1.283	0.360	0.006
383087734	ribosome-binding protein 1	RRBP1	7	990.6	1099.0	1.109	0.150	0.007
971439575	clathrin	CLTA	2	310.5	370.4	1.193	0.254	0.009
125961	Lamin A	LOC396224	6	1424.7	1106.7	0.777	-0.364	0.009
14579649	heat shock protein 90	HSP90B1	9	2658.9	2947.7	1.109	0.149	0.012
61611929	visfatin	NAMPT	2	731.9	910.1	1.243	0.314	0.015
211827	heat shock protein 70	HSPA5	8	1917.6	2182.7	1.138	0.187	0.016
53131920	hypothetical protein	HARS	2	166.3	141.5	0.851	-0.233	0.019
1160421733	Aminopeptidase N	ANPEP	6	1001.3	865.6	0.864	-0.210	0.019
46519238	complement C3 precursor	C3	2	532.1	605.8	1.139	0.187	0.020
392018	filamin	FLNB	4	813.2	894.2	1.100	0.137	0.023
25091747	KH type-splicing regulatory protein	KHSRP	3	416.5	454.0	1.090	0.124	0.024
63389	fibroblast alpha actinin	ACTN1	3	709.1	761.6	1.074	0.103	0.025
1390080163	acyl-CoA synthetase family	ACSS2	3	925.3	856.1	0.925	-0.112	0.028
1390106302	fibrinogen	FGB	2	328.9	400.3	1.217	0.283	0.028

1390070558	Filamin B	FLNB	6	900.3	999.0	1.110	0.150	0.029
226450	cytochrome b5	CYB5A	2	255.2	203.9	0.799	-0.324	0.030
971432776	tropomyosin	TPM3	2	623.1	683.5	1.097	0.133	0.030
1172808	Ribosomal protein L10	RPL10L	2	447.0	480.3	1.074	0.104	0.030
60302774	T-complex protein	CCT5	2	451.9	522.2	1.156	0.209	0.031
1482417173	Actin	ACTA2	2	228.9	308.8	1.349	0.432	0.034
55976646	Actin	ACTA1	2	228.9	308.8	1.349	0.432	0.034
8569622	Fibrinogen	FGB	3	844.1	990.0	1.173	0.230	0.035
53130414	hypothetical protein RCJMB04_7j3	ARCN1	3	1011.6	1079.3	1.067	0.093	0.037
157830870	Dihydrofolate reductase	DHFR	2	407.7	391.9	0.961	-0.057	0.037
619534144	aminolevulinate dehydratase	ALAD	4	820.3	762.4	0.929	-0.106	0.041
971402751	glutathione S-transferase	GSTO1	2	636.0	574.4	0.903	-0.147	0.041
8569626	Fibrinogen	FGG	3	681.1	864.1	1.269	0.343	0.044
63516	Heat shock protein 90	HSP90AA1	10	2787.7	2908.3	1.043	0.061	0.046

Table 4.2 Differentially expressed proteins ($p < 0.05$) at T0h vs T12h in liver samples collected from CTL diet pre and post LPS injection

List of significant proteins (N=36) associated to unique genes with the relative median at both timepoints (abundance score relative to internal standard from proteome discoverer), fc, Log fc and p. Proteins are listed in order of increasing p.

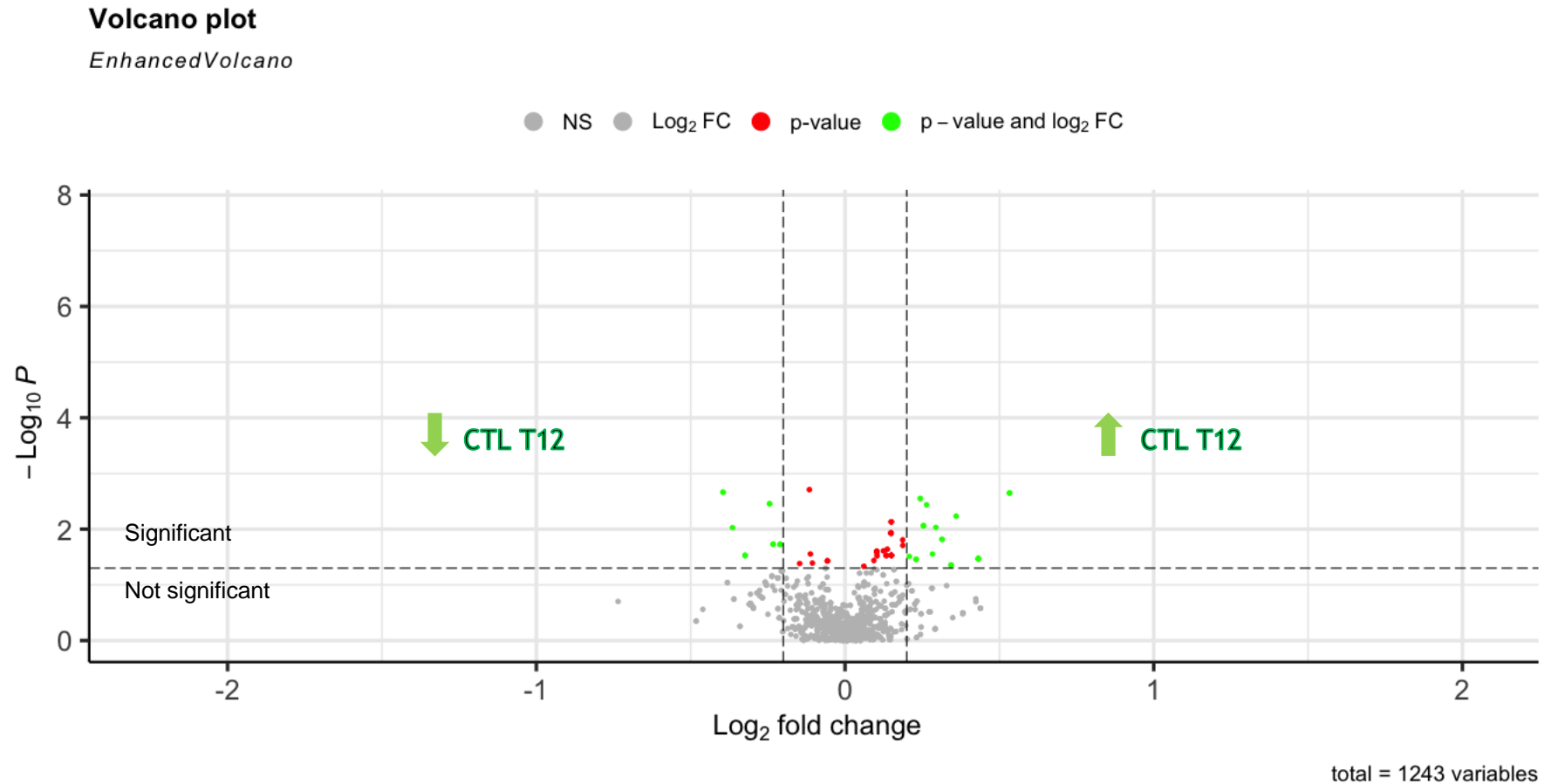

Figure 4.5 Volcano plots comparing liver proteome at T0h and T12h post LPS challenge

Proteins belonged to CTL diet at 0h (CTL_T0) and T12h (CTL_T12) post challenge. Green dots represent proteins upregulated ($\log p > 1.3$ and $\log fc < -0.2$) and downregulated ($\log p > 1.3$ and $\log fc > 0.2$) by CTL T12h (12h post LPS challenge). Red dots represent are proteins ($p < 0.05$) regulated just by the $\log p$. Grey dots indicate no significant proteins by both $\log p$ and $\log fc$ (NS) or by $\log p$.

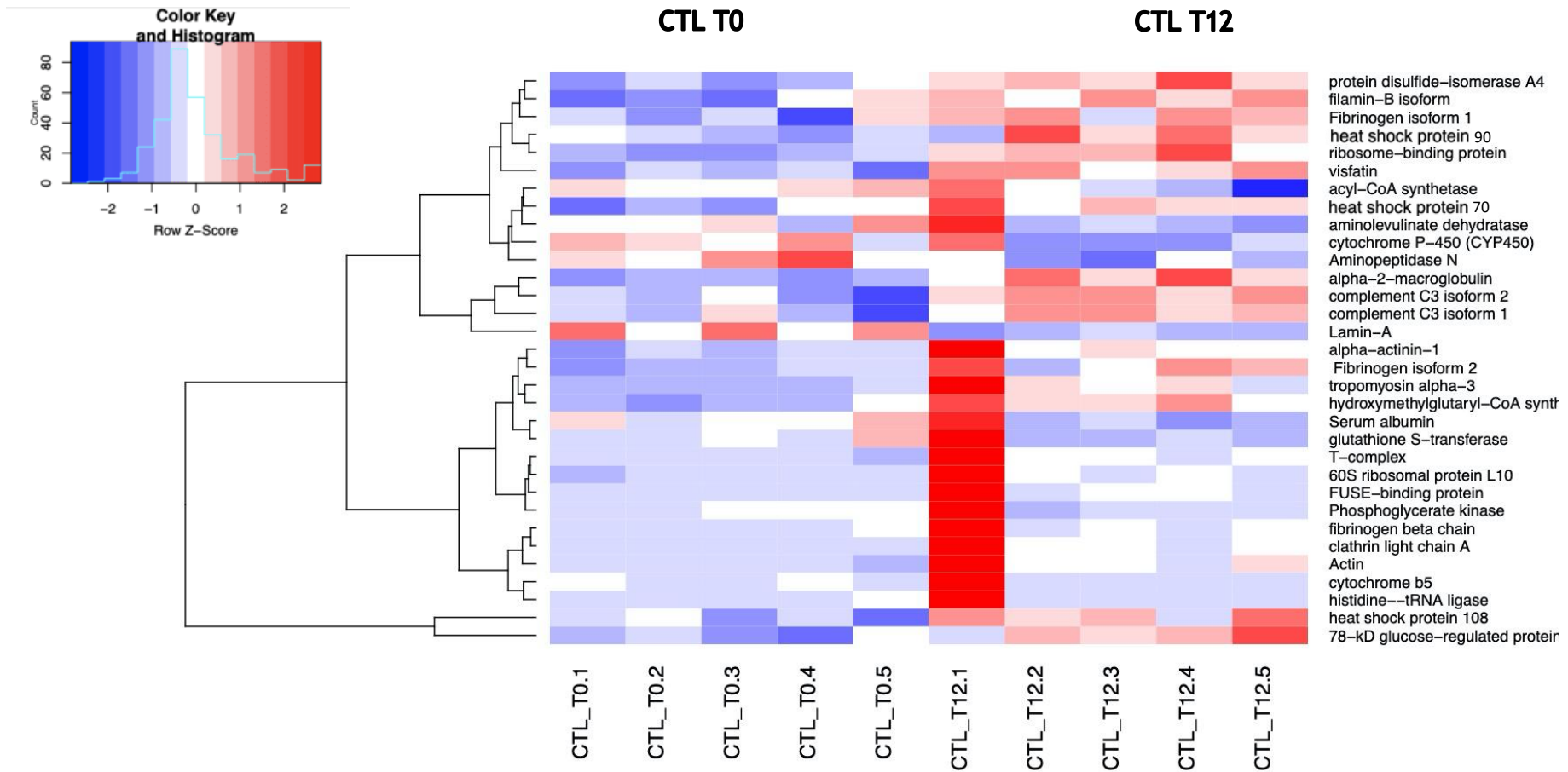

Figure 4.6 Heat maps of liver proteome in samples collected at T0h and T12h post LPS challenge

Heat map of significant proteins ($p < 0.05$) associated to unique genes identified in CTL_T0 vs CTL_T12 diet. Samples in CTL_T0 diet showed higher consistency compared to CTL_T12;

Note: Sample CTL_T12.1 was found to have a strong diversity compared to the other samples. The name of each significant protein is indicated on the right.

Ontology investigation using the GO Slim analysis in PANTHER GO resource was used to study molecular functions and biological processes of the liver proteins that were differentially abundant based on LPS challenge. In the study of molecular functions, proteins were mainly associated with binding activity (15 genes) and catalytic activity (9 genes), while a minority were associated with structural activity (2 genes) (Figure 4.7). Among those associated with binding activity, most proteins were involved in heterocyclic compound binding, organic cyclic compound binding (8 genes) and protein binding (8 genes) while among catalytic activity, the majority of proteins were involved in oxidoreductase reactions in metabolic pathways. Regarding structural activity, actin was identified to be upregulated by the LPS challenge (this upregulation is mainly attributed to one sample – see Figure 4.6). In terms of biological process most proteins were found to be involved in cellular process (18 genes) and includes proteins such as Hsp families (Hsp90 and Hsp70) and actin (Figure 4.7).

In this investigation, the key proteins modulated by LPS challenge at T12h post injection are represented by Heat shock proteins (Hsp90 and Hsp70) which were found increase post LPS injection.

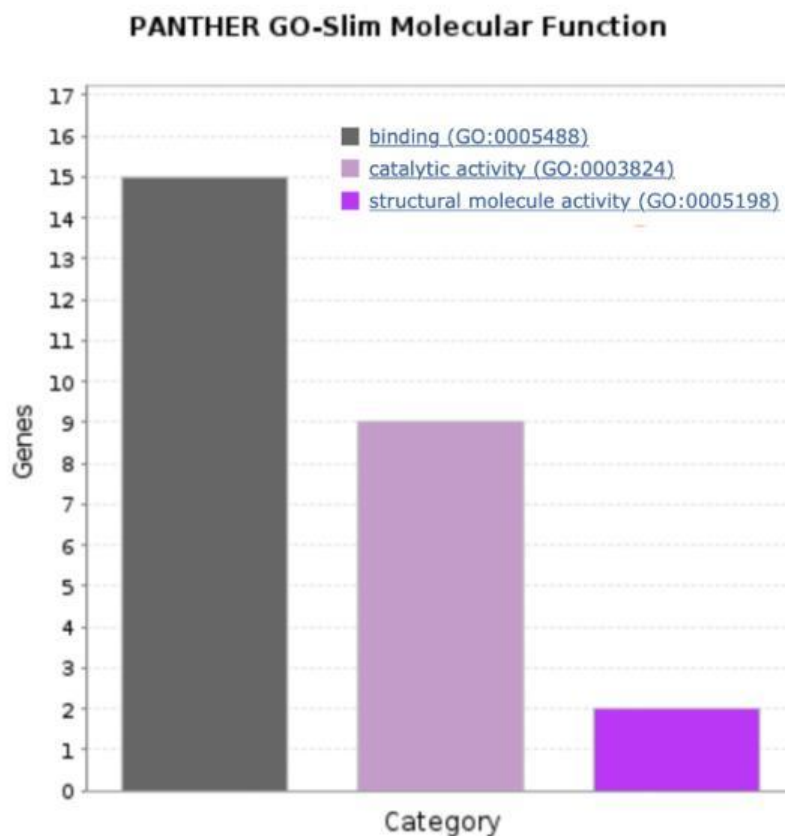

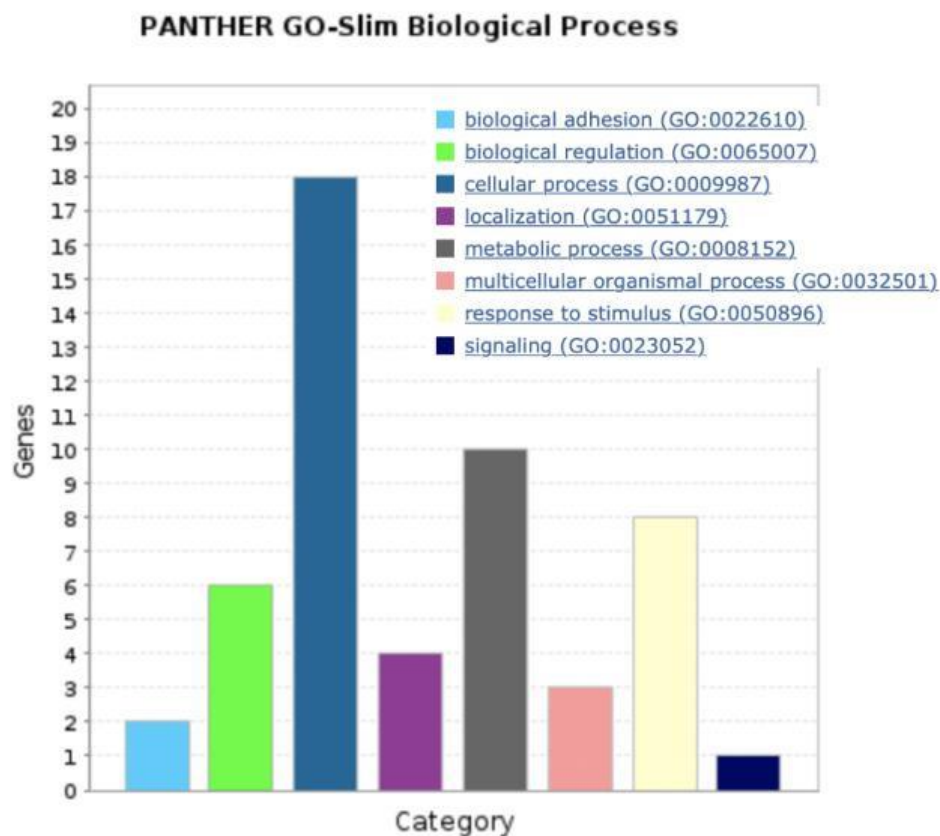

Figure 4.7 GO slim analysis of differentially expressed liver proteins at T0h and T12 post LPS challenge

The x-axis unit of percentage (%) is the number of genes in GO term. Molecular functions and of biological process are represented.

4.3.1.2 Effect of LPS on the muscle proteome (CTL diet at T0h vs T12h)

In muscle samples, 1399 proteins were identified and quantified by the label-based quantitative proteomic approach. Among these, 668 proteins belonging to set criteria (2 unique peptides and 5% FDR) were identified from Proteome Discoverer but just 1 protein (kelch-like protein) showed significantly higher abundance following LPS challenge ($p < 0.05$). Based on these finding data, no further investigations were conducted in observing changes due to LPS challenge in muscle sample.

4.3.2 Effect of diets on the liver and muscle proteome at T12h post challenge

The effects of dietary treatments (CTS and CMB) on the liver and muscle proteome were investigated. CMB diet did not show relevant results in relation to either the immune response or metabolism when compared to CTL diet at T12h post LPS challenge. For this reason the results for CMB have been made available in the appendix B but the discussion below will be focused on the effects of CTS vs CTL diet at T12h post challenge. In total, 3483 proteins associated with the liver proteome were identified and quantified by the label-based quantitative proteomic approach. Among these, 1373 proteins belonging to set criteria (2 unique peptides and 5% FDR) were identified from Proteome Discoverer: 108 proteins showed significantly differential abundances in CTS diet compared to CTL ($p < 0.05$) with 46 proteins associated to unique gene names (14 proteins upregulated and 32 downregulated). In the muscle proteome, 726 proteins were identified and quantified with 671 of them belonging to set criteria (2 unique peptides and 5% FDR). In total, 122 showed a significantly differential abundance between CTS vs CTL diets with 57 proteins related to unique genes (14 upregulated and 43 downregulated by CTS) (Table 4.3).

	Tot. proteins identified	Proteins (2 unique peptides and 5% FDR)	Proteins ($p < 0.05$) associated to unique genes	Proteins increased by CTS	Proteins decreased by CTS
Liver	3843	1373	46	14	32
Muscle	726	671	57	14	43

Table 4.3 Effects of CTS diet on the liver and muscle proteome at T12h post LPS challenge

The table indicates the total number of proteins identified in liver and muscle samples and the subsequent filtering steps. Respectively from the left column to the right: proteins with a minimum number of 2 unique peptides and 5% FDR, total number of proteins associated to unique genes which showed significant difference ($p < 0.05$) when comparing CTS vs CTL diet and the proteins significantly increased and decreased by CTS.

4.3.2.1 Effect of CTS diet on the liver proteome (CTS vs CTL diet at T12h)

In liver samples, the 46 proteins related to unique genes, differentially abundant between CTS and CTL diet at T12h post challenge were investigated in detail. A description of the first 30 significant proteins, along with their associated unique gene names and their description is provided in the Table 4.4, the full list is provided in the supplementary information in appendix B.

Volcano plots identified 4 unique proteins to be downregulated in the CTS diet by both log p and log fc (Figure 4.8): two of these proteins belonged to the fibrinogen family, peptidyl-prolyl cis-trans isomerase and alpha-2-macroglobulin (left green dots Figure 4.8); 4 unique proteins were also found to be upregulated: phosphoglucomutase-1, L-lactate dehydrogenase A (LDHA), NADH dehydrogenase and phosphoglucomutase 1 (right green dots in Figure 4.8). Heatmaps, showed the distribution of significant proteins and displayed good consistency among samples of both CTL and CTS diets (Figure 4.9).

Accession ID	Description	Gene name	Unique peptides	Median CTL	Median CTS	Fc	Log fc	p
118082784	ATP-dependent RNA helicase	DDX17	4	1.046	0.952	0.910	-0.136	0.002
971434955	alpha-2-macroglobulin	A2ML4	7	1.083	0.924	0.853	-0.229	0.002
971408766	phosphoglucomutase	PGM1	6	0.836	1.058	1.266	0.340	0.003
63509	Heat shock protein 90	HSP90B1	8	1.015	0.976	0.962	-0.057	0.004
134800	Spectrin	SPTAN1	12	1.044	0.95	0.910	-0.136	0.004
211827	heat shock protein 70	HSPA5	9	1.053	0.993	0.943	-0.085	0.005
53135191	hypothetical protein	LRPPRC	3	1.029	0.977	0.949	-0.075	0.005
33331366	phosphoglucomutase 1	PGM1	8	0.916	1.078	1.177	0.235	0.005
50729534	homogentisate 1,2-dioxygenase	HGD	4	1.0465	0.95	0.908	-0.140	0.006
63516	heat shock protein 90	HSP90AA1	13	1.015	0.951	0.937	-0.094	0.007
126046	L-lactate dehydrogenase A	LDHA	2	0.916	1.134	1.238	0.308	0.007
1334744	spectrin	SPTAN1	11	1.045	0.95	0.909	-0.138	0.008
113610	fructose-bisphosphate aldolase B	ALDOB	13	0.984	1.108	1.126	0.171	0.009
971425748	NADPH cytochrome P450 reductase	POR	6	1.048	0.994	0.948	-0.076	0.009
53127632	heat shock protein 70	HSPA9	7	1.012	0.973	0.961	-0.057	0.010
53132642	hypothetical protein	PDIA4	6	1.042	0.94	0.902	-0.149	0.012
694016481	40S ribosomal protein S28	RPS28	2	0.996	0.917	0.921	-0.119	0.013
1390057732	40S ribosomal protein S19	RPS19	2	1.029	0.98	0.952	-0.070	0.014
971185	fibrinogen	FN1	3	1.124	0.956	0.851	-0.234	0.015
8569621	Fibrinogen	FGA	3	1.124	0.956	0.851	-0.234	0.015
1390063686	alpha-2-macroglobulin	A2M	3	0.991	0.877	0.885	-0.176	0.015
971438075	histidine	HINT2	2	1.049	0.981	0.935	-0.097	0.016
971425736	NADPH--cytochrome P450 reductase	POR	7	1.048	0.993	0.948	-0.078	0.020

304277331	NADPH-cytochrome P450 oxidoreductase	POR	4	1.048	0.994	0.948	-0.076	0.021
971450877	NADH dehydrogenase	NDUFB7	2	0.998	1.1785	1.181	0.240	0.022
118094989	coatomer	COPB2	3	1.086	0.982	0.904	-0.145	0.023
65322	heat shock protein 90	HSP90AB1	4	1.002	0.934	0.932	-0.101	0.025
971442707	retinol dehydrogenase	LOC107056277	3	0.962	1.062	1.104	0.143	0.026
44969651	calreticulin	LOC100859104	2	0.994	0.917	0.923	-0.116	0.029
3641556	fibrinogen	FGG	2	1.09	0.903	0.828	-0.272	0.029

Table 4.4 Differentially expressed proteins ($p < 0.05$) in CTS vs CTL diet at T12h post LPS challenge in liver samples

List of the first 30 significant protein with differences in abundance between groups associated to unique genes with the median in CTL and CTS diets (relative to internal standards), fc, Log fc and p . Proteins are listed, in order starting from the lowest in p . Proteins listed in order of increasing p .

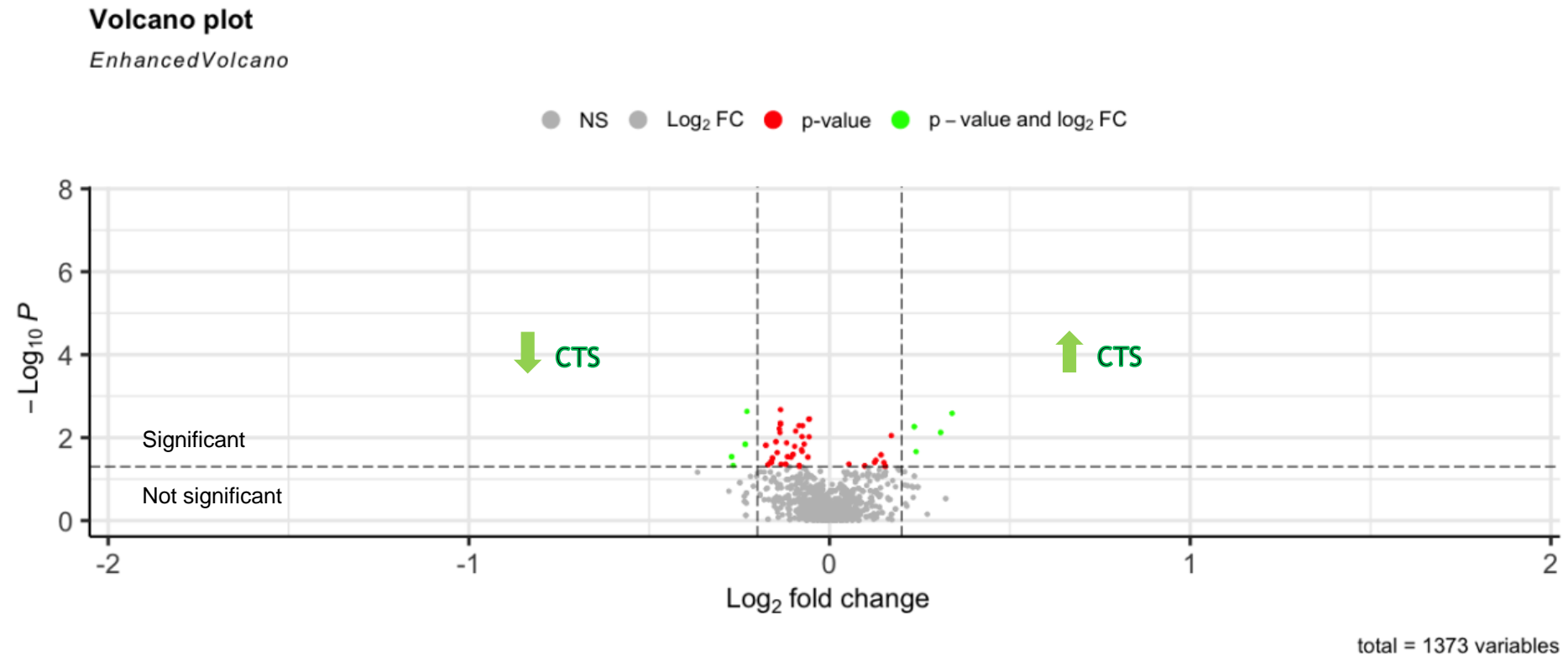

Figure 4.8 Volcano plots comparing liver proteome in CTS vs CTL diet at T12h post LPS challenge

Plot of protein data CTS vs CTL depicting the log fc vs. log p . The green dots included between the log $p > 1.2$ ($p < 0.05$) and log fc < -0.2 and > 0.2 represents respectively the ones downregulated and upregulated by both log p and log fc, in CTS diet (proteins where CTS diet has a higher impact). Red dots represent significant proteins ($p < 0.05$) regulated just by the log p ($p < 0.05$). Grey dots indicate proteins which are not significant by both log p and log fc (NS) or by log p .

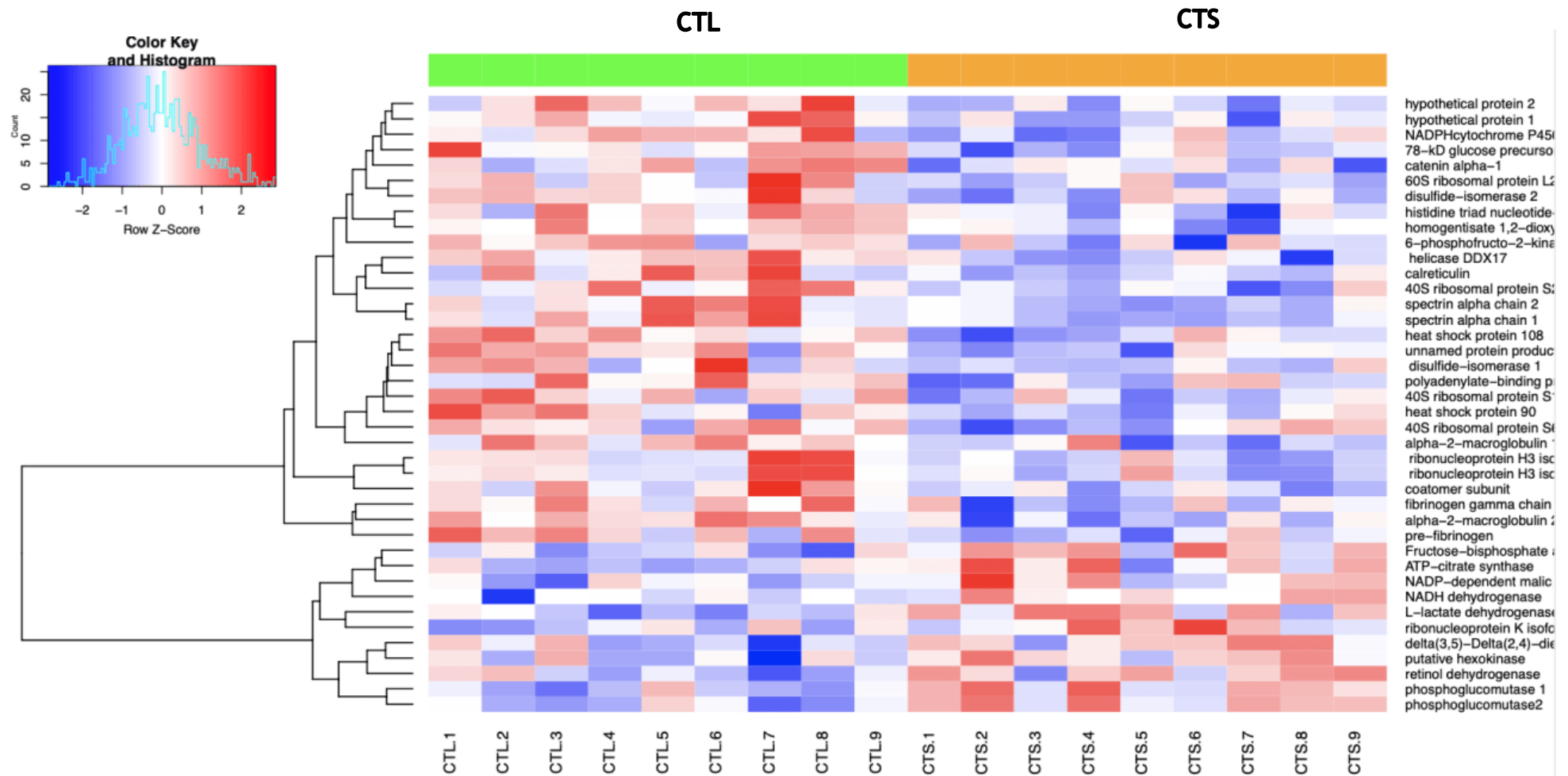

Figure 4.9 Heat maps of liver proteome in samples of CTS vs CTL diet at T12h post LPS challenge

Heat map presenting significant differentially expressed proteins ($p < 0.05$) in CTL (green line) vs CTS (orange line) diet. The blue colour indicates the proteins significantly downregulated by one of the diets while the red colour indicates the ones upregulated. On the left, the Phylogenetic Clustering of proteins indicates their phylogeny. The name of each significant protein is indicated on the right.

Ontology investigation using the GO Slim analysis in PANTHER GO resource liver proteins with significant differences in abundances within CTS and CTL group were involved in the following molecular functions: binding (14 genes), catalytic (11 genes) and structural activity (3 genes) (Figure 4.10). The main proteins associated with binding activity belonged to the family of heat shock proteins: Hsps90 (Hsp90AB1, Hsp90AA1, Hsp90B1) and Hsp70 (HspA9, HspA5) were found to be lower in abundance in CTS diet. The main proteins involved in catalytic activity were LDHA, malic enzyme (ME1), which are involved respectively in oxidoreductase reactions of lactate fermentation and Citrate cycle, and fructose-bisphosphate aldolase B (ALDOB) which participates in the glycolysis lyase reaction by converting Fructose-1,6BP to Glyceraldehyde 3P and Dehydroxiacetone-P. These proteins were found higher in abundances in CTS diet and are intermediates of energy metabolic pathways (e.g glycolysis, pyruvate and pentose phosphate).

In biological processes, proteins were found to be associated to cellular processes (19 genes), metabolic processes (11 genes), biological regulation (9 genes), response to stimulus (6 genes), localization (1 gene) and signalling (1 gene) (Figure 4.10). Among the proteins involved in cellular processes, Hsp90 and Hsp70 were found involved in both protein folding and cellular response.

In this investigation, the key proteins modulated by CTS diet at T12h post injection are represented by heat shock proteins (Hsp90, Hsp70) and metabolic enzymes (LDHA, ME1, ALDOB).

CTS vs CTL

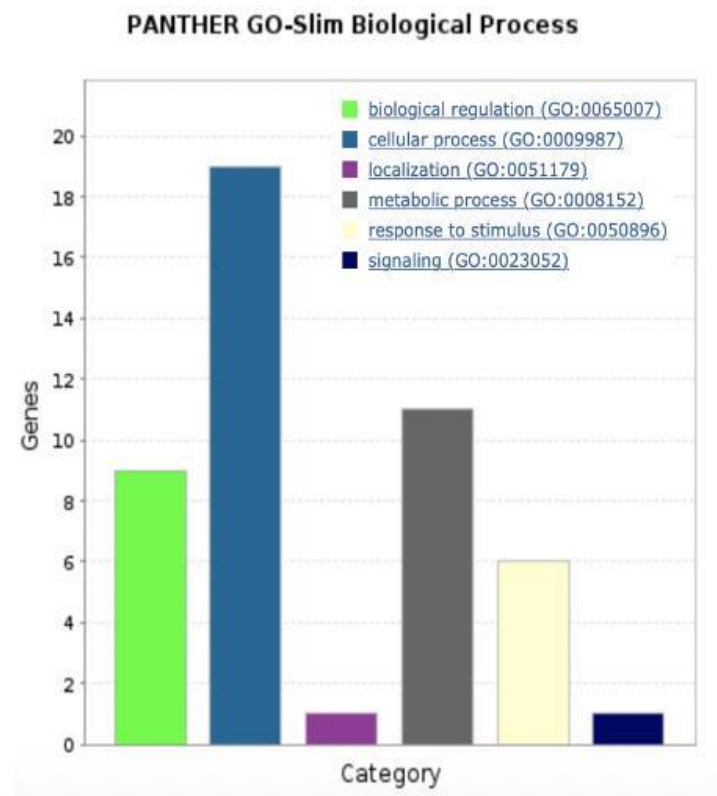
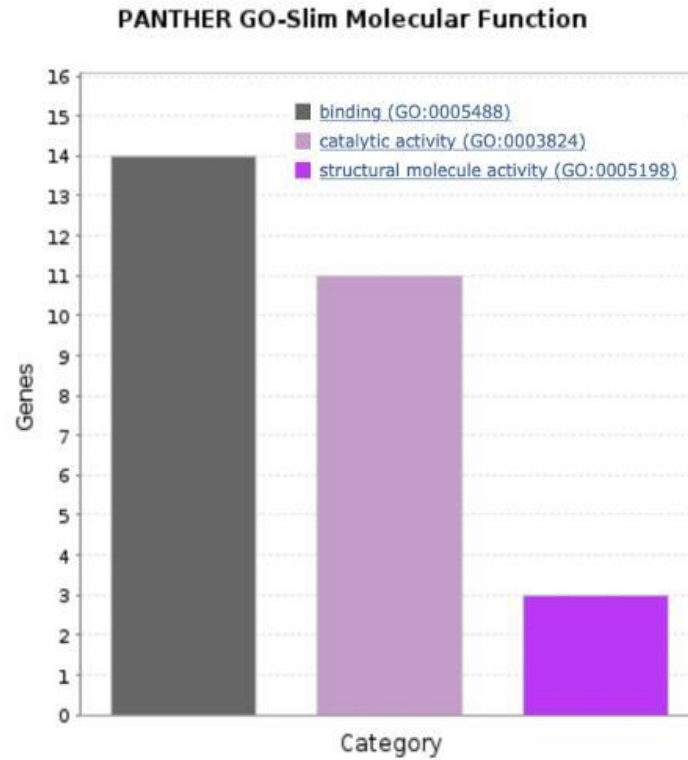

Figure 4.10 GO slim analysis of differentially expressed liver proteins in CTS vs CTL diet at T12 post LPS challenge

The x-axis unit of percentage (%) is the number of genes in GO term. Molecular functions and biological process of CTS vs CTL are shown.

4.3.2.2 Effect of CTS diet on the muscle proteome (CTS vs CTL diet at T12h)

In muscle samples, the 57 differentially abundant proteins associated to unique gene names, between CTS and CTL diet at T12h post challenge, were investigated in detail. The description of the first 30 proteins significantly different, their unique gene names with the relative values of fc , $\log fc$ and p are indicated in the table below (Table 4.5). The list of all proteins is shown in the supplementary information (appendix B).

The distribution among the differentially expressed proteins, comparing the $\log fc$ ($-0.2 < \log fc < 0.2$) vs. $\log p$, was explored through the volcano plots (Figure 4.11): 28 proteins were found to be downregulated by both ($\log fc$ and $\log p$) in CTS diet (left green dots in Figure 4.11) with 11 of them belonging to unique gene names (myosin (MHC), six isoforms of tubulin, tropomyosin beta chain (TPM), phosphorylase b kinase (PHKB), Peroxiredoxin-1 (PRDX1), glycogen phosphorylase (PYGL)). On the other hand, 9 proteins were identified to be significantly upregulated by CTS diet with 5 of them belonging to unique gene names (glyceraldehyde-3-phosphate dehydrogenase (GAPDH), fructose-1,6-bisphosphatase (FBP2), aldolase A (ALDOA), protein ADP-ribosylarginine hydrolase (ADPRS) and an unnamed protein) (right green dots in Figure 4.11).

Heat maps indicated the significant proteins ($p < 0.05$) in CTS vs CTL groups. In CTL diet, protein's abundance is similar among samples while there is a higher variability in CTS diet (Figure 4.12).

Accession ID	Description	Gene name	Unique peptides	Median CTL	Median CTS	fc	Log fc	<i>p</i>
63433	H2A Histone Family Member J	H2AFJ	2	1.067	0.878	0.823	-0.281	0.000
63439	histone cluster 1 H2A family member 4.	HIST1H2A4	2	1.067	0.878	0.823	-0.281	0.000
63448	histone cluster 1 H2A family	LOC101750582	2	1.067	0.878	0.823	-0.281	0.000
63466	H2A Histone Family Member V	H2AFV	2	1.067	0.878	0.823	-0.281	0.000
971416845	histone H2A	LOC101751709	2	1.067	0.878	0.823	-0.281	0.000
45382147	tudor-interacting repair regulator protein	NUDT16L1	4	1.155	0.902	0.781	-0.357	0.001
118097461	myozenin-3	MYOZ3	4	1.093	0.914	0.836	-0.258	0.001
9789730	Sarcoplasmic/endoplasmic reticulum calcium ATPase	ATP2A2	4	1.156	0.852	0.737	-0.440	0.002
238273	myosin heavy chain	MHC	2	1.091	0.862	0.790	-0.340	0.005
773669241	myomesin-1	MYOM1	15	1.159	0.943	0.814	-0.298	0.006
60098993	hypothetical protein	HK1	5	1.027	0.887	0.864	-0.211	0.008
294662216	myosin heavy chain	MHC	4	1.119	0.910	0.813	-0.298	0.009
62738642	Annexin A5	ANXA5	2	1.081	0.884	0.818	-0.290	0.009
971414380	phosphorylase b kinase	PHKB	9	1.077	0.889	0.825	-0.277	0.010
212834	beta-tubulin	TUBB1	3	1.155	0.922	0.798	-0.325	0.011
513180238	phosphorylase b kinase	PHKA1	3	1.094	0.904	0.826	-0.275	0.011
459714	tubulin	TUBB	7	1.155	0.949	0.822	-0.283	0.012
238272	myosin heavy chain	MHC	2	1.178	0.993	0.843	-0.246	0.017
212659	skeletal muscle C-protein	MYBPC2	22	1.099	0.834	0.759	-0.398	0.019
53136740	hypothetical protein	PFKP	3	1.063	0.926	0.871	-0.199	0.026
212868	vimentin	VIM	7	1.034	0.681	0.659	-0.603	0.029

1016080546	vimentin	VIM	7	1.034	0.686	0.663	-0.592	0.037
53127891	hypothetical protein	SLC25A3	2	1.006	0.568	0.565	-0.823	0.038
1777308	connectin/titin	TTN	2	1.353	0.791	0.585	-0.774	0.039
971380098	heterogeneous nuclear ribonucleoproteins A2/B1	HNRNPA2B1	2	1.066	0.927	0.870	-0.202	0.039
833608	collagen a2	COL1A2	2	0.935	0.600	0.642	-0.640	0.040
300630016	unnamed protein product	HK1	4	1.008	0.884	0.877	-0.189	0.041
211607	alpha-2 type I collagen	COL1A2	4	0.909	0.571	0.628	-0.671	0.042
45382029	annexin A6	ANXA6	5	1.085	0.892	0.822	-0.283	0.042
263505112	Peroxiredoxin-1	PRDX1	2	1.067	0.932	0.874	-0.194	0.045

Table 4.5 Differentially expressed proteins ($p < 0.05$) in CTS vs CTL diet at T12h post LPS challenge in muscle samples

List of first 30 significant proteins associated to unique genes with the relative median in CTS and CTL diets, fc, Log fc and p . Listed by increasing p

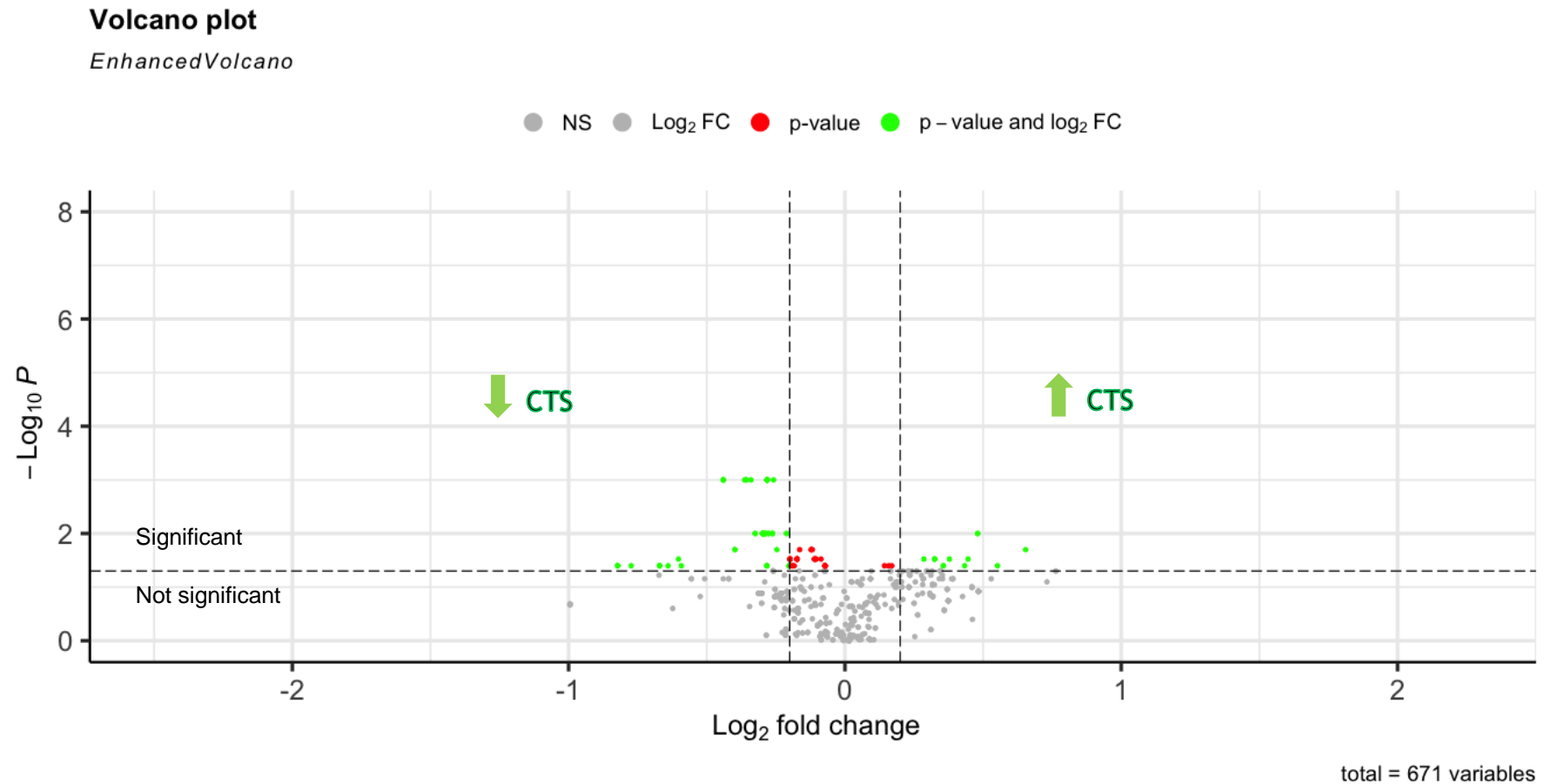

Figure 4.11 Volcano plots comparing muscle proteome in CTS vs CTL diet at T12h post LPS challenge

Green dots between $\log p > 1.2$ ($p < 0.05$) and $\log fc < -0.2$ and > 0.2 represent respectively the proteins downregulated and upregulated in CTS diet, by both $\log p$ and $\log fc$. Red dots indicate significant proteins ($p < 0.05$) regulated just by the $\log p$. Grey dots are referred to no significant proteins by both $\log p$ and $\log fc$ (NS) or by $\log p$ but not $\log fc$.

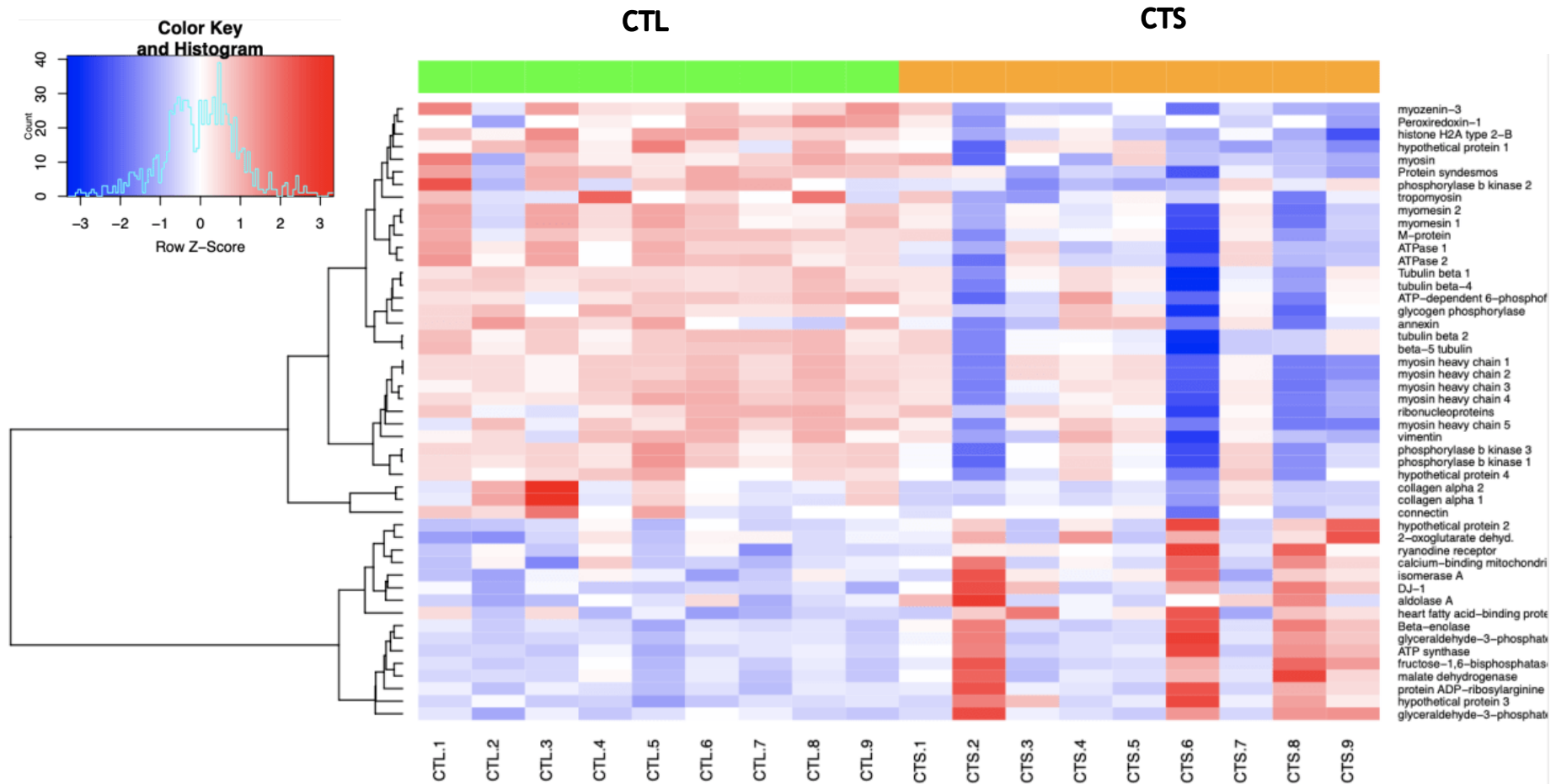

Figure 4.12 Heat maps of muscle proteome in samples of CTS vs CTL diet at T12h post LPS challenge

Heat map indicates the significant proteins ($p < 0.05$) associated to unique genes identified in CTS (orange line) vs CTL (green line) diet. The blue colour represents proteins which are significantly downregulated by one of the diet while the red colour is referred the ones upregulated. The phylogenetic clustering of proteins is shown on the left while the name of each significant protein is indicated on the right.

Molecular functions, biological processes, and pathways were studied in the PANTHER GO resource following the same method applied for liver proteomics.

In the study of molecular functions, significant differences were noted for proteins which were associated with catalytic activity (14 genes), binding activity (13 genes) while a minority were associated with structural (5 genes) and transporter (4 genes) activity (Figure 4.13). The proteins, involved in catalytic activity, which were more strongly modulated by CTS diet (higher in relative abundance compared to CTL), were FBP2, MDH1, GAPDH, beta-enolase (ENO3) and nucleic acid deglycase DJ-1 (PARK7). Regarding binding activity: TPM2, isoforms of tubulin beta chain (TUBB3 and TUBB4B), myosin (MHC) were identified to be significantly lower in abundance in the CTS diet. In terms of biological process most proteins were found to be involved in cellular process (26 genes) (Figure 4.13). This category includes intermediates of metabolic processes (15 genes) mainly involved in energy metabolism (e.g glycolysis, and the Citrate cycle) such as FABP2, MDH1 and GAPDH.

In this investigation, the key proteins modulated by CTS diet at T12h post injection are represented by metabolic enzymes (GAPDH, MDH1, ENO3) which show higher abundance in CTS diet and structural proteins (tubulin and myosin) which show lower abundance in CTS diet.

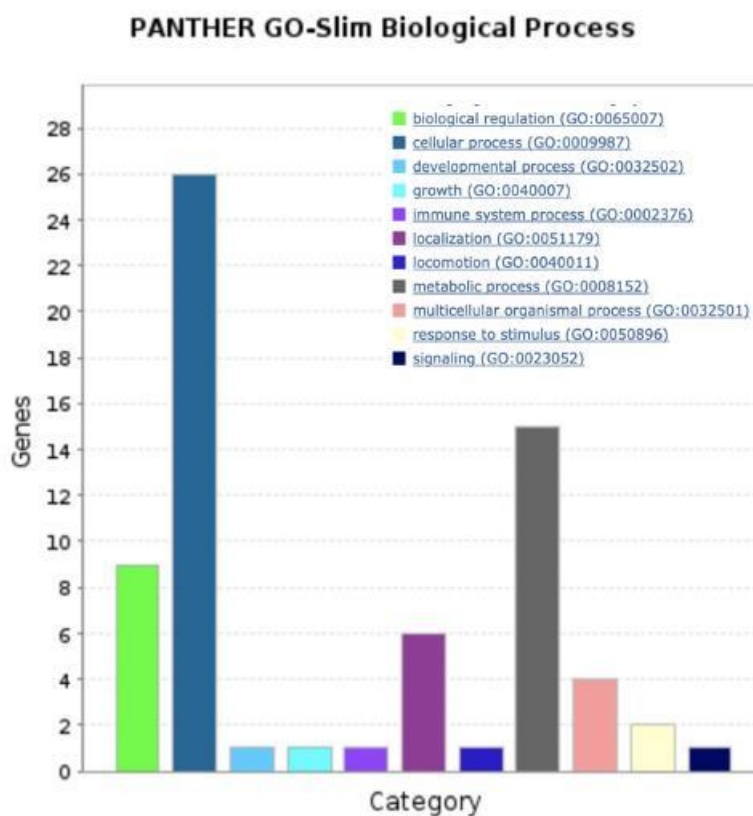
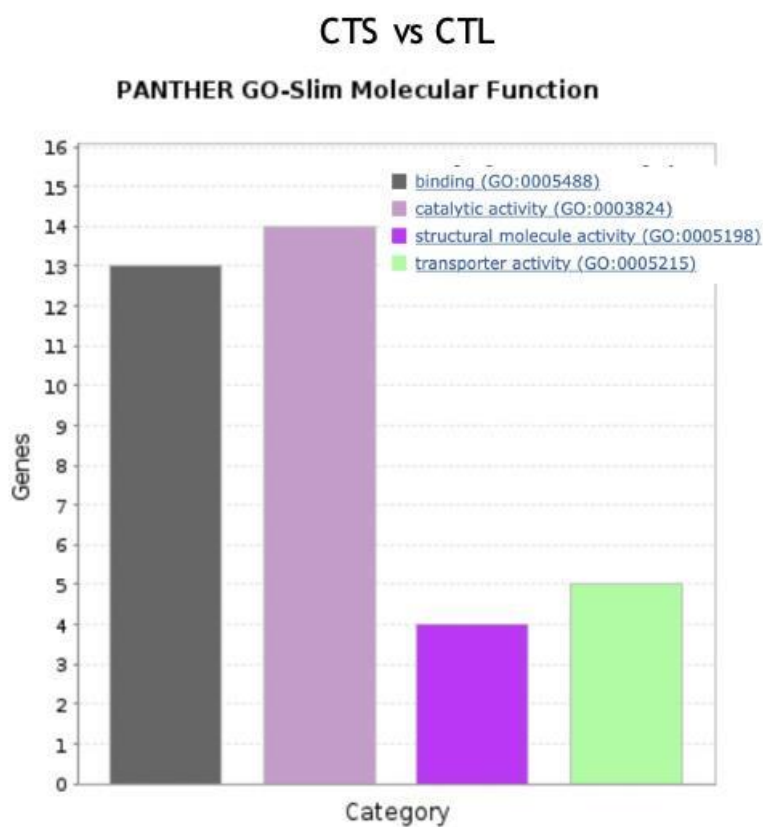

Figure 4.13 Gene ontology terms of differentially expressed proteins associated with the muscle proteome in CTS vs CTL diet at T12h post LPS challenge

The x-axis unit of percentage (%) is the number of genes in GO term. Molecular functions and biological processes of CTS vs CTL are represented.

4.3.3 Relevant findings in the liver and muscle proteome of broilers associated to LPS effect in CTL diet and CTS diet at 12h post challenge

The key findings of both proteomics investigations have been summarised in the Table 4.6 below.

	Key findings
LPS effect at 12h post challenge	
Liver	↑ heat shock proteins (Hsp90, Hsp70)
Muscle	↑ <u>kelch-like protein</u>
CTS effect at 12h post LPS challenge	
Liver	↓ heat shock proteins (Hsp90, Hsp70) ↑ metabolic enzymes (LDHA, ME1, ALDOB).
Muscle	↓ structural proteins (tubulin and myosin) ↑ metabolic enzymes (GAPDH, MDH1, ENO3)

Table 4.6 Summary of the key findings on the effects of LPS and CTS diet on liver and muscle proteome at T12h post LPS challenge

The table indicates the main proteins modulated by the effect of LPS and CTS diet at T12h post LPS challenge on the muscle and liver proteome.

4.3.4 Validation of liver proteins by Western Blot procedure

Based on proteomics results and availability of antiserum, LDHA and Hsp90 were elected as the preferable proteins to be validated through WB procedure. WB was performed using LDHA and Hsp90 antibodies on 4 gels aimed to compare both dietary treatments (CTL and CTS) and timepoints (T0 and T12). In each gel, the bands referring to LDHA or Hsp90 were obtained. The molecular weight of LDHA (manual of Abcam, cat no. 130923), corresponded to the band of 36 kDa, while the molecular weight of Hsp90 (manual of Rockland antibodies and assays, cat no. 600-401-929) was found correspondent to the band of 90 kDa (Figure 4.14). The abundance of each band per gel was quantified by Image J software. No significant differences were discovered by comparing CTL T0 vs CTL T12 (gel 1), CTL T12 vs CTS T12 (gel 2), CTS T0 vs CTS T12 (gel 3) and CTL T0 vs CTS T0 (gel 4) in terms of LDHA and Hsp90 abundances ($p > 0.05$). The abundance of LDHA was found to increase in CTS T12 relative to the CTL T12 group; even if it did not show significance, its trend reflected the proteomics results (Figure 4.15). In the same way, Hsp90 abundances among samples were investigated, and data confirmed that their abundances decreased in samples of CTS T12 when compared to CTL T12 (Figure 4.15).

LDHA

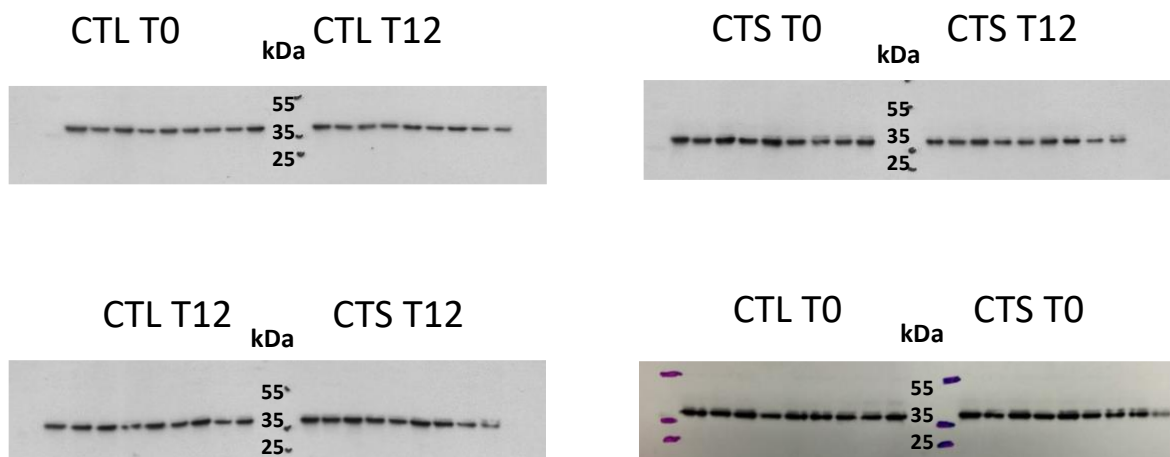

HSP90

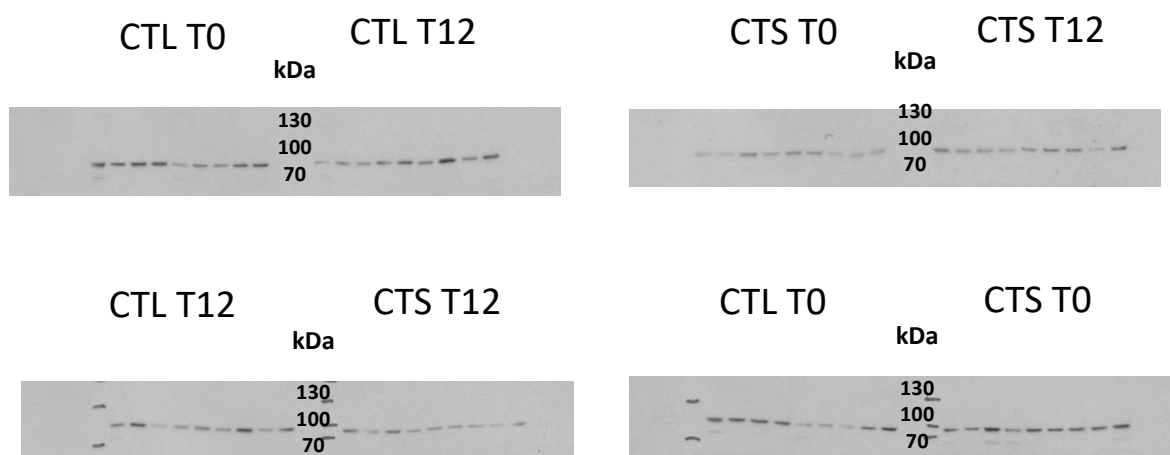

Figure 4.14 LDHA and Hsp90 gels of liver samples comparing CTL T0 vs CTL T12 (gel 1), CTL T12 vs CTS T12 (gel 2), CTS T0 vs CTS T12 (gel 3) and CTL T0 vs CTS T0 (gel 4)

Each band on the gels represents the abundance of LDHA and Hsp90 protein per each sample (N= 9 samples per each group). The molecular weight is indicated in kDa. The LDHA band corresponds to a molecular weight of 40 kDa while the abundance of Hsp90 is represented by the band of 90 kDa in all gels.

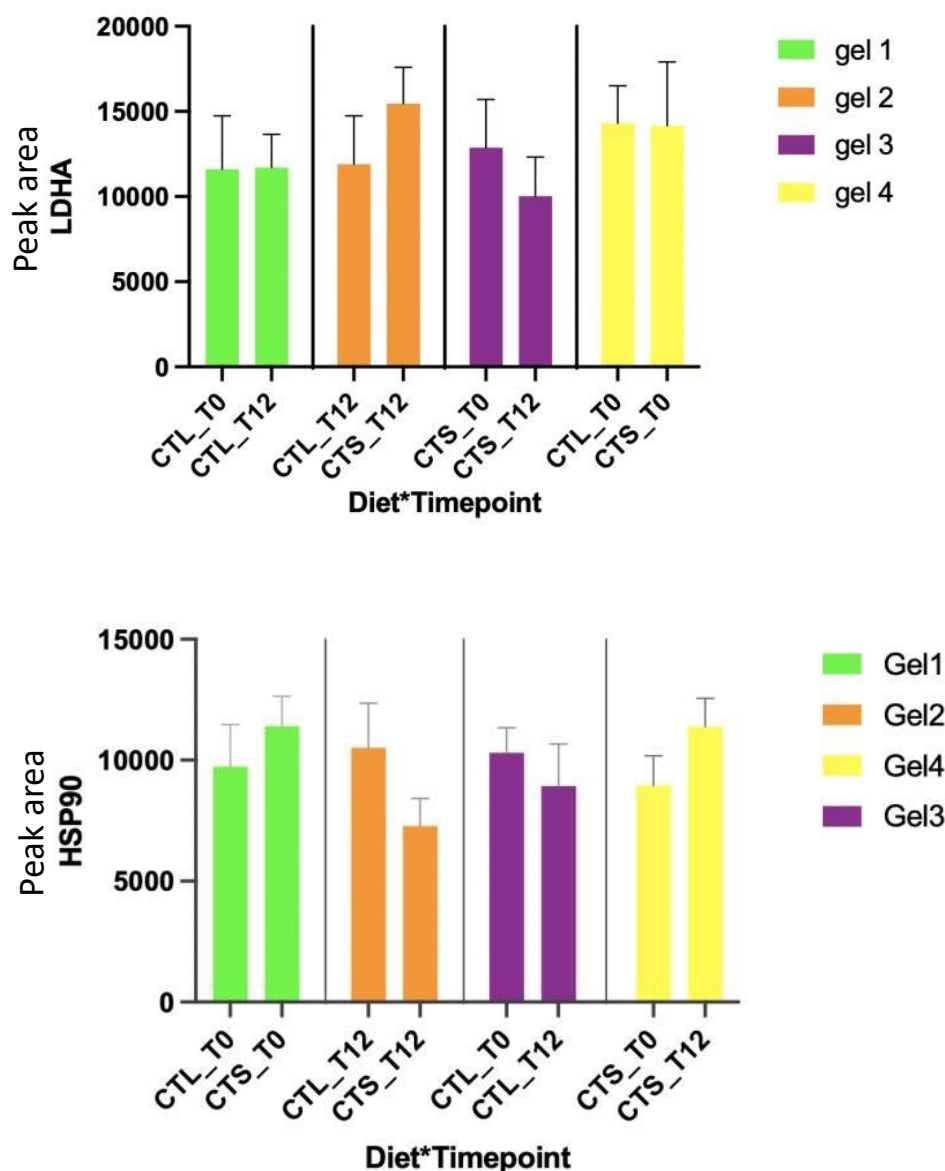

Figure 4.15 LDHA and Hsp90 abundances in liver samples comparing CTL T0 vs CTL T12 (gel 1), CTL T12 vs CTS T12 (gel 2), CTS T0 vs CTS T12 (gel 3) and CTL T0 vs CTS T0 (gel 4)

Peak area \pm SD of the mean of LDHA and HSP90 belonged to each dietary group at T0 pre challenge and T12 post challenge is represented. No significant differences are discovered based on LDHA and Hsp90 abundances in all gel's groups. A slight difference in LDHA abundance is highlighted in CTL T12 vs CTS T12 (gel 2). In gel 2 the abundance of Hsp90 is shown to decrease in CTS T12 when compared to CTL T12 but the difference was found to be not significant.

4.3.5 Validation of muscle proteins by Western Blot procedure

In muscle, GAPDH was considered the best candidate proteins to be validated thanks to the commercially available anti-GADPH already tested in broilers and its active role in the metabolism.

The validation of possible differences in GAPDH as found by proteomics was carried out using the same approach applied for liver samples, but in this case only CTL T12 vs CTS T12 samples were compared being performed in a single gel. In the Figure 4.16, samples of both groups, CTL_T12 and CTS_T12, are represented and the molecular weight of GAPDH corresponded to the band around 35/40 kDa (manual of Abcam, cat no. 125247). The abundance of both proteins was studied but no significant difference was found comparing the abundance of GAPDH in both groups (Figure 4.17).

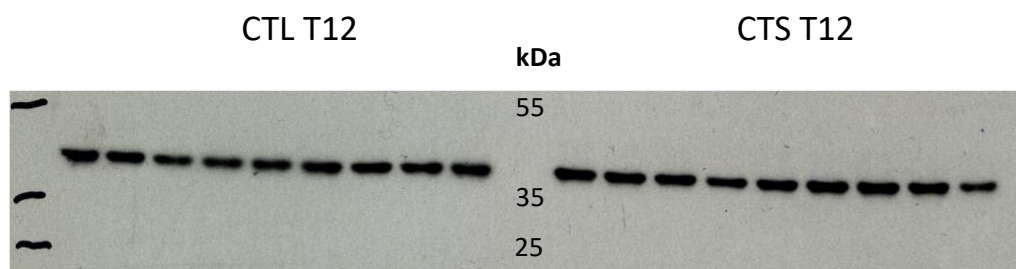

Figure 4.16 GAPDH gel of muscle samples comparing CTL T12 vs CTS T12

Each band indicates the abundance of GAPDH proteins per each sample (N= 9 per each group). The molecular weight is indicated in kDa. The GAPDH band corresponds to a molecular weight of 35/40 kDa.

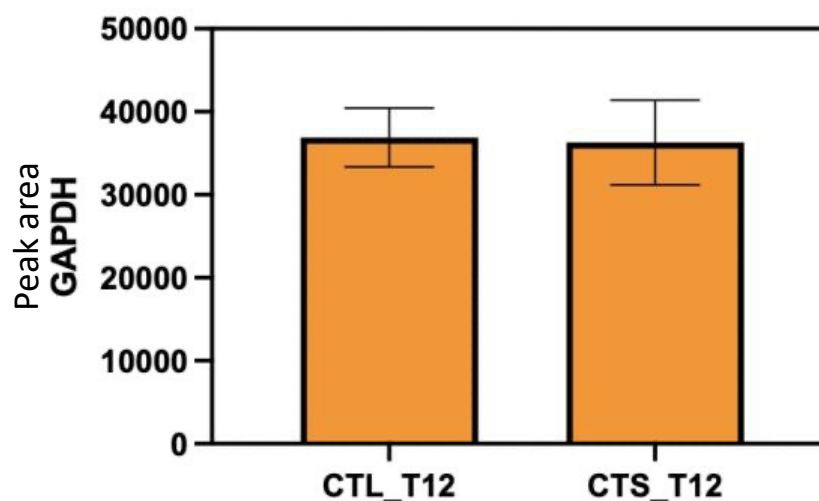

Figure 4.17 GAPDH abundances in muscle samples of CTL T12 vs CTS T12

Peak area \pm SD of the mean of GAPDH is represented. No significant differences are discovered based on GAPDH abundances between CTL_T12 vs CTS_T12.

4.4 Discussion

In this chapter I applied a proteomics to investigate the effects of LPS in liver and muscle obtained from trial 2. Because of the costs involved our approach was to limit sample size and choice, without compromising on our ability to address fundamental questions viz. how the liver and muscle proteome responds to LPS challenge in broiler chickens, and if dietary supplementation with CTS or CMB extract results in modulatory effects that could benefit bird health.

Two proteomic studies were carried out. In the first study the effect of LPS challenge on the liver and muscle proteome was investigated by comparing samples from broilers fed the CTL diet at T0h and T12h post LPS challenge. The second study compared tissues collected from the CTS or CMB diet at T12h post LPS challenge with those from the CTL diet collected at the same timepoint. Our data shows that LPS administration had a major impact on the liver proteome (study 1) and that the livers response to LPS was highly modulated in broilers receiving the CTS diet (study 2). The liver proteome of broilers receiving the CMB diet was also modulated post LPS challenge (study 2), but the effects were much more subtle and directly related to either immune functions or metabolism. The muscle proteome was not significantly influenced by LPS administration (study 1) but differences in the response were again noted in terms of dietary treatment (study 2). The most significant of these changes were again found in the CTS diet.

The key proteins identified in study 1 are now discussed in relation to their known functional properties and for study 2 how their abundance maybe influenced by the bioactive compounds present in our two novel plant extracts.

Effects of LPS challenge on the liver proteome

Proteins found to be modulated by LPS at T12h post challenge included a number of serum proteins, structural proteins and metabolic enzymes. The proteins that attracted our attention most were those that belonged to the Hsp families (Hsp90AA1, Hsp90B1, HspA5). These were all found to be significantly higher in the CTL diet at T12h post challenge compared to samples at T0h.

Hsps includes a number of families with different molecular weights (Hsp110, Hsp90, Hsp70, Hsp60 and Hsp47) and a small group of Hsps with a molecular weight in the range of 16 to 40 kDa (Heckathorn, Downs, and Coleman 1999) Hsps play different roles in

cellular activity such as protein folding, assembly of multiprotein complexes, transport and sorting of proteins into correct subcellular compartments, cell-cycle control and signalling, and protection of cells against stress/apoptosis and are also involved in signal transduction (Shan et al., 2020; Takayama et al., 2003). Hsp's also known as stress proteins are synthesised in response to environmental changes such as high temperature (heat stress) or exposure to oxidative stress, leading to damage and degradation of intracellular proteins (Slawinska et al., 2016).

Hsp90 was one of the main families modulated in the liver at T12h post LPS challenge. Hsp90 has been shown to play a role in a myriad of cellular processes and immune responses in both humans and animals (Hoter et al., 2018). In broilers, Hsp90 is normally expressed at low levels, but when birds are subjected to heat stress, higher levels have been detected in the heart, liver and kidney (Lei et al., 2009). Hsp90 expression has also been found to be naturally higher in modern commercial genetic lines compared to indigenous species presumably because of their more rapid metabolism and higher body temperature (Hassan et al., 2018). The increased detection of Hsp90 observed in our study of the liver proteome can therefore be attributed to pyrexia and the corresponding cytotoxicity (Slawinska et al., 2016) caused by the LPS challenge. While I was not able to confirm these results by WB, I was nevertheless able to confirm the presence of Hsp90 in our liver samples. Possible reasons may be associated to the significance ($p = 0.04$) of Hsp90 found from the proteomics investigation that was not strong enough to show a significant result in the WB. Another possibility is that the linearity and sensitivity of the WB can be affected by antibodies unverified (i.e. predict to react in the species of interest) (Gilda et al., 2015). In our experiment, antibodies were predicted to react in chickens, so an optimization of the protocol was required. It is also worth noting that the WB validation step could have been repeated by selecting one of the other Hsp proteins (e.g. Hsp70) that were modulated by the LPS challenge, but this was not possible due to time and funding constraints. Arguably the fc in the abundance of these proteins in the liver proteome post LPS was significant but also quite subtle.

The work of Horvatić et al. (2019) demonstrated that an LPS challenge administered in the form of a single subcutaneous injection causes oxidative stress in broilers, and that this results in inflammatory damage by increasing proinflammatory pathways (NF- κ B and Cox-2). These authors also confirmed that the APR in broilers is registered in the first T12h following LPS administration. This was our justification for selecting T0h and T12h post

challenge as the key timepoints for studying both the liver and muscle response to LPS challenge.

Interestingly, none of the established and novel APPs (SAA, AGP, FABP and Hpx) studied in chapter 3 featured in the list of liver associated proteins that were modulated by LPS. This was surprising as the majority of APPs are produced in the liver (O'Reilly and Eckersall 2014). SAA was detected by the instrument but as it showed less than two unique peptides, this data would have been filtered out. AGP, FABP and Hpx were not detected. The most plausible explanation for these results is that during the APR these APPs are synthesised so rapidly and then immediately exported into the serum that no increase in their abundance can be detected. Two other APPs however were detected: alpha 2 macroglobulin and fibrinogen (Jain et al., 2011). Both of these APPs have been confirmed by other studies in humans and livestock to increase in their abundance during an inflammatory response as products of APR (Vandooren and Itoh, 2021; Jacobsen, 2007; Tothova et al., 2014; Salini et al., 2011). Fibrinogen is described as a minor APP in chickens and the difference here it is mainly attributed to one sample (Figure 4.6). To the best of our knowledge this is the first time alpha 2 macroglobulin has been described as an APP in chickens.

Effects of dietary supplementation on the response of the liver proteome post LPS

Study 2 compared CTL liver samples collected at T12h post LPS challenge with liver samples collected from birds fed CTS (or CMB) at the same timepoint. 45 unique proteins were modulated by CTS diet; among these the ones which were identified as being particularly interesting (because of their impact on the immune system and/or metabolism) included a number of Hsp family proteins (lower in abundance in CTS diet compared to CTL at T12h post challenge) and a number of metabolic enzymes including LDHA, ME1, ALDOB (higher in abundance in CTS diet compared to the CTL diet at T12h post challenge).

Lower abundances of Hsp70 and Hsp90 were detected in the liver of broilers fed the CTS diet at T12h post LPS challenge. This is particularly interesting as it suggests that one or more of the bioactive compounds of CTS extract could be responsible for downregulating these important families of protein. As previously suggested, increased levels of Hsp90 occur in the liver response to the pyrexia and corresponding cytotoxicity resulting from the LPS challenge (Slawinska et al., 2016). The most likely candidates in the CTS extract that could be responsible for modulating the Hsps are the flavonoids which have previously been shown to protect broilers from oxidative stress during LPS challenge (Kamboh et al., 2016).

Flavonoids are known to inhibit the synthesis of Hsps including Hsp90, Hsp70, Hsp47 and Hsp28 (Hosokawa et al., 1990). Genistein and Quercetin for example have been shown to inhibit tyrosine protein kinases which allow the formation of the Hsp90/Cdc37 complex that is responsible for coordinating /regulating many facets of the stress response (Akiyama et al., 1987; Siddiqui et al., 2021). Pectin, could also be responsible for the lower Hsp response in the CTS diet; pectin can bind and inhibit, toll-like receptor 2 (TLR2), a major target for LPS, and the proinflammatory TLR2–TLR1 pathway (Sahasrabudhe et al., 2018) (Aliprantis, 2000). Blocking the proinflammatory pathway in this way, will decrease Hsp production (Daneri-Becerra and Galigniana, 2016). However, the mechanism of action of pectin is still unclear and requires further investigations.

An alternative hypothesis is that the lower expression of Hsp90 in the liver could also be a signal of poorer metabolism (Aliprantis, 2000). Arguably however the CTS diet also appears to enhance energy metabolism by upregulating a number of liver associated metabolic enzymes. LDHA, for example regulates the processing of pyruvate fermentation to lactate (<https://www.uniprot.org/uniprot/P00340>), ME1 is involved in the oxidoreductase reaction of malate to pyruvate (<https://www.uniprot.org/uniprot/Q92060>), and ALDOB, contributes to the lyase reaction of glycolysis by converting Fructose-1,6BP to Glyceraldehyde 3P and Dehydroacetone-P (<https://www.uniprot.org/uniprot/P07341>). Although we were unable to confirm the result for our target proteins (Hsp90 and LDHA) by WB, LDHA is considered a key protein for further study on the role of CTS diet in promoting metabolism. The available literature confirms many plant extracts boost the metabolism (Pirgozliev, 2018) which could also explain the higher food intake, lower body weight and higher FCR observed in trial 1 (chapter 2) for the CTS diet. The inconclusive WB result may be associated to the loss of linearity and sensitivity of the method caused by the unverified antibodies (i.e. predict to react in the species of interest) (Gilda et al., 2015).

Effects of LPS on the muscle proteome

No major significant differences were found in the muscle proteome post (12h) LPS challenge. This may have been due to the short duration of the applied stressor which in this case was a single dose of LPS. According to the literature a common manifestation of a variety of disease processes is the loss of muscle mass as broilers can suffer from anorexia post LPS challenge. However, to contrast this stress condition, muscle proteins are catabolized to AA substrates to supply energy via liver gluconeogenesis (Gordon et al., 2013), although the mechanism of action is not clear. Ma et al. (2021) observed elevated

atrophy of breast muscle mass in broilers that had been subjected to prolonged heat stress; this study confirmed that the activation of muscle breakdown occurs in broilers to provide AA substrates to liver gluconeogenesis to supply energy under prolonged periods of stress. This indicates that a different timescale (e.g. considering later post challenge time points) is a reasonable explanation for not observing a massive proteome muscle change.

However, it's important to note that in our study I did see an increase of kelch-like protein T12h post LPS challenge. This protein has been found to be associated with prolonged heat stress in broilers (Hu et al., 2020). During heat stress, the content of superoxide free radicals and hydrogen peroxide significantly increase and induce oxidative stress through nuclear factor erythroid 2-related 2/Kelch-like ECH-associated protein 1 (Nrf2-Keap1) pathway (Zhang et al., 2018) (Song and King, 2015). Our results suggest that LPS initiates oxidative damage in broiler muscle through the activation of the Nrf2-Keap1 pathway. However, further investigation is required to confirm this hypothesis as just kelch-like protein was found. Based on these considerations, I could have observed a different result in muscle if I had used different time points post challenge or administered repeat injections of LPS, changed the mode of delivery or indeed used a different type of endotoxin.

Effects of dietary supplementation on the muscle proteome post LPS challenge

57 unique proteins were modulated in the muscle of broilers receiving the CTS diet at T12h post LPS challenge. Among these, the abundance of a number of metabolic enzymes (MDH1, ENO3, GAPDH) were found to be higher in CTS diet compared to CTL diet. Two structural proteins (tubulin and myosin) in contrast were lower in abundance. Unfortunately, I was not able to validate these results using GAPDH as our target protein by WB. Nevertheless, by exploring the literature possible interactions between the bioactive compounds in the CTS diet and each of these proteins was explored.

GAPDH and ENO3 are glycolysis enzymes which play an important role in energy generation in muscle cells. GAPDH is widely expressed in most cell types and its levels increase during the development of fast twitch muscle fibres in chickens (Stone et al., 1985). In rats, the study of Lowe et al. (2000) suggests that myofiber type in skeletal muscle influences GAPDH expression. Increased levels of GAPDH have also been registered in muscle during heat stress (Cedraz et al., 2017), the possible explanation is that the release of endotoxins causes a decline in pH and consequently a change in the activity of this enzyme

because glycolysis becomes the main pathway aimed to generate energy (Picard et al., 2010). The study of Kamboh et al. (2013) indicates that muscle hypermetabolism in livestock animals is typically caused by antemortem stress factors, particularly heat stress. No evidence was found to support the hypothesis that bioactive compounds found in CTS extracts can modulate GAPDH. Therefore, a possible explanation for this result is that the increase GAPDH is an indirect effect that relates more to the overall response to stress induced by LPS challenge in the CTS group.

The proteomics results also suggested that the abundance of myosin and tubulin was significantly lower in the muscle samples associated with the CTS diet, but these results could not be validated by WB. Myosin is a structural protein which binds to actin and is able to convert chemical energy in the form of ATP to mechanical energy resulting in muscle contraction (Nunnally et al., 1985). Calcium ions are the main signal, that can induce activation of actin-myosin interactions (Szent-Györgyi, 1975). Given the abundance of myosin ATPase in skeletal muscle, ATP hydrolysis by myofibrillar component is demonstrated to drive post-mortem changes to meat quality (Ferguson and Gerrard, 2014). Tubulin is the major constituent of microtubules and allows multiple important cellular functions such as structural support and pathways for transport (Binarová and Tuszynski, 2019). No evidence could be found that directly links the bioactive components found in the CTS diet to myosin and Tubulin. The observed lower abundances of these proteins are therefore interpreted as being consistent with the hypothesis that under stress conditions muscle atrophies and muscle proteins are catabolized to AA substrates to supply energy via liver gluconeogenesis (Gordon et al., 2013).

Conclusions

CTS diet revealed promising results in reducing the abundance of stress proteins (Hsp) and accelerating the metabolism of the liver in response to the activation of the immune system by LPS. This was mainly evidenced by the modulation of different Hsps and metabolic enzymes in liver as a result of the proteomics investigation. A possible interaction between bioactive compounds found in the CTS diet (e.g pectin, flavonoids) and Hsps, and some of the metabolic enzymes was also established. However, Western Blot results for 3 selected proteins (HSP90, LDHA and GAPDH) was inconclusive so further investigations are required to validate these findings. A tenuous link was also made between a number of

metabolic enzymes and structural proteins associated with muscle and the response associated with the CTS diet to LPS challenge which is worth further investigation.

In the next chapter a metabolomics approach is used to investigate the LPS response of broilers under each dietary regime in plasma collected from the same birds over a period of 48h post LPS challenge.

Chapter 5 Metabolomics on plasma samples: effects of novel plant extracts pre and post LPS challenge

5.1 Introduction

Metabolomics is an emerging field that studies the complete set of metabolites found in a biological sample (Agin et al., 2016). Metabolites referred to multiple small molecules such as amino acids, fatty acids, carbohydrates, or other products of cellular metabolic functions (Johnson et al., 2016). Metabolomics is used as a complementary approach to genomics, transcriptomics, and proteomics; the first manuscript on metabolomics was published in 1998 but the main development of this technique was reported to have occurred from 2010 (Pinu et al., 2019) so it can be considered as a new field of investigation. Metabolite levels and their ratios reflect metabolic function and animal health so when levels are out of normal range, it can be synonymous of disease or infection (Hasin et al., 2017). When a pathologic condition occurs, the levels of metabolites in the circulation reflect the host's condition. The main aim of metabolomics is to identify potential small molecule biomarkers that are correlate to diseases, environmental variation, specific dietary administration and to interrogate the overall metabolic network (Rinschen et al., 2019).

Mass Spectrometry (MS) is the preferred method for metabolite identification (Gowda and Djukovic, 2014) (see chapter 1). MS-based studies provide a highly sensitive means of compiling a metabolic profile. Metabolomics can be divided into targeted and non-targeted (Ribbenstedt et al., 2018). Targeted metabolomics is aimed to study and analyse specific known metabolites of interest (Roberts et al., 2012) while untargeted metabolomics analyse all detectable metabolites in a sample without a specific target (Schrimpe-Rutledge et al., 2016). As a discovery approach, untargeted analysis, can led to the discovery of novel biomarkers (Carneiro et al., 2019).

Metabolites can be detected in both plasma and tissues (see 1.9 Metabolomics -chapter 1). Plasma samples have already been used by researchers to study the metabolome of broilers post hatch (Van Every and Schmidt, 2021), on different dietary regimens (Wu et al., 2021) and at sexual maturity (Afrouziyeh et al., 2022). Plasma metabolites are an indicator of broilers health, but a wide range of factors can alter specific metabolites or the overall metabolome of broilers. LPS and dietary treatments can impact the metabolome profile of broilers during physiological or challenge conditions. The study of Barnes et al. (2002) and Asai et al. (2008) found a decrease in plasma amino acids in chickens post LPS challenge. Williams and O'Neill (2018) found that LPS can induce a significant decrease in the expression of genes involved in mitochondrial energy metabolism.

No information is available in the literature on the effects of citrus (CTS) and cucumber (CMB) diets on the broilers metabolome but both plant extracts could be potential modulators of metabolites due to active molecules such as pectin, vitamins, carotenoids and flavonoids included in the extracts (Vouldoukis et al., 2004; Farag et al., 2019; Fotakis et al., 2017) as discussed in chapter 1.

Metabolomics investigation generates big data, so a possible approach includes a first screening and overview of data by pooling samples based on a specific variable of interest (e.g age, sex, time points, pens etc.). Then, based on data generation, increase the number of individual samples for a study based on individual samples. This type of approach was used for our analysis: plasma samples from trial 2 (see chapter 3) were used to run two Untargeted metabolomics investigations in plasma with the main aim to explore the effects of LPS and experimental dietary treatments (CTS and CMB diets) on the broiler's metabolome. A functional study, based on plasma results, was then carried out. This was designed to evaluate the role of CTS diet in modulating the stress response of broilers before LPS challenge.

5.2 Aims and Objective of the study

The main aim of this study was to characterise the response of the plasma metabolome of broiler chickens to an LPS challenge and to test the hypothesis that dietary supplementation with CTS or CMB can modulate the plasma metabolome at T0h pre challenge and T12,24 and 48h post LPS challenge. The pooled sample and individual sample studies gave very comparable results and while the methods for both approaches are given in this chapter, the detailed results for the pooled samples are in the appendix C and the focus here is on the results of the study of individual samples.

The knowledge generated from this investigation will be used to identify novel biomarkers of broilers health and bioactive compounds in citrus and cucumber extracts which could interact with metabolites for reducing the stress or inflammatory response of broilers.

5.3 Materials and methods

5.3.1 Metabolomics: Summary workflow

Two untargeted metabolomics studies (LC-MS based), 1 pooled and 1 individual sample study, were performed to look at the effects of LPS challenge and diets on the metabolome of broilers at T0h pre challenge and T12, T24 and T48h post challenge. The pooled plasma study was performed at Glasgow Polyomics, University of Glasgow, with the grant support of British poultry science, UK. The following individual sample study took place at the facilities of the faculty of Faculty of Veterinary Medicine, Zagreb, Croatia. The workflow used for the two untargeted metabolomics studies was as follow: samples were extracted using chloroform/methanol/water (1:3:1) in the volume of 30/90/30 ml and separated by liquid chromatography (LC) before the MS identification. Data obtained from MS were investigated using Polyomics integrated Metabolomics Pipeline (PiMP), which identifies metabolites, and MetaboAnalyst which allows statistical analysis. The last stage of analysis includes the biological interpretation of the results and discussion. The Figure 5.1 below summaries the pipeline used for metabolomics investigation.

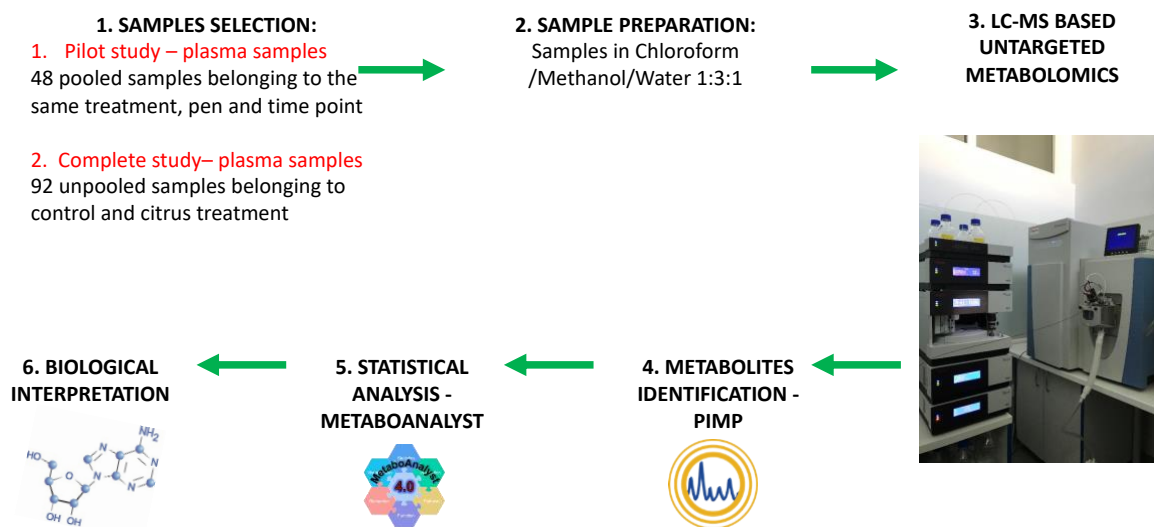

Figure 5.1 Workflow of LC-MS based Untargeted Metabolomics

Sample processing includes proteins extraction by chloroform, methanol, water (1:3:1), LC-MS/MS analysis, metabolites identification in PiMP, statistical analysis in MetaboAnalyst and biological interpretation.

5.3.2 Sample selection and preparation

Pooled study on plasma: plasma samples (N=144) from trial 2 (see 3.2.1 Trial 2 Experimental design - chapter 3), collected from broilers (15d old) belonging to all dietary groups (CTL, CTS and CMB) at T0h pre challenge and T12,24 and 48h post LPS challenge were pooled together based on the same diet as shown below in the Figure 5.2.

Figure 5.2 Pooling of samples for Untargeted metabolomics analysis in broilers fed with cucumber diet

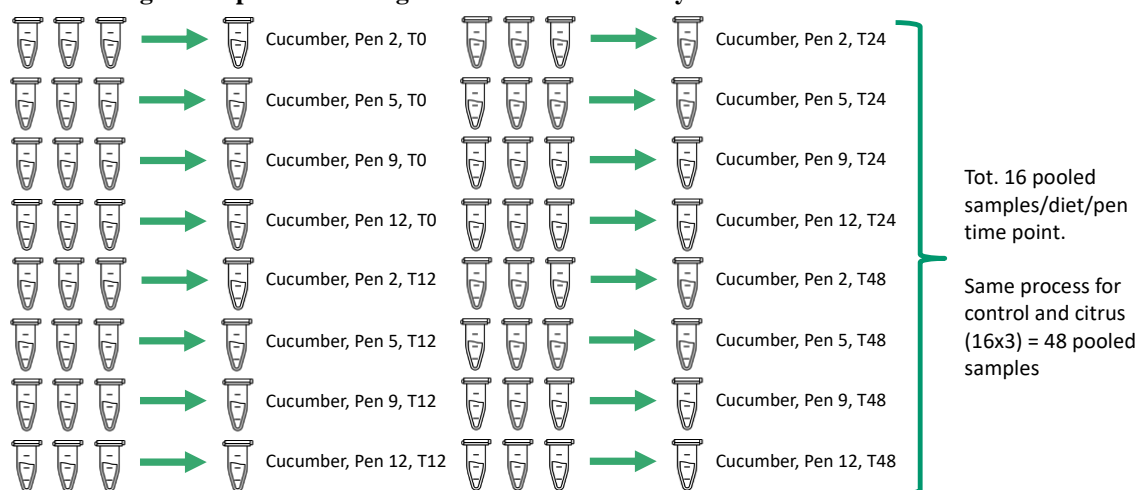

as an example.

Samples were pooled together based on the same diet, pen and time point (N= 48). For any one diet, 12 samples at each timepoint pre and post LPS treatment were selected and mixed into 4 pools with 3 samples per pool to allow statistical analysis so that for each diet there were 16 pooled samples, with one for every timepoint (T0, T12, T24, T48). In total there were 48 pooled samples for the three dietary treatments.

Individual sample study on plasma: Individual plasma samples from trial 2 (see 3.2.1 Trial 2 Experimental design - chapter 3) were randomly selected from CTL and CTS diets only (12 birds/2diet/4 time points) to further investigate the key findings of the pooled analysis. Due to the death of 1 bird at T12h post challenge, a total of 92 individual samples were analysed.

In both studies samples were extracted using the optimized Polyomics protocol; 25µl of plasma was diluted in 975µl of Chloroform/Methanol/Water (1:3:1) at 4°C. Plasma samples were then vortexed for 5 min, centrifuged for 3 min at 13.000g at 4°C and ~800µl of supernatant collected from each sample. For the pooled study, 200µl of 3 unpooled samples, belonging to the same diet/pen and timepoint, were pooled together. Samples were then stored at -80°C until the start of the analysis.

5.3.3 LC-MS/MS analysis

The untargeted LC-MS/MS technique, in conjunction with bioinformatics tools, was used to provide a complete spectrum of metabolites which are modulated by each dietary treatment (CTL, CTS and CMB pooled; CTL and CTS individual samples) and time points pre (T0h) and post challenge (T12,24,48h). Metabolites were first separated by LC, before the MS identification. In Polyomics, where the pooled study on plasma was performed, Hydrophilic interaction liquid chromatography (HILIC) was carried out using their optimised protocol (<https://www.polyomics.gla.ac.uk/assets/downloads/MSMetabolomicsPrepLiquids-Aug2013.pdf>) on a Dionex UltiMate 3000 RSLC system (Thermo Fisher Scientific, Hemel Hempstead, UK) using a ZIC-pHILIC column (150 mm × 4.6 mm, 5 µm column, Merck Sequant). The column was maintained at 25°C and samples were eluted with a linear gradient consisting of 20 mM ammonium carbonate in water (solvent A) and 80% ACN (solvent B) at a flow rate of 0.3 ml/min. The injection volume was 10 µl and samples were maintained at 5°C prior to injection. For the MS analysis, a Thermo Orbitrap QExactive (Thermo Fisher Scientific, Bremen, Germany) was operated in polarity switching mode. MS spectra were acquired in range from m/z 70.0 to m/z 1050.0 with a resolution of 70,000, AGC target 1e6. In the University of Zagreb, where the individual sample study was carried out, the separation was performed with procedure (Rubić et al., 2022), which had been optimised with advice from Glasgow Polyomics, on a ZIC-pHILIC column (150 mm x 4.6 mm, 5 µm column, Merck Sequant, Darmstadt, Germany), at a temperature of 30°C. The LC-MS system runs in a binary gradient solvent mode consisting of 20mM ammonium carbonate (Honeywell, Charlotte, NC, USA) in water (solvent A) and ACN (solvent B) with the flow rate of 0.3 mL/min. 10 µL of each sample were injected and analysis were carried out on a Dionex UltiMate 3000 UHPLC system (Thermo Fisher Scientific, Germering, Germany) coupled to a Thermo Orbitrap QExactive Plus (Thermo Fisher Scientific, Bremen, Germany) in both positive and negative ion modes. Full scan MS spectra were acquired in range from m/z 70.0 to m/z 1050.0 with a resolution of 70,000, AGC target 1e6. In all studies, a quality control (QC) of the LC-MS system was assessed before starting the complete analysis. The QC sample was prepared by mixing equal volumes (15µL) from each sample (CTS, CTL, CMB for the pooled study and CTS, CTL for the individual sample study). This pooled sample was then used to provide a mean profile representing all the analytes during the analysis. The pooled QC sample was injected five times before running the analysis to ensure a proper system equilibrium had been established and then, every 5th

sample to monitor the consistency. The Total Ion Chromatogram (TIC) of the pooled QC sample shown in Figure 5.3, indicates the minimum and maximum signals seen in the positive mode and the interquartile range and shows the spread of the samples over time. Figure 5.4 shows the negative mode plot. Both TIC examples are referred to the plasma pooled study performed in Polyomics, UK. Based on this observation, it's possible to conclude that the instrumentation can perform to nominal standards and provide reproducible data.

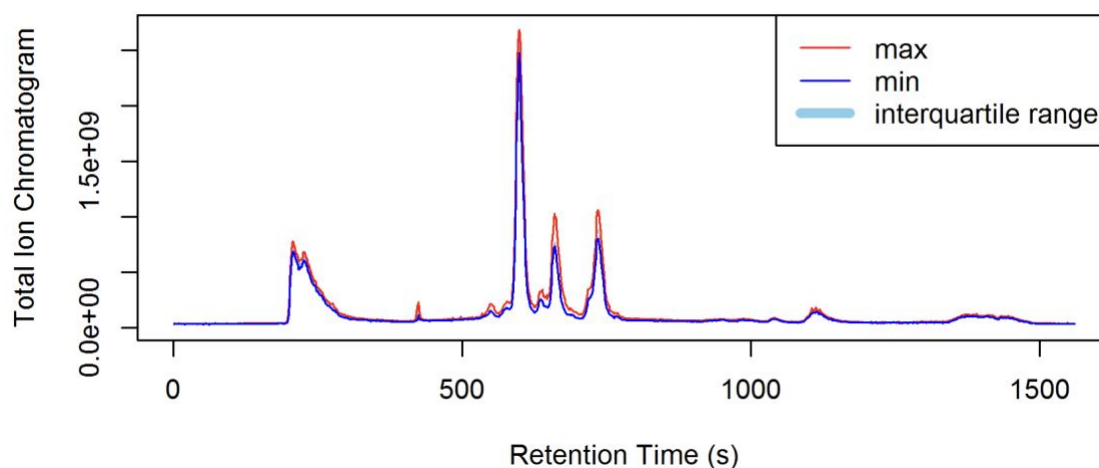

Figure 5.3 Minimum/maximum and interquartile range of the TIC signals for the positive mode pooled samples showing high reproducibility of the instrument over time.

TIC; total ion chromatogram, RT; retention time.

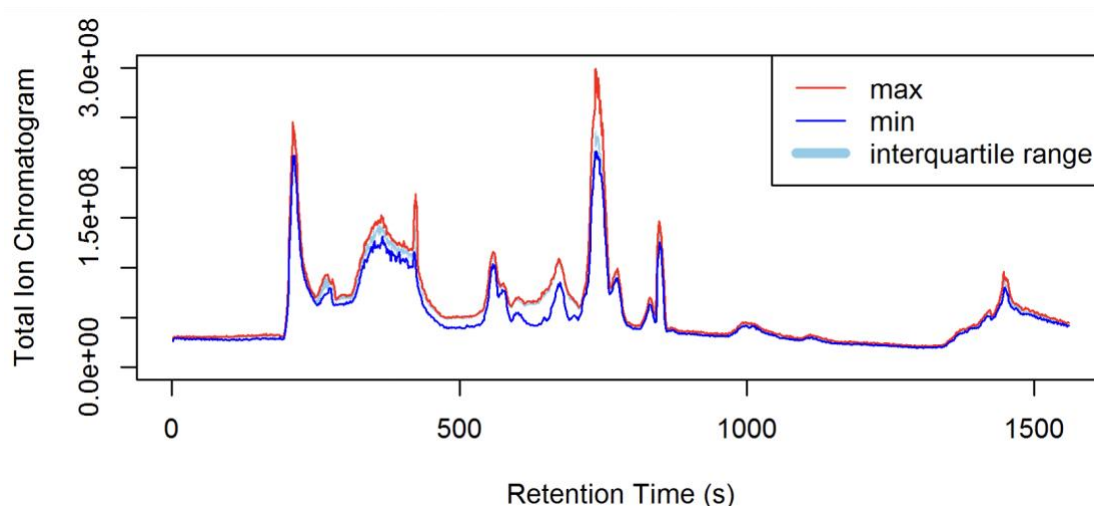

Figure 5.4 Minimum/maximum and interquartile range of the TIC signals for the negative mode pooled samples showing high reproducibility of the instrument over time.

TIC; total ion chromatogram, RT; retention time.

Default Polyomics standards mixes of known metabolites (standards 1, standards 2 and standards 3) were also run in MS to allow the identification of experimental metabolites in both studies. The data/metabolites were peak-detected and noise-reduced. A list of the peaks'

intensities was released at the end of the analysis and the first chromatogram was generated (Rt-m/z data pairs were used as identifiers). Then, data obtained from LC-MS were converted into mzXML format files using the convert tool of Proteo Wizard (msConvertGUI, <http://proteowizard.sourceforge.net/>) and uploaded on PiMP for metabolites identification and Metabonalyt for the statistical analysis. For the overall metabolomics investigations, I pursued the standard work pipeline used by the Glasgow Polyomics facility.

5.3.4 Metabolite's identification Polyomics integrated Metabolomics Pipeline (PiMP)

PiMP software is based on R pipeline (Gloaguen et al., 2017) and it was used to evaluate the preliminary results on the effect of dietary administration and LPS in broilers. The use of PiMP was characterised by the following steps: project administration, data upload, quality control, parameters analysis and data interpretation. The pipeline supports only pairwise and combinatorial comparisons. The following experimental analysis were conducted in the pooled study:

- 3 pairwise comparisons to explore the effects of LPS challenge at all time points irrespective to diet:

CTL_T12 relative to CTL_T0

CTL_T24 relative to CTL_T0

CTL_T48 relative to CTL T0

- 8 pairwise comparisons to explore the effects of experimental diets (CTS and CMB) vs CTL. In the individual sample study only the CTS and CTL diets were compared at T0, T12, T24 and T48:

CTS_T0 relative to CTL_T0

CMB_T0 relative to CTL_T0

CTS_T12 relative to CTL_12

CMB_T12 relative to CTL_12

CTS_T24 relative to CTL_T24

CMB_T24 relative to CTL_T24

CTS_T48 relative to CTL_T48

CMB_T48 relative to CTL_T48

In the individual sample study on plasma the same analysis was applied but limited to considering CTL and CTS diet (CMB was not included, to allow focus on the effect of CTS). Once each analysis was complete, the quality of the data was verified by studying the total ion chromatograms for the datasets. Total ion chromatograms release information on the total detected masses from the instrument. In most cases, a large broad peak is visible towards the end of the chromatogram which is usually a consequence of salty samples using HILIC chromatography. Metabolites are assigned to four categories based on their mass/RT/polarity: identified, identified+fragments, annotated, annotated+fragments. Data from identified compounds matched internal standards used for the analysis by retention time and mass (high reliability and accuracy) while the annotated compounds were assigned putatively based on mass (low reliability and accuracy). Significantly changing compounds (adjusted $p < 0.05$) were listed and detected per each pairwise comparison. Volcano plots were used to evaluate significant metabolites (adjusted $p < 0.05$) per each pairwise comparison. Results were filtered based on the peak (clear or not) and assignment class (identified/annotated). The metabolic maps tab, derived from the Kyoto Encyclopedia of Genes and Genomes database (Keeg), was studied to gain information about the pathways in which metabolites detected were involved. Each Keeg map gives information about the categories (identified/annotated/unknown) of the metabolites involved in the pathway.

5.3.5 MetaboAnalyst: statistical analysis

The online platform MetaboAnalyst (<https://www.metaboanalyst.ca>) is an easy-to-use free online web tool that can be used to analyse Omics data. The platform allows data analysis and data interpretation (Chong and Xia, 2020). The peak intensity table from PiMP was upload in MetaboAnalyst software to perform statistical analysis. Once data were uploaded, missing values were replaced by 1/5 of min positive values of their corresponding variables by default. The assumption for this approach is that missing values are present due to low abundance metabolites. Moreover, as the presence of zero values can cause problem in the following step of data normalization, they are replaced with small values (Steuer et al., 2007). As mentioned above, data normalization was then applied to remove redundancy and it was mainly characterised by two steps: data transformation and data scaling. Data were transformed via a Log10 transformation, and the means were centred and divided by the

value range of each feature. The normalization of data was confirmed by looking at the distribution of samples through the Kernel density plot before and after normalization. Once, data normalization was confirmed, multivariate (PCA and PLSDA) and univariate (one-way ANOVA) analyses was applied. PCA and PLSDA reduced the dimensionality of the complex data set generated from LC-MS analysis because the data matrix was reduced to principal components (PCs) and samples distributed in a defined space; this allowed a better visualization of the effect of dietary treatment and time point pre and post challenge. The metabolites which showed significant differences were studied by one-way ANOVA to identify differences based on dietary treatments and LPS challenge. Fisher's least significant difference method (Fisher's LSD) was used as ANOVA Post hoc test. Results were considered significant with a $p < 0.05$.

Metabolites were studied in the negative and positive ion modes. When MS is coupled with LC, the positive ion mode (+) is generally preferred as more compounds are expected to ionize in this mode (Cech and Enke, 2001). Metabolites detected in the positive ion modes are presented in the results, when not available the negative ion mode is used instead.

5.3.6 Follow-up functional study: Corticosterone assay

Based on the metabolomics data, a corticosterone assay was carried out to examine the hypothesis that adenosine levels were associated to a lower stress status in broilers fed with CTS diet. To evaluate this hypothesis the levels of corticosterone were measured in plasma samples of CTS, CTL and CMB T0h pre challenge. CMB was used as a second control in the analysis. 12 plasma samples per each diet (N=36) were used for this assay (see 3.2.1 Trial 2 Experimental design - chapter 3). Corticosterone was measured using a commercial ELISA kit (Cayman chemical, Ann Arbor, USA, 501320). Samples were extracted and reconstituted following the validated protocol of our laboratory which previously evaluated the extraction efficiency by spiking samples with 10ul H3-labelled cortisol (Lot. 3632075, Perkin Elmer, Boston Massachusetts, USA). In our protocol, 50 μ l of each plasma sample was added into a glass 20 ml tube and mixed with 4 ml of diethyl ether. Samples were placed for 10 minutes on a mechanical shaker and the solvent phase was decanted into a new glass tube after freezing the aqueous phase with a methanol dry ice bath. Then, extracts were evaporated to dryness using a ventilated hot block. Each sample was reconstituted in 600ul of the ELISA buffer of the kit, by shaking for 1hr at RT. Samples were stored at 4°C overnight. The ELISA was run according to the manufacturer's instructions. In brief, serial dilutions of standards: S1 (5000pg/ml), S2 (2000 pg/ml), S3 (800pg/ml), S4 (320 pg/ml), S5

(128 pg/ml), S6 (51.2pg/ml), S7 (20.5 pg/ml), and S 8 (8.2 pg/ml) were prepared. Each plate contained blanks, non-specific binding wells (NSBs), maximum binding wells(B0s), standards and samples which run in duplicate. 100 μ l of ELISA buffer were added to NSBs while 50 μ l were placed in B0s wells. 50 μ l of each standard, blank and sample were placed on the plate. 50 μ l of corticosterone AChE tracer was added to all wells except for the blank. Then, 50 μ l of ELISA Antiserum was placed in each well except the blank, NSBs and B0s. The plate was then stored and incubated overnight at 4°C. The next day, the plate was washed five times using the wash buffer before adding 200 μ l of Elmans reagent to each well. The plate was covered and put in the dark on an orbital shaker. The absorbance was measured by a spectrophotometer at a wavelength of 405 nm in the B0s wells averaged between 0.3-1.5 A.U (blank subtracted). The assay developed in ~90-120 minutes. Absorbance results were calculated by subtracting the absorbance average of blank wells from the standards. The samples concentrations of Corticosterone were calculated using the equation obtained from the standard curve. Statistical analyses were performed in RStudio; ANOVA test was used to evaluate if any differences in terms of corticosterone levels were found in the supplemented diets (CTS or CMB) compared to control.

5.4 Results

5.4.1 Plasma metabolome

Minor differences were discovered between the analysis of pooled samples (results can be consulted in the appendix C at the end of the thesis) and the individual sample study on plasma so the focus here will be on the results obtained from this last one.

5.4.2 Characterising the LPS effect on the plasma metabolome of broilers at T0, T12, T24 and T48 post LPS challenge- CTL diet

In this study, a total of 5316 identified and annotated features were discovered. After processing the peaks annotated/identified based on mass and mass/retention time, 73 unique compounds matched the known standards (identified and identified+fragments metabolites). In the evaluation of LPS challenge, the 3 group-wise comparisons identified differences in fold changes (fc). Each fc was associated to significance statistics. Peaks with an adjusted $p < 0.05$ were considered significant. Each pairwise comparison was studied separately: significant differences on identified and annotated metabolites were found based on LPS challenge at all time points post challenge. Both metabolite categories were filtered based on peak and isoforms evaluations (Table 5.1). The peak evaluation consists in visualise, in the Pimp software, the peak referred to each significant metabolite per pairwise comparison and define it as clear or unclear peak. In most cases there is noise and multiple peaks associated to one metabolite, in this case the feature must be filtered out. The isoform evaluation was aimed to identify the same peak associated to multiple metabolites. In most cases, metabolites which shared the same peak were associated to isoforms of the same metabolite. If different metabolites shared the same peak, the evaluation was made based on the biological interpretation in collaboration with Glasgow Polyomics, University of Glasgow, and University of Zagreb. Annotated and Identified metabolites, post evaluations, are presented in Tables 5.2, 5.3 and 5.4. The full filtered list of identified and annotated metabolites has been uploaded at the University of Glasgow's repository for research data (<http://dx.doi.org/10.5525/gla.researchdata.1272>).

BEFORE peak and isoforms
evaluation

POST peak and isoforms
evaluation

Pairwise comparisons	Identified metabolites	Annotated metabolites	Identified metabolites	Annotated metabolites
CTL T0h vs CTL T12h	52	1317	17	308
CTL T0h vs CTL T24h	30	793	13	187
CTL T0h vs CTL T48h	18	858	7	205

Table 5.1 LPS challenge: pairwise comparisons of T0h vs T12,24,48h and the respective metabolites annotated (assigned putatively on the basis of mass) and identified (matched by mass and retention time to standards) detected before and post peak and isoforms evaluation.

Peak id	Metabolite	Log2 fc	<i>p</i>	Adjusted <i>p</i>	Peak intensity T0h	Peak intensity T12h	Identification
1	Betaine	-0.98	0.0000	0.0000	1704046315	864408838	identified+fragment
48	L-Glutamine	-0.66	0.0000	0.0000	157564731	99997618	identified+fragment
99	L-Arginine	-0.51	0.0000	0.0000	57344499	40226320	identified+fragment
242	L-Valine	-0.29	0.0000	0.0000	23293168	19026420	identified+fragment
249	L-Methionine	-0.78	0.0000	0.0000	27563852	16059557	identified+fragment
263	beta-Alanine	-0.84	0.0000	0.0000	28674370	16069185	identified
291	L-Lysine	1.07	0.0000	0.0000	9706419	20441740	identified
320	L-Tyrosine	-0.64	0.0000	0.0000	17063947	10969979	identified+fragment
1269	L-Glutamate	-0.76	0.0000	0.0000	4080611	2410382	identified+fragment
1401	L-Ornithine	-0.50	0.0000	0.0000	1649963	1164798	identified+fragment
1712	Cytidine	0.84	0.0000	0.0000	625725	1117303	identified
2757	L-Cystine	-0.62	0.0000	0.0000	318502	206611	identified+fragment
1839	citrate	-1.30	0.0001	0.0006	4877544	1981169	identified+fragment
1933	L-Serine	-0.37	0.0002	0.0010	4088694	3154451	identified+fragment
1395	L-Aspartate	-1.25	0.0008	0.0039	429333	180189	identified+fragment
547	thymine	0.75	0.0010	0.0047	452429	760513	identified
126	Orotate	-1.28	0.0070	0.0269	129917	53634	identified

Table 5.2 Significant metabolites in CTL T0h vs CTL T12h in plasma samples

List of significant identified metabolites with the relative Log2 fc, *p*, adjusted *p* and identification. Identified metabolites can match the m/z and RT of features with internal standards (identified) and through the comparisons of fragmentation spectra against mass spectral database (identified + fragment). Metabolites listed in the order of increasing adjusted *p*.

Peak id	Name	Log2 fc	<i>p</i>	Adjusted <i>p</i>	peak intensity T0h	peak intensity T24h	identification
173	beta-Alanine	-0.78	0.0000	0.0000	28674370	16692828	identified
235	L-Tyrosine	-0.97	0.0000	0.0000	17063947	8694339	identified+fragment
662	L-Glutamate	-0.72	0.0000	0.0000	4080611	2483110	identified+fragment
1	Betaine	-0.54	0.0001	0.0014	1704046315	1175697621	identified+fragment
47	L-Glutamine	-0.45	0.0002	0.0021	157564731	115120831	identified+fragment
991	Cytidine	-0.68	0.0003	0.0028	625725	390525	identified
3095	thymine	0.29	0.0003	0.0032	452429	551328	identified
231	Hypoxanthine	-0.77	0.0003	0.0034	16841451	9850372	identified+fragment
4562	Homocystine	-0.75	0.0005	0.0051	41814	24783	identified
73	L-Arginine	-0.47	0.0009	0.0076	57344499	41398532	identified+fragment
843	L-Ornithine	-0.61	0.0012	0.0187	1649963	1078471	identified+fragment
167	L-Valine	-0.45	0.0031	0.0221	23293168	17034966	identified+fragment
170	L-Methionine	-0.46	0.0068	0.0416	27563852	20095208	identified+fragment

Table 5.3 Significant metabolites in CTL T0h vs CTL T24h in plasma samples

List of significant identified metabolites with the relative Log2 fc, *p*, adjusted *p* and identification. Identified metabolites can match the *m/z* and RT of features with internal standards (identified) and through the comparisons of fragmentation spectra against mass spectral database (identified + fragment). Metabolites listed in the order of increasing adjusted *p*.

Peak id	Name	Log2 fc	<i>p</i>	Adjusted <i>p</i>	peak intensity T0h	peak intensity T48h	identification
1204	Adenosine	-2.13	0.0000	0.0000	336284	76640	identified+fragment
4562	Homocystine	-0.69	0.0001	0.0012	41814	25914	identified
843	L-Ornithine	-0.57	0.0002	0.0021	1649963	1114771	identified+fragment
3095	thymine	0.40	0.0003	0.0027	452429	598945	identified
662	L-Glutamate	-0.31	0.0008	0.0061	4080611	3288425	identified+fragment
170	L-Methionine	-0.38	0.0027	0.0175	27563852	21183247	identified+fragment
231	Hypoxanthine	-0.50	0.0064	0.0371	16841451	11892666	identified+fragment

Table 5.4 Significant metabolites in CTL T0h vs CTL T48h in plasma samples

List of significant identified metabolites with the relative Log2 fc, *p*, adjusted *p* and identification. Identified metabolites can match the m/z and RT of features with internal standards (identified) and through the comparisons of fragmentation spectra against mass spectral database (identified + fragment). Metabolites listed in the order of increasing adjusted *p*.

KEGG maps from PiMP were used to study metabolic pathways in which identified metabolites were involved. Four metabolic pathways: were confirmed to be influenced by LPS and studied in detail: Alanine, Aspartate, Glutamate; Glycine, Serine, Threonine; Methionine and Cysteine; Arginine and Proline. The identified and annotated metabolites in each KEGG maps were studied and evaluated.

Note that the entire pathways described below were confirmed to be modulated in both the pooled (appendix C) and individual sample study. In each pathway, identified (yellow dot), annotated (grey dot) and unknown (white dot) metabolites are represented. Metabolites circled in red represent the ones which are confirmed, post peak evaluation, to be significantly decreased by LPS challenge at T12h (Figure 5.5A, B, C, D, E).

- **In alanine, Aspartate and Glutamate pathway:** L-Alanine, L-Aspartate, L-Asparagine, D-Aspartate, L-Glutamine, L-Glutamate were confirmed to be significantly decreased by LPS at T12h post challenge (Figure 5.5A).
- **In Glycine, Serine and Threonine pathway:** Cystathionine, Betaine, Sarcosine, Threonine and L-Aspartate were decreased at T12h post challenge (Figure 5.5B).
- **In Cysteine and Methionine pathway:** Sulfate, O-Acetyl-L-Serine, L-Cysteine, L-Alanine, L-Aspartate, L-Cystathionine, L-Serine, L-Homocysteine, L-Methionine-S-oxide, L-Methionine were found significantly decreased by LPS at T12h post challenge (Figure 5.5C).
- Intermediates of the **Krebs's cycle:** Citrate, (S)-Malate, Cis-Aconitate were also found significantly decreased in the first 12h post LPS challenge (Figure 5.5D).

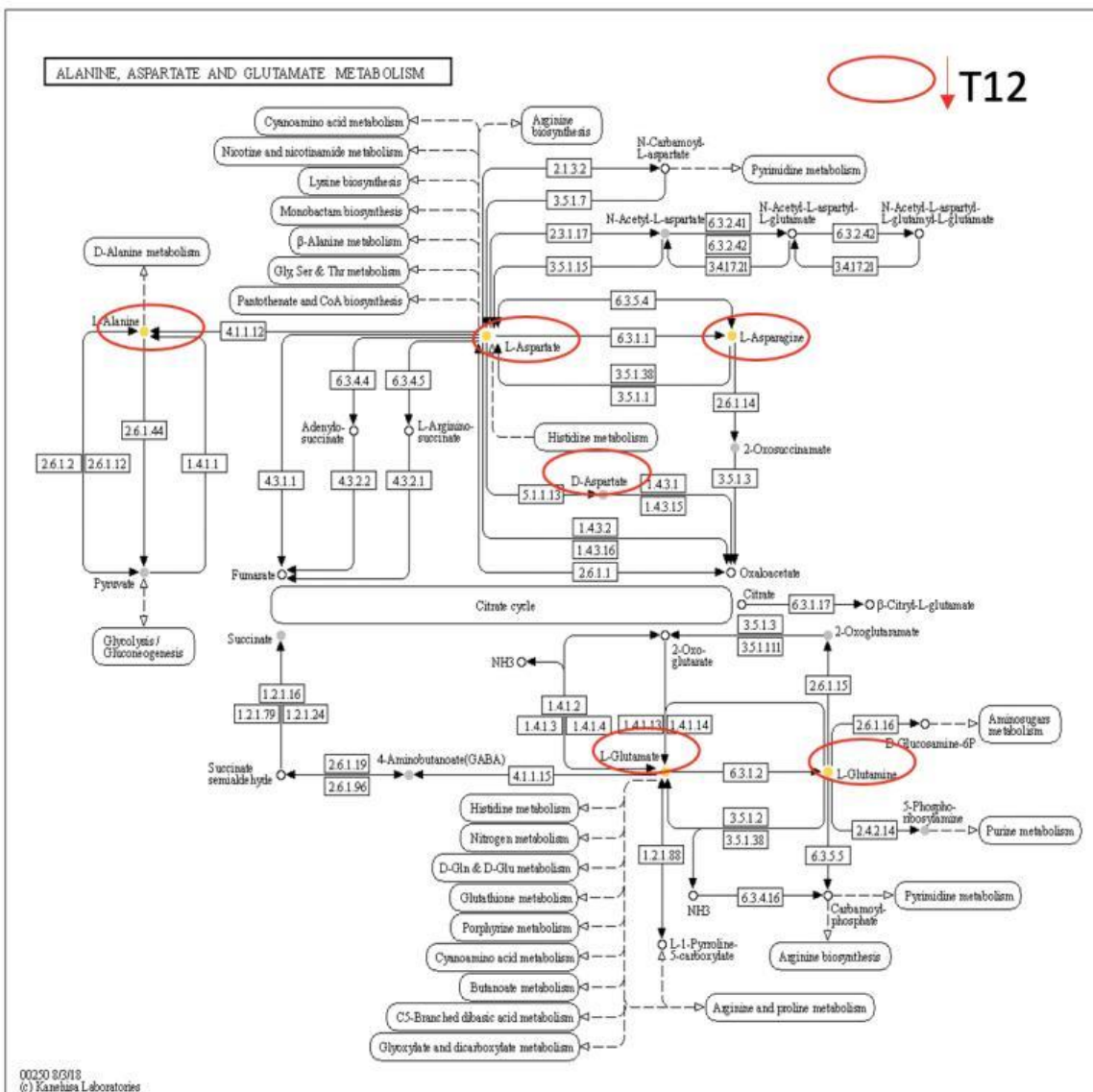

00250 8/3/12
(c) Kanehisa Laboratories

A

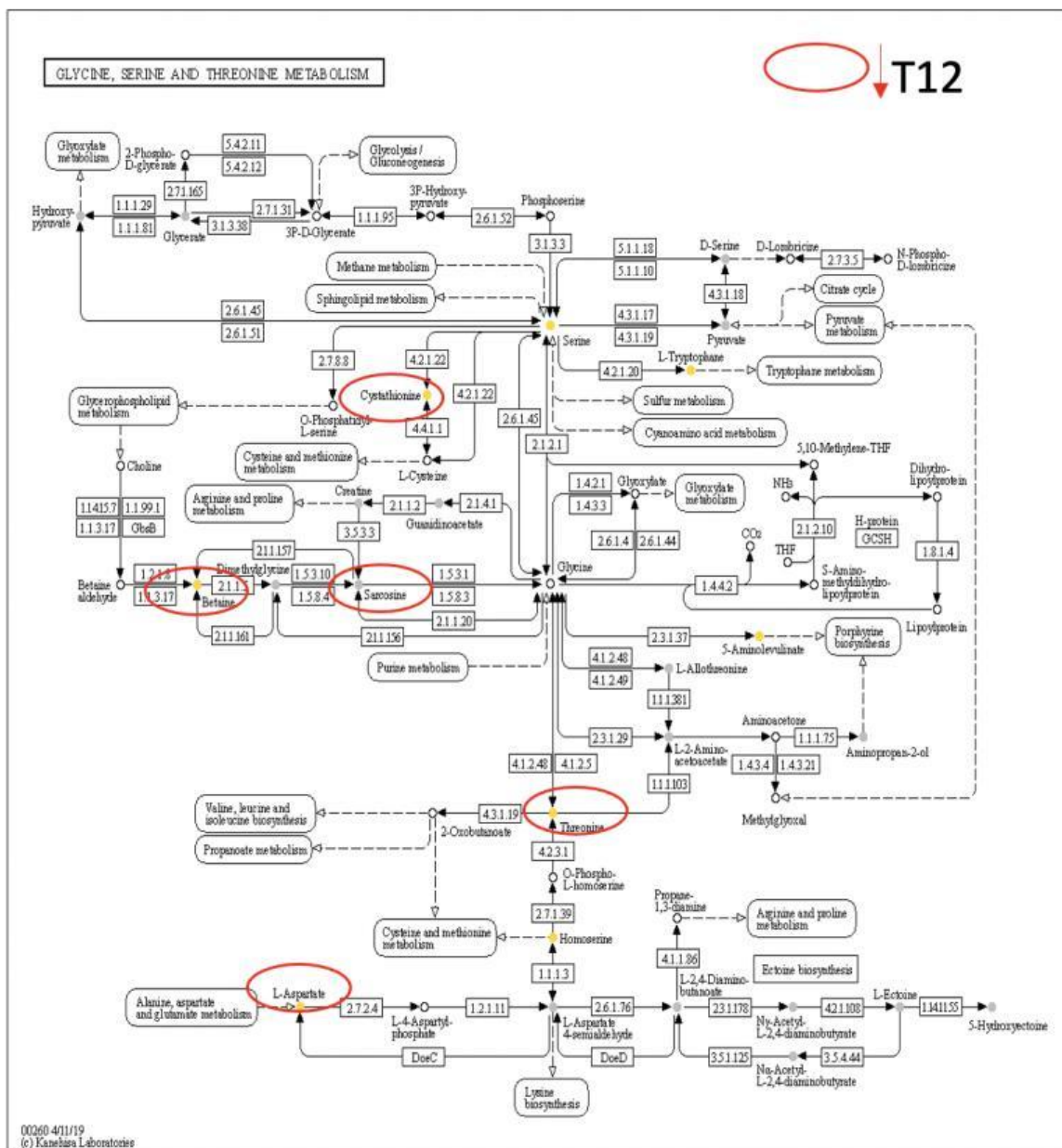

B

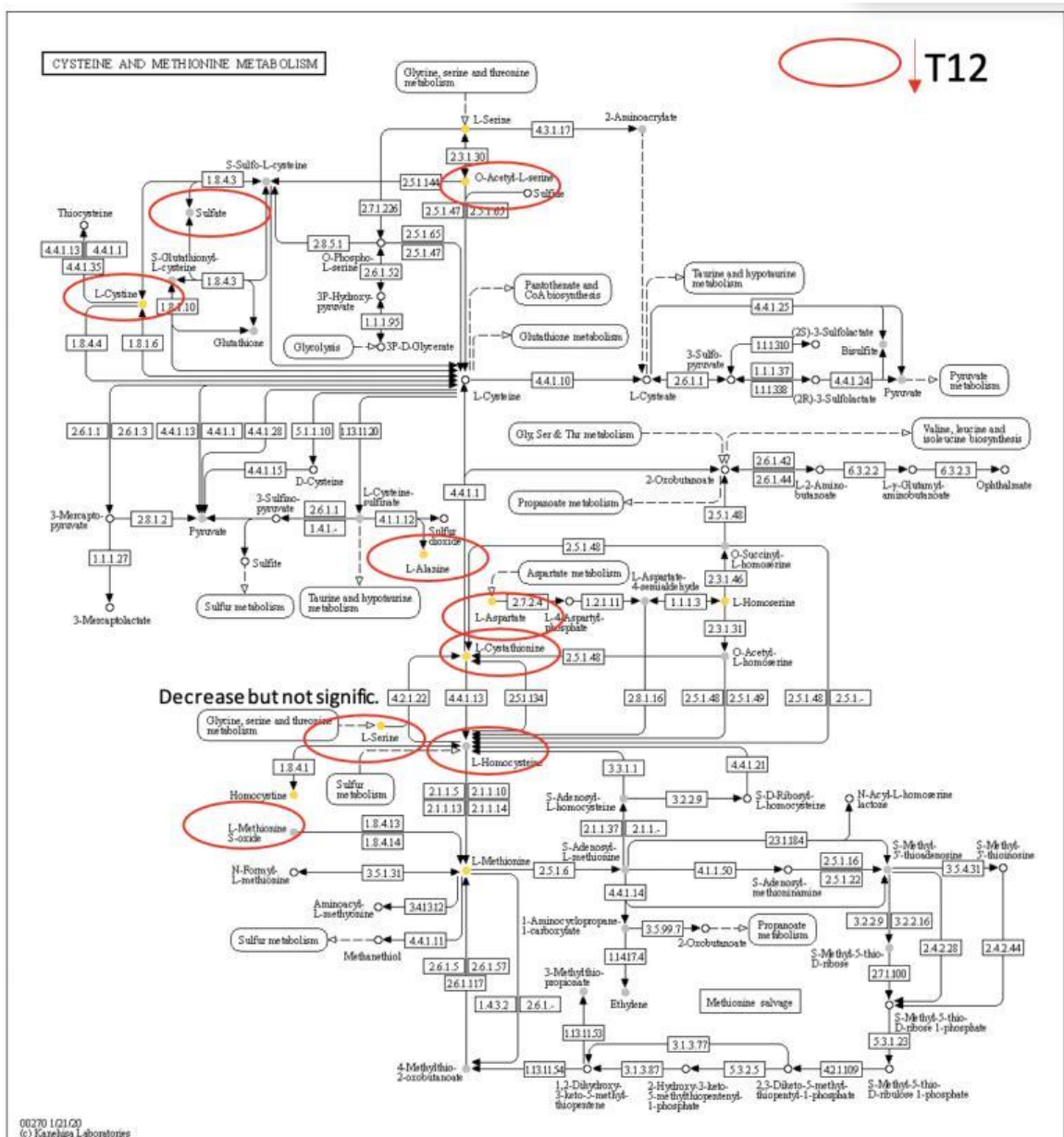

C

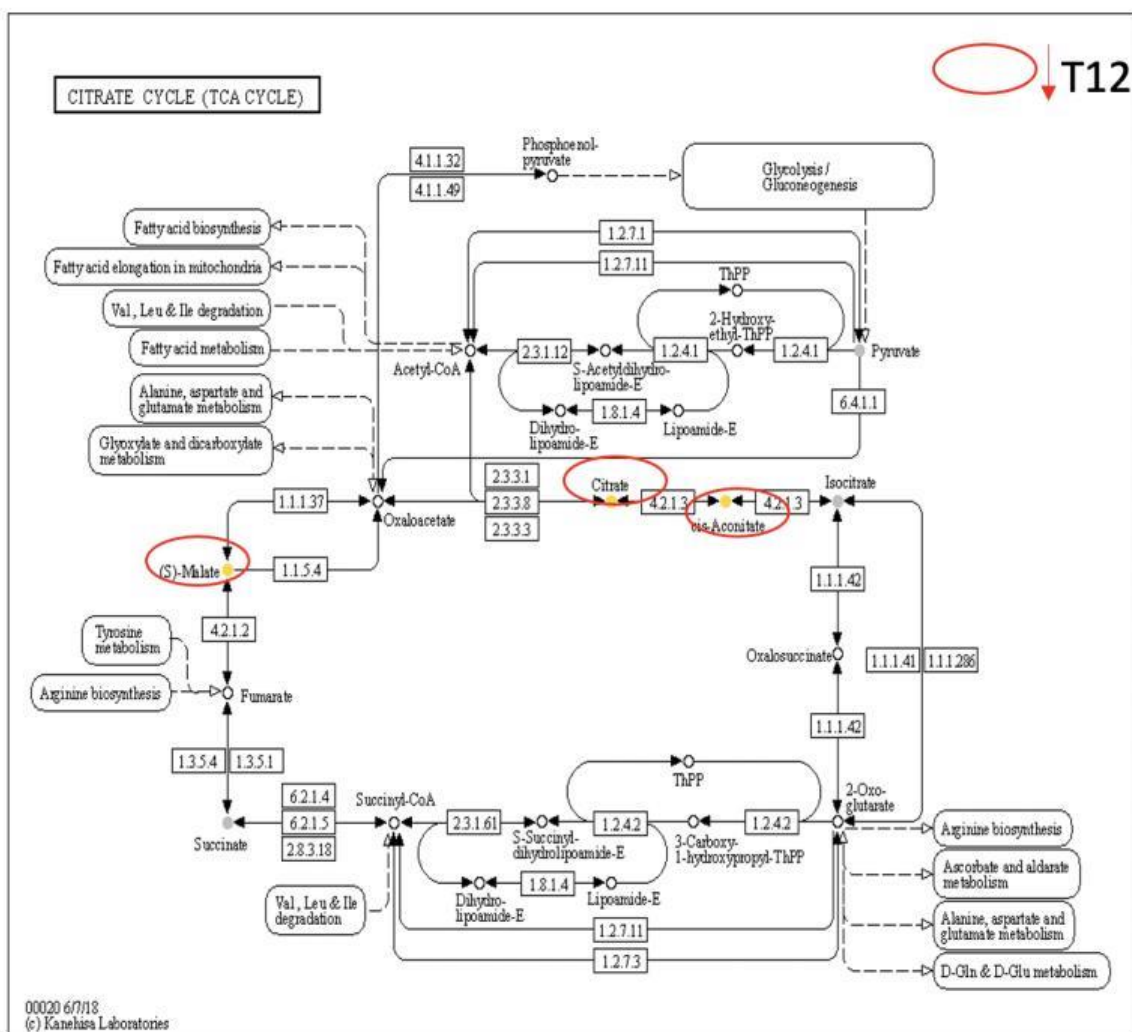

D

Figure 5.5 KEGG pathways influenced by LPS challenge.

Alanine, Aspartate and Glutamate pathway (Figure A), Glycine, Serine and Threonine pathway (Figure B), Cysteine and Methionine pathway (Figure C) and the Citrate cycle (Figure D) are represented. In all pathways, red circles indicate intermediates significantly decreased at T12h post challenge compared to T0h pre challenge. Yellow dots indicate identified metabolites, grey dots indicate annotated metabolites and white dots unknown metabolites.

Following data normalization in MetaboAnalyst, multivariate analysis using PCA and PLSDA shown in Figure 5.6, confirmed that LPS significantly modulated the entire metabolome of broilers at all time points. In PCA, samples clearly cluster a at T0h and T12h post LPS challenge while minor differences are observed between T24h and T48h. In PLSDA, samples at each time point cluster separately.

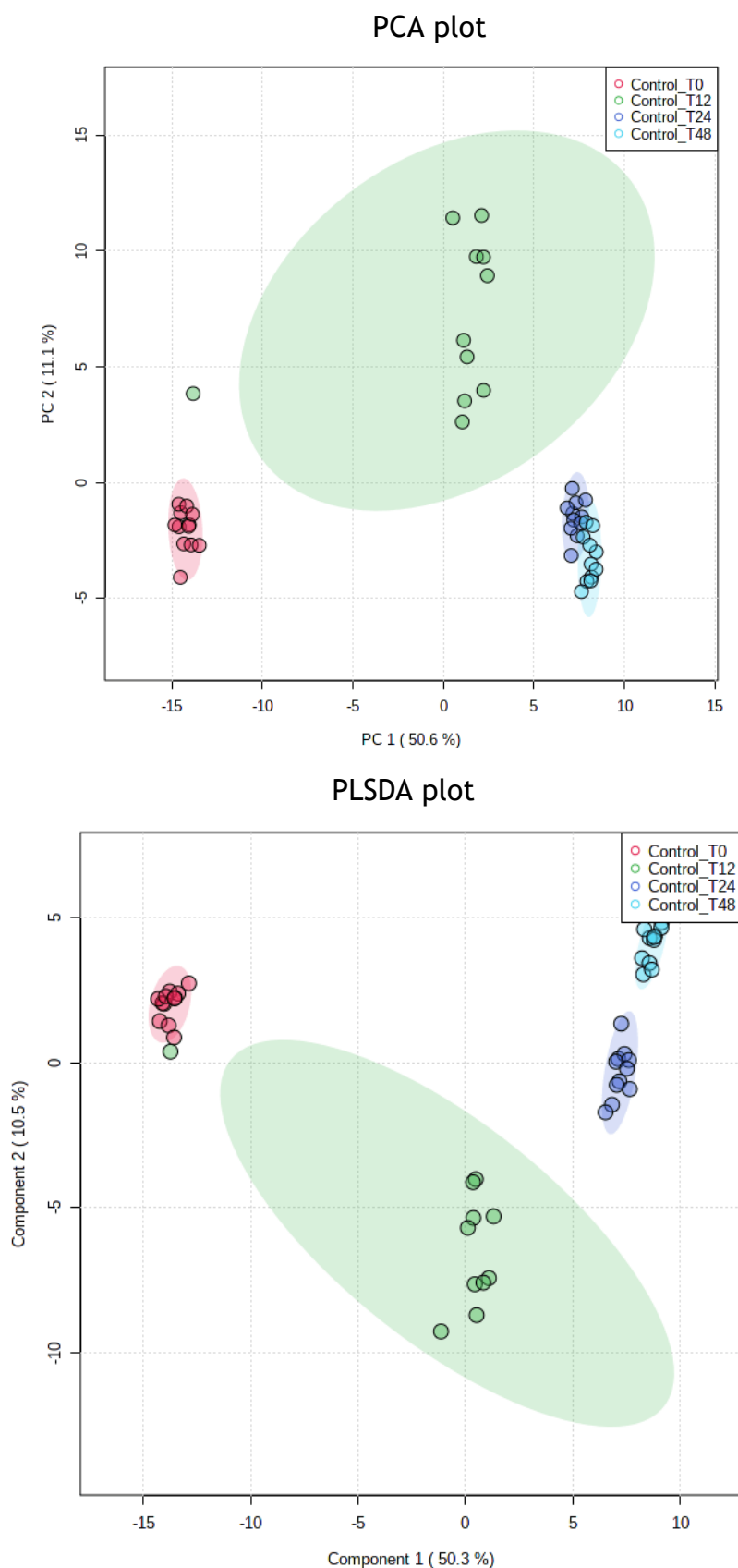

Figure 5.6 PCA and PLSDA of samples belonged to CTL diets at time points 0,12,24 and 48h pre and post challenge.

In PCA, samples clustered depending on LPS at all time points with a clear difference at T0h and T12h post challenge (minor differences are observed between T24h and T48h). In PLSDA, all time points clustered separately. In both multivariate analyses, LPS shifted the overall metabolome composition post challenge.

Metabolites which were considered more interesting, in terms of their biological role and the pathway in which they are involved, were studied in detail. For example, essential amino acids such as Cysteine and Methionine and intermediates of Citrate cycle such as Citrate and (S)-Malate. All these metabolites showed a decrease in their abundance due to LPS injection in the first T12h. Then the abundance was found restored after 24/48h (Figure 5.7).

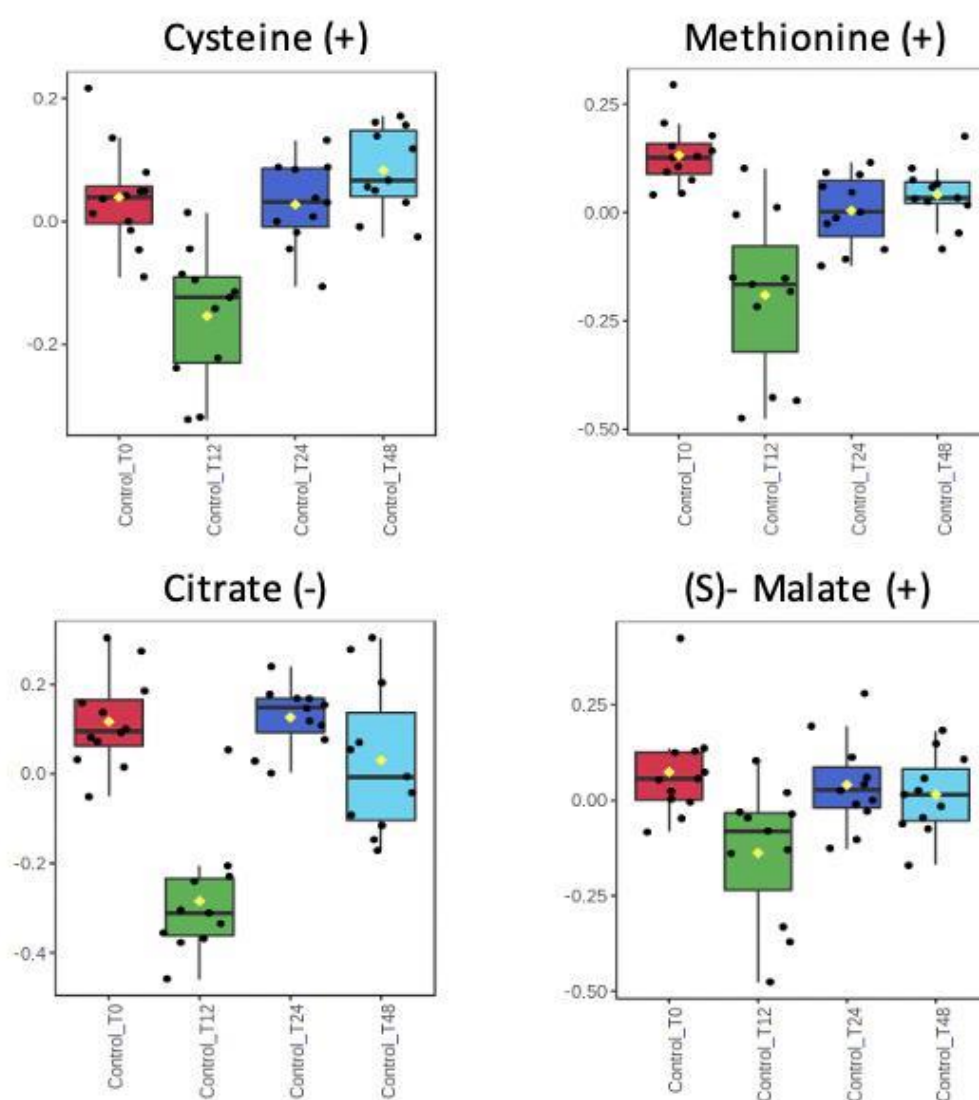

Figure 5.7 Cysteine, Methionine, Citrate and (S)- Malate, pre (T0h) and post (T12,24,48h) LPS challenge in CTL diet.

The box and whisker plots (mean \pm SD) referring to CTL diet at each timepoint summarize the normalized values of Cysteine, Methionine, Citrate and (S)-Malate intensities. Both metabolites resulted to be significantly decreased ($p < 0.05$) at T12h compared to T0,24,48h. (+) and (-) indicate the ion mode in which metabolites are detected.

5.4.3 Plasma metabolome: dietary effect

In the pooled samples study no differences were discovered comparing CMB vs CTL diet (appendix C), for this reason only CTS vs CTL diet comparisons were compared in the complete study. The 4 group-wise comparisons identified significant changes mainly associated to the annotated category of metabolites; peaks with an adjusted $p < 0.05$ were considered significant. The overall list of annotated and identified metabolites was studied and filtered based on peak and isoform's evaluation. Metabolites at T0 and T48 hours post challenge were either regulated upwards or downwards by CTS while most metabolites at T12 hours were found to be increased by CTS (mainly belonging to amino acids metabolism) (Table 5.5). The full filtered list of annotated metabolites has been uploaded at the University of Glasgow's repository for research data (<http://dx.doi.org/10.5525/gla.researchdata.1272>).

Pairwise comparisons	BEFORE peak and isoforms evaluation		POST peak and isoforms evaluation	
	Identified metabolites	Annotated metabolites	Identified metabolites	Annotated metabolites
CTL T0h vs CTS T0h	1- Adenosine	260	1- Adenosine	76
CTL T12h vs CTS T12h	1- Adenosine	199	1- Adenosine	47
CTL T24h vs CTS T24h	0	7	0	0
CTL T48h vs CTS T48h	1- Adenosine	218	1- Adenosine	45

Table 5.5 Pairwise comparisons of CTL vs CTS diet at each time point (T0,12,24,48h) and the respective annotated and identified metabolites detected before and post peak and isoforms evaluation.

The overall metabolome modulation was studied through multivariate analysis in MetaboAnalyst, PCA and PLSDA, as presented in Figure 5.8. In PCA plot, samples clearly clustered separately based on diet (CTS vs CTL) mainly at T0h and T12h compared to T24 and 48h. PLSDA identified similar clusters at T0h and T12h and highlighted a minor shift of metabolome composition in the first T12h post LPS challenge in CTS diet compared to CTL.

PCA plot

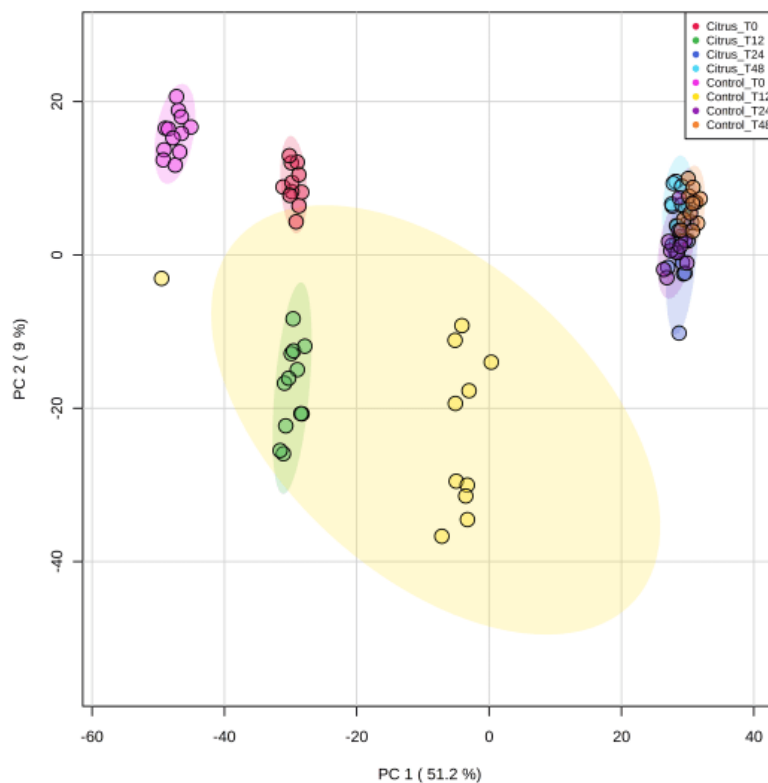

PLSDA plot

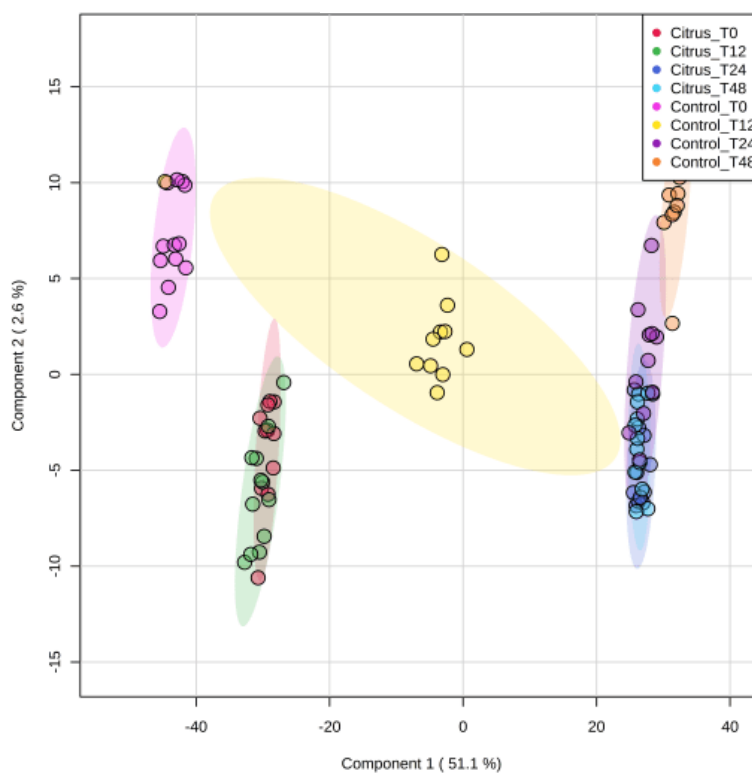

Figure 5.8 PCA and PLSDA of samples belonged to CTS and CTL diets at time points 0,12,24 and 48h pre and post challenge.

In PCA, samples clustered depending on dietary treatments mainly at T0h and T12h post challenge while minor differences are observed at T24h and T48h. In PLSDA, samples belonging to CTS diet at T0h and T12h post challenge showed minor changes compared to the CTL diet at the same time points. In both multivariate analyses, LPS shifted the overall metabolome composition at all time points post challenge.

Based on these data, a wide range of metabolites were found to be influenced by CTS diet. The results were found comparable to the plasma pooled study (appendix C). Despite the high number of metabolites modulated by CTS diet, Adenosine was the only identified metabolite that significantly differed between the two groups. The concentration of Adenosine was significantly lower (adjusted $p < 0.05$) at T0h in broilers fed with CTS diet compared to CTL diet. Then its level significantly increased after T12h and remained stable at T24h and T48h. In the case of the CTL diet, the level of Adenosine started higher then decreased after T24h leading to a significantly lower concentration at T48h compared to CTS diet (Figure 5.9).

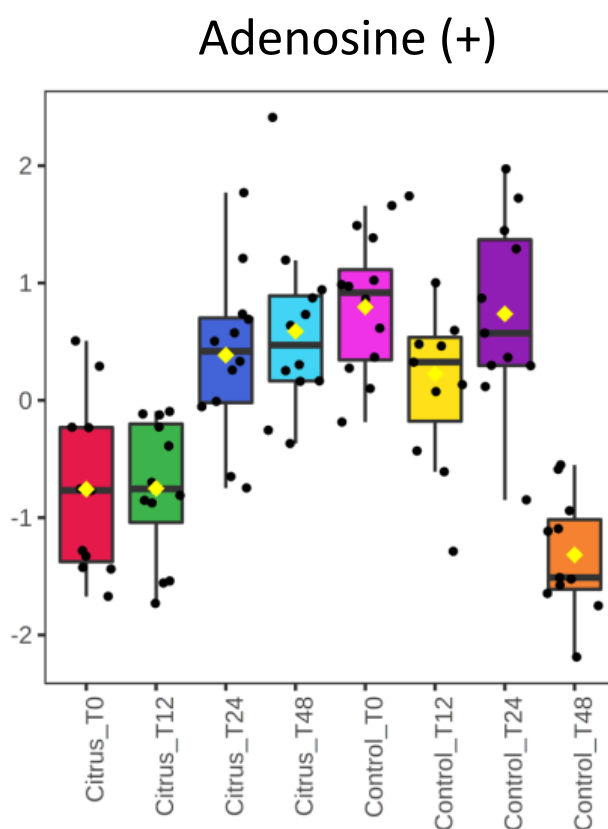

Figure 5.9 Adenosine intensity of samples at T0,12,24 and 48 in CTL and CTS diets

The box and whisker plots (mean \pm SD) referring to each diet and timepoint summarize the normalized intensities of Adenosine intensity per each group. The metabolite was detected in the positive (+) ion mode. The level is significantly lower at T0h and T12h in broilers fed with CTS diet compared to CTL while at T48h birds on the CTL diet displayed a significantly lower level of adenosine compared to CTS ($p < 0.05$). This metabolite is shown in the positive ion mode (+).

5.5 Functional study: Corticosterone assay

Table 5.6 compares the mean and SE concentration of corticosterone (ng/ml) in plasma collected at T0 (pre LPS challenge) from (N=12 per diet, CTL, CTS or CMB). No significant difference was observed between dietary treatments.

	<i>Diet</i>	<i>N</i>	<i>Mean</i>	\pm	<i>SE</i>
<i>Corticosterone (ng/ml)</i>	CTL	12	2.979	\pm	0.443 ^a
	CTS	12	2.615	\pm	0.409 ^a
	CMB	12	3.772	\pm	0.593 ^a

Table 5.6 Corticosterone concentrations (ng/ml) in plasma of broilers fed different dietary regimes at T0 (pre LPS challenge).

The data show the mean \pm SE of the corticosterone concentration in CTL, CTS and CMB groups. The groups that share the same letters indicate that no significant difference is displayed among groups; No significant differences were discovered based on different dietary administration.

5.6 Discussion

In this investigation, the initial pooled study was used as a basis for sample selection for the individual sample study in order to keep the cost of the MS analysis within budget. The samples from the CMB diet were compared to the CTL diet in the pooled study but the results showed that this diet was not effective in term of metabolites modulation. This was the justification for not including the CMB diet in the individual sample study. Regarding the LPS challenge and CTS dietary influence, results of both studies were found to be comparable with just minor differences; for this reason the results of the individual sample study on CTL and CTS form the basis for this discussion. This result also adds to the evidence base that conducting pooled sample studies is justifiable especially where consumable and timing constraints are a limiting factors although individual sample studies are more appropriate when possible (see Discussion in chapter 6).

Here below the effects of LPS challenge and modulating effects of the CTS diet on broilers plasma metabolome are discussed by first comparing the results with the existing literature and then providing a biological interpretation of data.

Effects of LPS on the plasma metabolome

LPS was found, in both studies (pooled and individual sample study), to modulate the broilers plasma metabolome at all time points post challenge. The strongest impact was observed at T12h which corresponds to the highest malaise of broilers and initiation of the APR based on our time points as demonstrated by increases of at least two major APPs, SAA and ex-FABP (see chapter 3) (Horvatić et al., 2019). In the first T12h post challenge, metabolism of many amino acids was greatly affected with Alanine, Aspartate, Glutamate/ Glycine, Serine, Threonine/Methionine and Cysteine/ Arginine and Proline being identified the most identified and annotated intermediate metabolites found. LPS triggers immune activation by activating the inflammatory pathway that involve the production of cytokines and chemokines (Koppenol et al., 2015). Due to the metabolic effort of activating the immune system and the sickness induced reduction of feed intake, broilers face a generalized dysregulation of nutrient homeostasis which leads to an imbalance in essential amino acids during endotoxemia (Lieboldt et al., 2016). According to Asai et al. (2008) the lack of energy intake promotes the degradation of amino acids to produce energy. As a consequence, a decrease in plasma free amino acid during the early phase post LPS injection is generally registered in plasma (Barnes et al., 2002).

In this study Intermediates of the Citrate cycle were also modulated by LPS: Citrate, 2-Oxo-glutarate, (S)-Malate, Cis-Aconitate were also found to significantly decreased in the first 12 hours post challenge. During inflammation, LPS induces a significant decrease in the expression of genes involved in mitochondrial energy metabolism (Williams and O'Neill, 2018); Glycolysis is upregulated to generate more ATP and intermediates from the pentose phosphate pathway are needed to produce a range of inflammatory mediators (Soto-Herederó et al., 2020). Mitochondrial enzymes involved in the Krebs cycle are inhibited and the Citrate cycle shifts from a catabolic pathway to anabolic pathway (Martínez-Reyes and Chandel, 2020). Thus Citrate is withdrawn from the cycle and is exported from mitochondria to the cytosol, where it is cleaved into acetyl-CoA and Itaconate (Williams and O'Neill, 2018). Our findings were found in line with Wu et al. (2021) that used a broilers challenge experimental model and demonstrated that LPS can modulate entire amino acid pathways.

Effects of CTS diet on plasma metabolome pre and post LPS challenge

CTS diet was found to modulate the metabolome of broilers under normal physiological conditions (T0h) as well as during the LPS stimulation of the immune response, mainly in the first T12h post injection. However, difficulty in analysing these data occurred mainly because many metabolites were assigned to the annotated category which means that the metabolite identification was difficult as many metabolites were associated with the same peak. To overcome this problem, a future study using different standard mixes could help in interpreting results and may allow better detection and identification of metabolites. Another large number of metabolites modulated by CTS diet were assigned to the unknown category, which made it impossible to formulate any plausible hypothesis. Despite these difficulties, some considerations are given to the annotated metabolites modulated by CTS pre and post challenge below. The main reason of these changes, before LPS challenge, could be attributed to the effects of bacterial strains found influenced by CTS diet. As demonstrated in chapter 2, CTS can influence the abundance of different beneficial bacterial strains such as lactic acid bacteria at the jejunum level of broilers. Lactic acid bacteria can decompose proteins to produce a variety of small molecule peptides or free amino acids (Wang et al., 2021). Similarly, other bacterial strains could have influenced amino acids, lipids or secondary metabolites but no information are available in the literature so further investigation is required to clarify this aspect. In the first 12 hours post LPS challenge, broilers fed with CTS diet showed an increase in many annotated metabolites involved in

the amino acids' and carbohydrates metabolism. When lack of energy occurs, because of LPS (see Effects of LPS on plasma metabolome), muscles are entitled to degrade amino acids for energy needs but broilers fed with CTS show higher protein and carbohydrates availability.

However, our attention was focused on the main identified metabolite, Adenosine, which has an interesting biological role. Adenosine is a purine nucleoside formed by Adenine and Ribose, and plays an important role in the modulation of the immune system of humans and animals (Haskó, 2004). During inflammation or as a result of stress Adenosine levels in plasma dramatically increase by the breakdown of adenosine triphosphate (ATP) (Antonioli et al., 2019) (Figure 5.10).

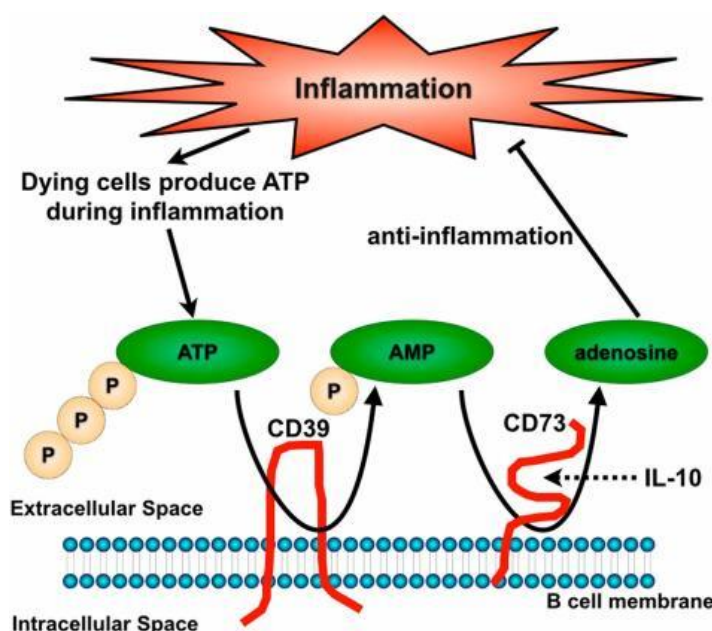

Figure 5.10 Adenosine production during inflammation or as a result of stress.

During inflammation or pathological changes, Adenosine is produced by ATP dephosphorylation in the extracellular spaces. This is transformed into adenosine monophosphate (AMP) by the ectonucleoside triphosphate diphosphohydrolase- 1 (also named CD39). AMP is then successively dephosphorylated by the enzyme ecto-5'-nucleotidase (CD73) to form Adenosine which decreases proinflammatory cytokine release while increasing the secretion of IL-10 (modified from Antonioli et al., 2019).

Alternatively, Adenosine can be generated through the pathway nicotinamide adenine dinucleotide (NAD⁺) and CD38 enzyme that converts extracellular NAD⁺ into adenosine diphosphate ribose (ADPR) which is transformed by CD203a into AMP. Then, AMP can be dephosphorylated by the enzyme CD73 to form Adenosine (Antonioli et al., 2019). The main action of Adenosine is then determined by its interaction with four receptors A₁, A_{2A}, A_{2B}, A₃ which are expressed on the surface of immune cells (e.g macrophages and monocytes); each receptor has a different direct action on the cAMP metabolism and consequently the

modification of secondary metabolic pathways (Koupenova and Ravid, 2013). With respect to the current study adenosine was found to be lower in the plasma at T0 in birds fed the CTS diet. This led to the hypothesis that certain active compounds in the CTS diet, such as flavonoids or pectin, improved the health and wellbeing of broiler chickens compared to those on the CTL diet. For this reason, a functional study, aimed to evaluate plasma Corticosterone concentrations (biomarkers of stress inflammation conditions) was performed, but no differences in corticosterone levels were observed based on different dietary administration.

An alternative hypothesis is that the difference in adenosine concentration in CTS vs CTL (and CMB diets) at T0h and T12h post LPS challenge may result from the associated interactions of CTS active compounds, such as pectin with Galactin-3 (Gal-3). Gal-3 are carbohydrate binding proteins belong to lectin families which are highly expressed in monocytes, macrophages and dendritic cells (Barondes et al., 1994). In mice, during inflammation, Gal-3 passes into the extracellular space to active the inflammatory response but in the presence of citrus pectin, Gal-3 is inhibited and the pro-inflammation pathway is blocked (Nangia-Makker et al., 2002). The mechanism described above leading to an increase in Adenosine is uninitiated. No available information is available in the literature on broilers chickens, but a possible relation between pectin and the suppression of the inflammatory pathway could explain differences in Adenosine concentrations.

Another hypothesis would be that other active CTS compounds, such as flavonoids (quercetin or hesperidin) or limonene, could interact with the Adenosine pathway or its receptors. In humans, quercetin can inhibit the enzyme CD73 (Braganhol et al., 2007) which would cause a lower production/inhibition of Adenosine during LPS inflammation. Hesperidin is an agonist of A₁, A_{2A} receptors (Muhammad et al., 2019) and their interaction could determine an increase in free circulating adenosine. Limonene, is demonstrated to be agonist of A_{2A} receptors as well (Park et al., 2011) (Figure 5.11). The affinity of flavonoids and limonene to Adenosine receptors suggests that CTS diet may potentially block the effects of Adenosine and determine an increase in free extracellular Adenosine levels as the receptors site is occupied by the interaction of CTS compound.

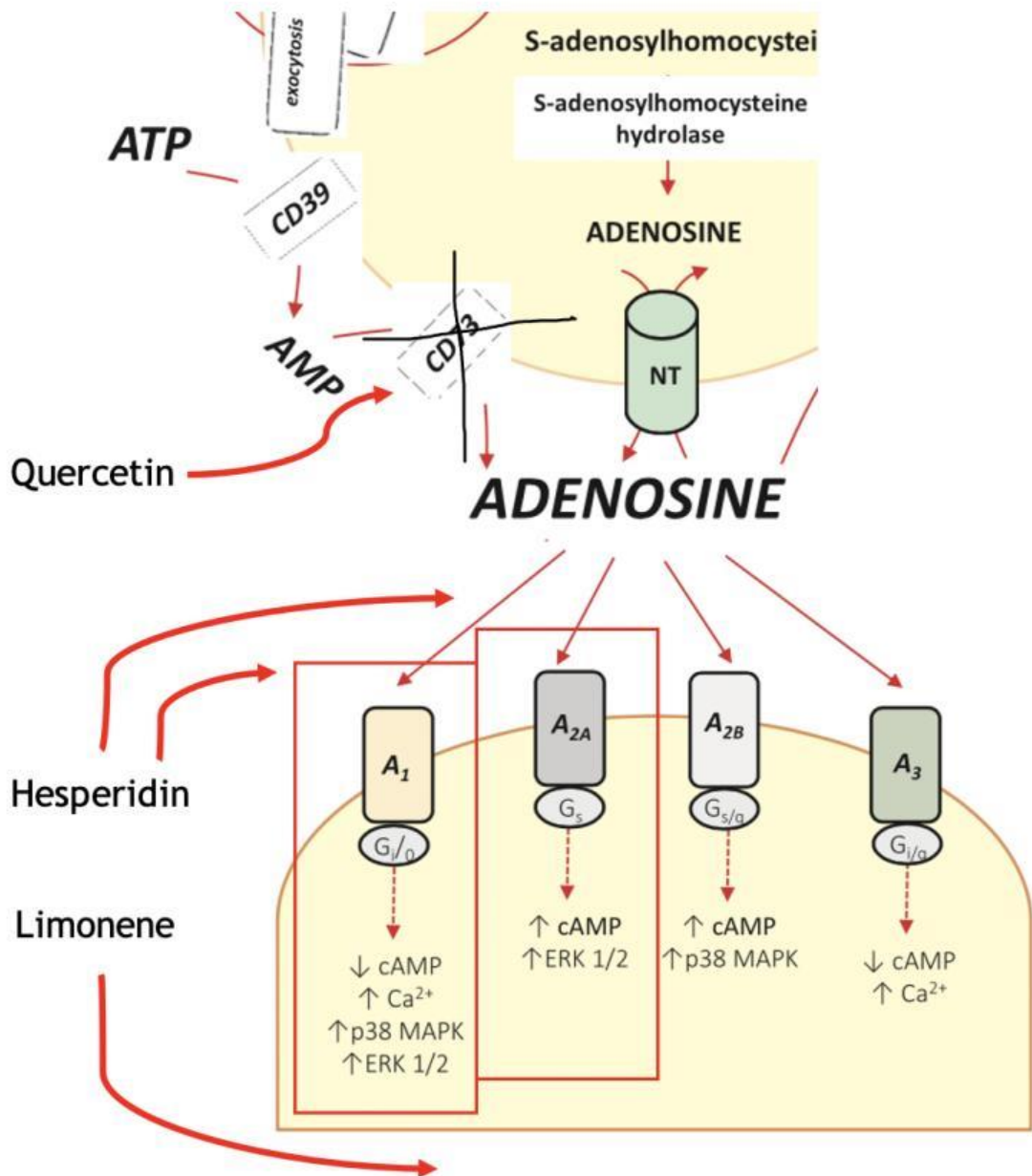

Figure 5.11 Interaction between CTS compounds (quercetin, hesperidin, and limonene), adenosine and its receptors A₁, A_{2A}, A_{2B}, A₃.

CD39-CD73 led to the formation of adenosine and its action it's on A₁, A_{2A}, A_{2B}, A₃ receptors. Quercetin can inhibit the enzyme CD73 leading to a decrease the production of Adenosine. Hesperidin is agonist of A₁, A_{2A} receptors while Limonene is agonist of A_{2A} receptors (modified from Antonioli et al., 2019).

Conclusions

LPS endotoxin was found to modulate the overall plasma metabolome of broilers at all time points post challenge with a major impact at T12h which corresponds to the peak of the innate immune response based on the levels of two major APPs (see chapter 3). Multiple amino acids and carbohydrate metabolites were found to be significantly modulated by LPS because it promotes the degradation of amino acids and shifts the Citrate cycle from a catabolic pathway to anabolic pathway.

CTS diet was found to have a strong modulation on plasma metabolome at T0 and T12h pre and post challenge by observing PCA and PLSDA, many other metabolites were also changed but most were labelled as unknown or annotated metabolites which made a clear interpretation problematic. However, CTS appears to increase amino acids abundance as a sign of higher energy and protein availability. The abundance of the main identified metabolite, Adenosine, was found influenced by a possible interaction between the metabolite and CTS bioactive compounds such as pectin, flavonoids, and limonene. Our biological interpretation of the Adenosine metabolite makes CTS compounds good candidates in modulating the immune response of broilers during inflammation. However, the mechanism of action needs to be clarified. The proteomics data described in chapter 4 suggests a possible interaction between CTS compounds and their influence in reducing the abundance of proteins involved in the immune response of broilers. The investigation on metabolites in which liver metabolic enzymes, identified by proteomics investigation, are involved could help to understand the role of CTS diet and its compounds. This is the approach adopted in the next chapter which describes an untargeted metabolomics study on liver samples using the same experimental setup (as described in chapter 3).

In conclusion LPS and diet shows effects on the plasma metabolome with many metabolites involved in these changes are metabolic enzymes or amino acids whose activity is altered either by control mechanisms and/or up or down regulated synthesis. The complementary proteomics study on liver and muscle described in chapter 4 was limited in term of samples selection but nevertheless revealed interesting results which made it worthwhile to study the liver metabolome of the broilers as described in the next chapter. Further discussion that could explain the outcomes of both studies is provide in the General discussion (chapter 7).

Chapter 6 Metabolomics on liver pooled samples: effects of novel plant extracts pre and post LPS challenge

6.1 Introduction

In this chapter an untargeted metabolomics approach is used to investigate the effects of LPS and dietary supplementation on the liver metabolome. In chapter 4 our proteomics study of liver revealed that LPS challenge influences proteins associated with the APR and a number of important metabolites associated with energy metabolism. Important modulatory effects of the CTS diet were also revealed. As the liver produces most of the plasma proteins, chapter 5 (plasma metabolomics) investigated the effects of LPS and diet on the plasma metabolome. This study revealed that metabolites associated with AA metabolism and the Citrate cycle decreased in plasma following LPS challenge. However, the abundance of adenosine and a large number of unidentified metabolites in the plasma were significantly changed by the CTS diet both pre and post LPS challenge. For these reasons and in order to further investigate the mechanisms responsible for these results our attention is once again directed back to the liver in this chapter. This is the first study of its kind to look at the effects of broiler dietary supplemented with CTS extract on the liver metabolome both pre and post LPS challenge. For completeness the effect of dietary supplementation with the CMB extract were also considered.

Following the same approach used for the Metabolomics plasma investigation, a pooled sample study on liver samples was performed to investigate the role of LPS and experimental dietary treatments (CTS and CMB diets) on the broiler's liver metabolome. The results on plasma described in Chapter 5 gave confidence that the pooled approach would yield valid results.

6.2 Aims and Objective of the study

The primary aim of this study was to test the hypothesis that dietary supplementation with CTS or CMB extract can modulate the liver metabolome pre and/or post LPS challenge at T0,12,24 and 48h. To address this aim I first had to characterise how the liver metabolome in broilers receiving the CTL diet responds to LPS challenge and then compare this to that of broilers on each of the experimental diets.

6.3 Materials and methods

6.3.1 Sample selection and preparation

An untargeted metabolomics study of pooled liver samples (LC-MS based), was performed to look at the effects of LPS challenge and diets on the liver metabolome of broilers at T0h pre challenge and T12,T24,T48h post challenge at the University of Zagreb, Croatia facilities. Liver samples (N=144) from trial 2 (see chapter 3), collected from 15d old birds belonging to CTL, CTS and CMB diets at T0h pre challenge and T12,24,48h post LPS challenge were pooled together (N=48) based on the same pen, diet and time points following the same procedure applied for the plasma pooled sample study (see Figure 5.2 - chapter 5).

Samples were extracted using the optimized Polyomics protocol; 2/3 portions of liver tissue (~100 mg) were first defrosted and homogenized in 975µl of Chloroform/Methanol/Water (1:3:1) using an Omni TH220 homogenizer (Omni International, Kennesaw, USA). Samples were then vortexed for 5 min, centrifuged for 3 min at 13.000g at 4°C and ~700µl of supernatant was collected. To prepare pooled samples, 200µl of 3 individual samples, belonging to the same diet/pen and timepoint, were pooled together. Samples were then stored at -80°C until the start of the analysis.

6.3.2 Liver Untargeted Metabolomics workflow

The same Metabolomics pipeline described in the previous chapter for plasma samples (see chapter 5) was applied to liver samples. In summary, Untargeted LC-MS/MS technique, in conjunction with bioinformatics tools (PiMP and Metaboanlyst), was used to provide a complete spectrum of metabolites which were modulated by each dietary treatment (CTL, CTS and CMB) and time points pre (T0h) and post challenge (T12,24,48h). Volcano plots, Kegg maps, PCA and PLSDA were studied in detail following the same workflow applied to plasma samples.

6.4 Results

6.4.1 Pooled study on liver: LPS effect

A total of 5593 identified and annotated features were detected in the liver pooled study. Based on mass and retention time, 97 unique compounds were found to match the internal standards. In liver, significant differences were found based on LPS challenge at T0h vs post challenge time points. The 3 group-wise comparisons identified differences in fold changes (fc). Each fc was associated to significance statistics. Peaks with an adjusted $p < 0.05$ were considered significant. Identified and annotated metabolites which showed significant differences per each pairwise comparison, before and post peak and isoforms evaluation, are represented in the Table 6.1. Identified metabolites, post evaluations, are indicated in Tables 6.2, 6.3 and 6.4 (see Glasgow university repository database <http://dx.doi.org/10.5525/gla.researchdata.1272> for the full list of annotated and identified metabolites).

	BEFORE peak and isoforms evaluation		POST peak and isoforms evaluation	
Pairwise comparisons	Identified metabolites	Annotated metabolites	Identified metabolites	Annotated metabolites
CTL T0h vs CTL T12h	114	2546	35	625
CTL T0h vs CTL T24h	25	647	6	176
CTL T0h vs CTL T48h	30	688	8	156

Table 6.1 LPS challenge: pairwise comparisons of T0h vs T12,24,48h and the respective annotated and identified metabolites detected before and post peak and isoforms evaluation.

Peak id	Metabolite	Log2 fc	<i>p</i>	Adjusted <i>p</i>	Peak intensity CTL T0h	Peak intensity CTLT12h	Identification
1	Betaine	-1.04	0.0000	0.0000	2705088320	1320054272	identified+fragment
31	Hypoxanthine	-2.35	0.0000	0.0000	369858112	72556805	identified+fragment
116	L-Valine	-1.81	0.0000	0.0000	118959670	33855504	identified+fragment
137	L-Methionine	-1.88	0.0000	0.0000	88358132	24088644	identified+fragment
146	beta-Alanine	-1.55	0.0000	0.0000	109481032	37497190	identified
149	L-Arginine	-1.34	0.0000	0.0000	90412425	35638168	identified+fragment
168	Nicotinamide	-1.78	0.0000	0.0000	69032133	20070509	identified+fragment
170	L-homoserine	-1.25	0.0000	0.0000	74107600	31158635	identified+fragment
209	L-Tyrosine	-1.81	0.0000	0.0000	55242248	15791040	identified+fragment
266	L-Serine	-1.34	0.0000	0.0000	27032162	10665263	identified+fragment
411	L-Ornithine	-2.48	0.0000	0.0000	8423028	1508908	identified+fragment
448	Creatinine	-1.03	0.0000	0.0000	10594521	5180474	identified+fragment
2804	pyrophosphate	-5.25	0.0000	0.0000	9390607	246005	identified
2830	L-Aspartate	-1.27	0.0000	0.0000	73662101	30596196	identified
2838	CMP	-2.28	0.0000	0.0000	1093147	225561	identified+fragment
2993	L-isoleucine	-2.09	0.0000	0.0000	24940411	5873168	identified
3066	Orotate	-2.12	0.0000	0.0000	1025379	235142	identified
3422	L-Tryptophan	-1.54	0.0000	0.0000	3125259	1071355	identified
27	Choline phosphate	-0.91	0.0000	0.0001	405994096	215471644	identified
3801	2-Oxoglutarate	1.48	0.0000	0.0001	621631	1739905	identified

4241	cis-Aconitate	-1.53	0.0000	0.0001	228688	79253	identified
225	L-Lysine	-1.42	0.0000	0.0002	43407129	16207801	identified+fragment
1114	riboflavin	-1.25	0.0000	0.0002	1078849	454554	identified+fragment
693	Cytidine	-1.32	0.0000	0.0003	3255725	1304475	identified
60	L-Kynurenine	-1.34	0.0001	0.0005	2848111	1127072	identified+fragment
2801	Taurine	-0.67	0.0002	0.0008	104988204	65820270	identified+fragment
1780	L-Cystine	-3.25	0.0005	0.0019	301284	31620	identified
4033	D-Glucosamine	-0.94	0.0005	0.0019	137594	71710	identified
277	Adenine	-0.65	0.0019	0.0058	32470894	20649249	identified+fragment
128	L-Glutamate	-0.51	0.0028	0.0079	99882658	69948984	identified+fragment

Table 6.2 Significant metabolites in CTL vs CTL diet in liver samples at T12h

List of first 30 significant identified metabolites ($p < 0.05$) with the relative Log₂ fc, p , adjusted p and identification. Metabolites listed in the order of increasing adjusted p .

Peak id	Metabolite	Log2 fc	<i>p</i>	Adjusted <i>p</i>	Peak intensity CTL T0h	Peak intensity CTLT24h	Identification
146	beta-Alanine	-0.88	0.0000	0.0006	109481032	59616172	identified
2830	L-Aspartate	-1.06	0.0001	0.0027	73662101	35427470	identified
1114	riboflavin	-1.12	0.0003	0.0076	1078849	495926	identified+fragment
2804	pyrophosphate	-2.73	0.0004	0.0087	9390607	1418222	identified
209	L-Tyrosine	-0.83	0.0006	0.0111	55242248	30981864	identified+fragment
411	L-Ornithine	-1.08	0.0058	0.0486	8423028	3979480	identified+fragment

Table 6.3 Significant metabolites in CTL vs CTL diet in liver samples at T24h

List of significant identified metabolites ($p < 0.05$) with the relative Log fc, *p*, adjusted *p* and identification. Metabolites listed in the order of increasing adjusted *p*.

Peak id	Metabolite	Log2 fc	<i>p</i>	Adjusted <i>p</i>	Peak intensity CTL T0h	Peak intensity CTLT48h	Identification
2830	L-Aspartate	-1.11	0.0000	0.0010	73662101	34116336	identified
303	AMP	1.27	0.0000	0.0011	12457422	30086573	identified+fragment
46	Adenosine	1.13	0.0006	0.0134	113782140	249397612	identified+fragment
411	L-Ornithine	-1.38	0.0008	0.0123	8423028	3242198	identified+fragment
1780	L-Cystine	-1.65	0.0013	0.0172	301284	95803	identified
209	L-Tyrosine	-0.72	0.0037	0.0346	55242248	33484049	identified+fragment
2838	CMP	-1.28	0.0051	0.0428	1093147	448889	identified+fragment
137	L-Methionine	-0.82	0.0057	0.0461	88358132	49906705	identified+fragment

Table 6.4 Significant metabolites in CTL vs CTL diet in liver samples at T48h

List of significant identified metabolites ($p < 0.05$) with the relative Log2 fc, *p*, adjusted *p* and identification. Metabolites listed in the order of increasing adjusted *p*.

Metabolic pathways were used to study the relation among these identified and annotated metabolites (before and after data normalization) to find out the ones which were mainly influenced by LPS during the first T12h post challenge. Alanine, Aspartate, Glutamate/ Glycine, Serine, Threonine/ Methionine and Cysteine/ Arginine and Proline, Krebs cycle, Glycolysis/Gluconeogenesis, purine, and pyrimidine pathways, showed a significant decrease of their intermediates. In each pathway, identified (yellow dot), annotated (grey dot) and unknown (white dot) metabolites are represented. Metabolites circled in red and green represent respectively the ones which were confirmed to be significantly decreased and increased by LPS challenge at T12h (Figure 6.1A, B, C, D, E).

- In **alanine, Aspartate and Glutamate** pathway: L-Alanine, L-Aspartate, L-Asparagine, Succinate, 2-Oxoglutarate, L-1-Pyroline -5-carboxylate were confirmed to be significantly decreased by LPS at T12h post challenge while the abundance of 2-Oxoglutarate was found increased by LPS (Figure 6.1A).
- In **Glycine, Serine and Threonine** pathway: 2-Phospho-D-glycerate, 3P-D-Glycerate, Serine, L-Tryptophane, L-Cysteine, Guanidinoacetate, Betaine, Sarcosine, 5-Aminolevulinate, Threonine, Homoserine, L-Aspartate, L-Aspartate 4-semialdehyde, L-Ectoine were found to be decreased by LPS in the first T12h post challenge (Figure 6.1B).
- In **Cysteine and Methionine** pathway: L-Serine, 2-Aminocysteate, O-Acetyl-L-Serine, Sulfate, L-Cystine, 3-Sulfo-pyruvate, L-Alanine, D-Cysteine, L-Cysteine-sulfinate, L-Aspartate, L-Homoserine, L-Cystathionine, L-Homocysteine, L-Methionine-S-oxide, L-Methionine, S-Adenyl-L-homocysteine, 5-Methyl-5-thioadenosine, Ethylene were found significantly decreased by LPS at T12h post challenge. The only metabolite found to increase was N-Formyl-L-methionine (Figure 6.1C).
- In **Arginine and Proline** pathway: N2-Succinyl-L-arginine, Octopine, Arginine, Sarcosine, Ornithine, Creatinine, Proline, D-Proline, 1-Pyroline-2-carboxylate, 5-aminopentanoate, Glyoxylate, 2-Oxoarginine, 4-Guanidino-butanoate, N-4-Acetyl-aminobutanal, N-4-Acetyl-amino-butanoate, 4-Amino-butanoate were found decreased by LPS at T12h post challenge. N2-Succinyl-L-ornithine displayed an increase in its abundance at T12h post LPS challenge (Figure 6.1D).
- **Glycolysis and Gluconeogenesis** pathway: α -D-Glucose, β -D-Glucose, α -D-Glucose-1P, α -D-Glucose-6P, β -D-Fructose-6P, β -D-Fructose-1,6P2,

Glyceraldehyde-3P, Glycerate-3P, Glycerate-2P were significantly decreased by LPS at T12h (Figure 6.1E).

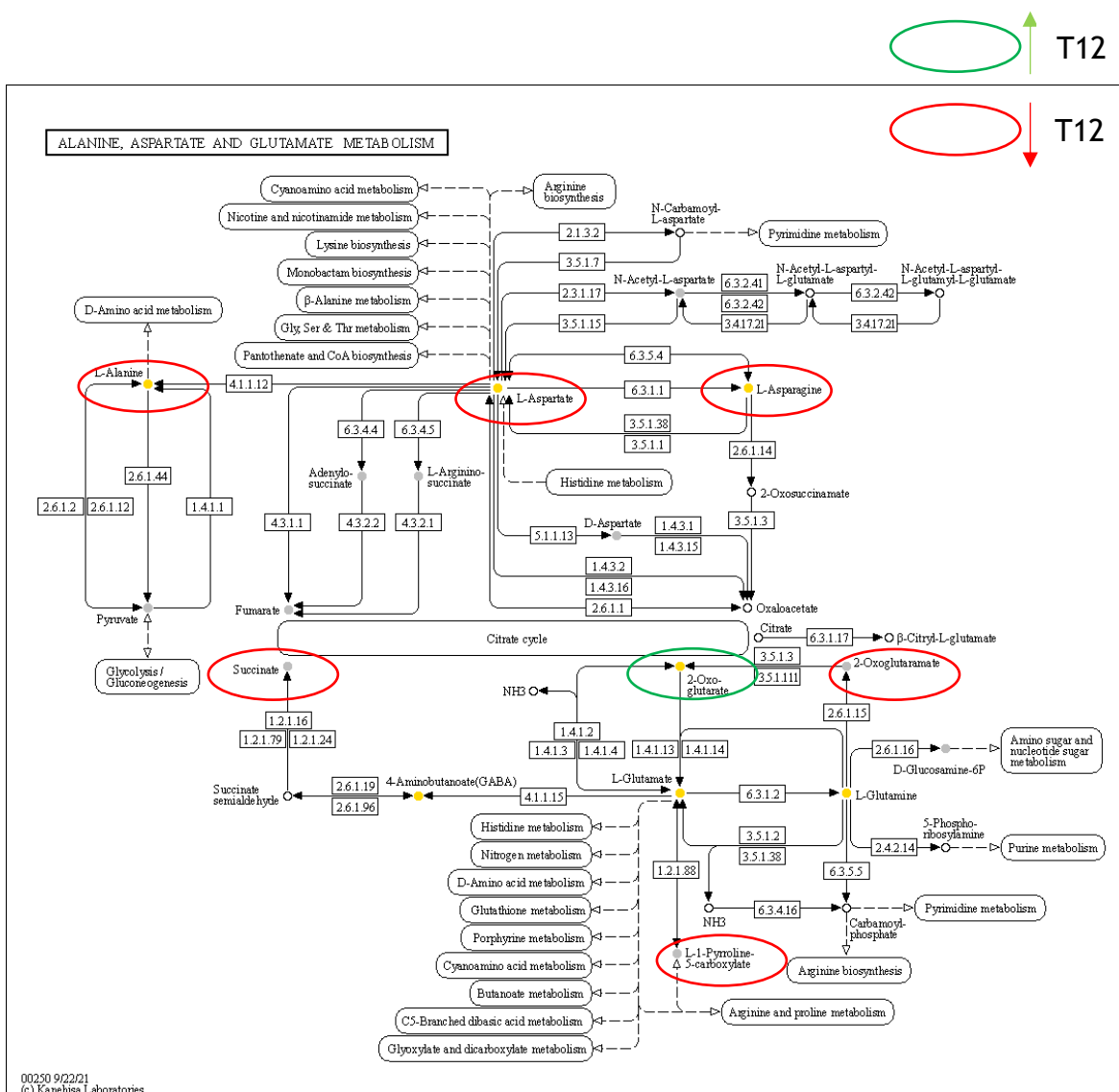

A

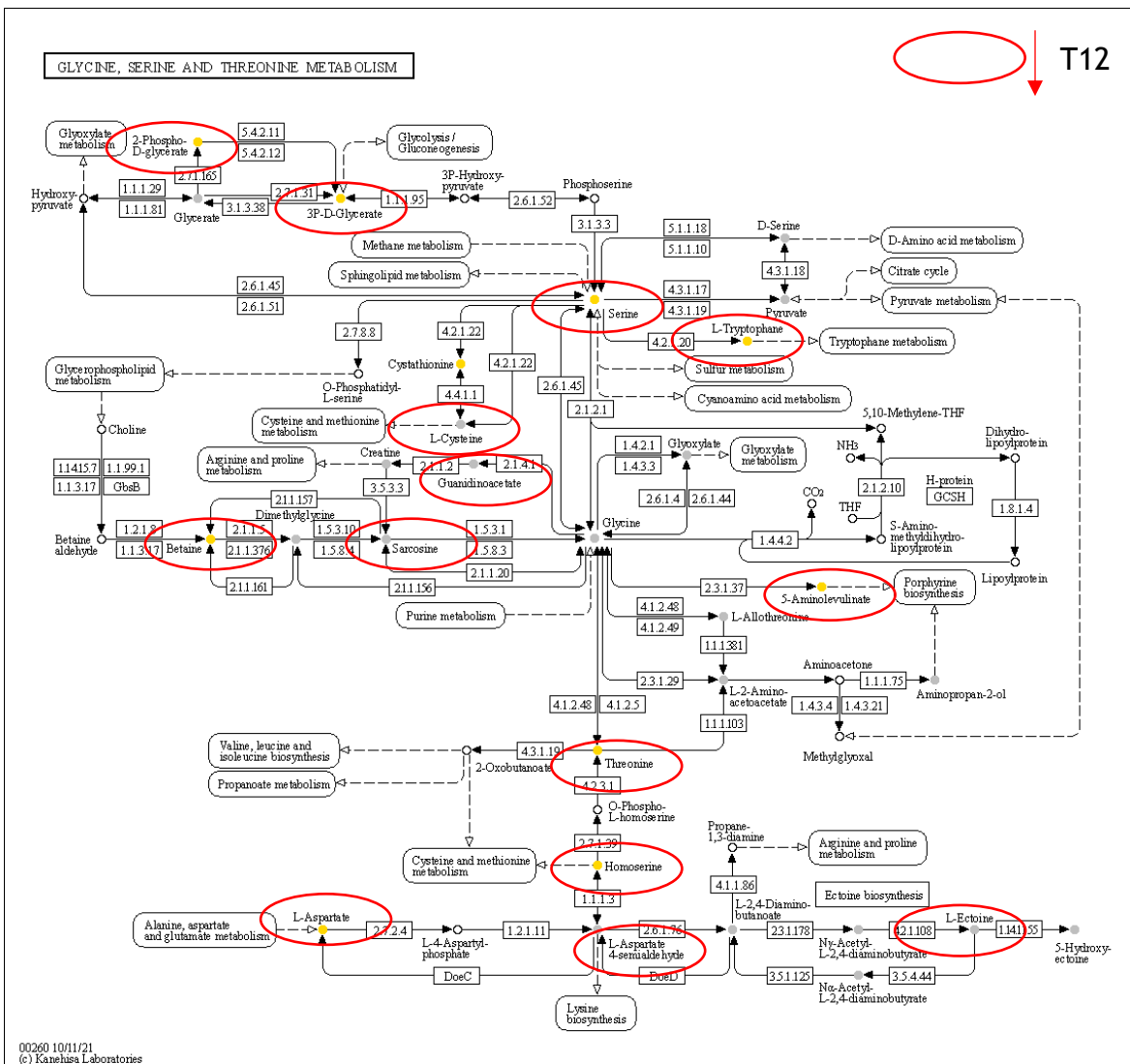

B

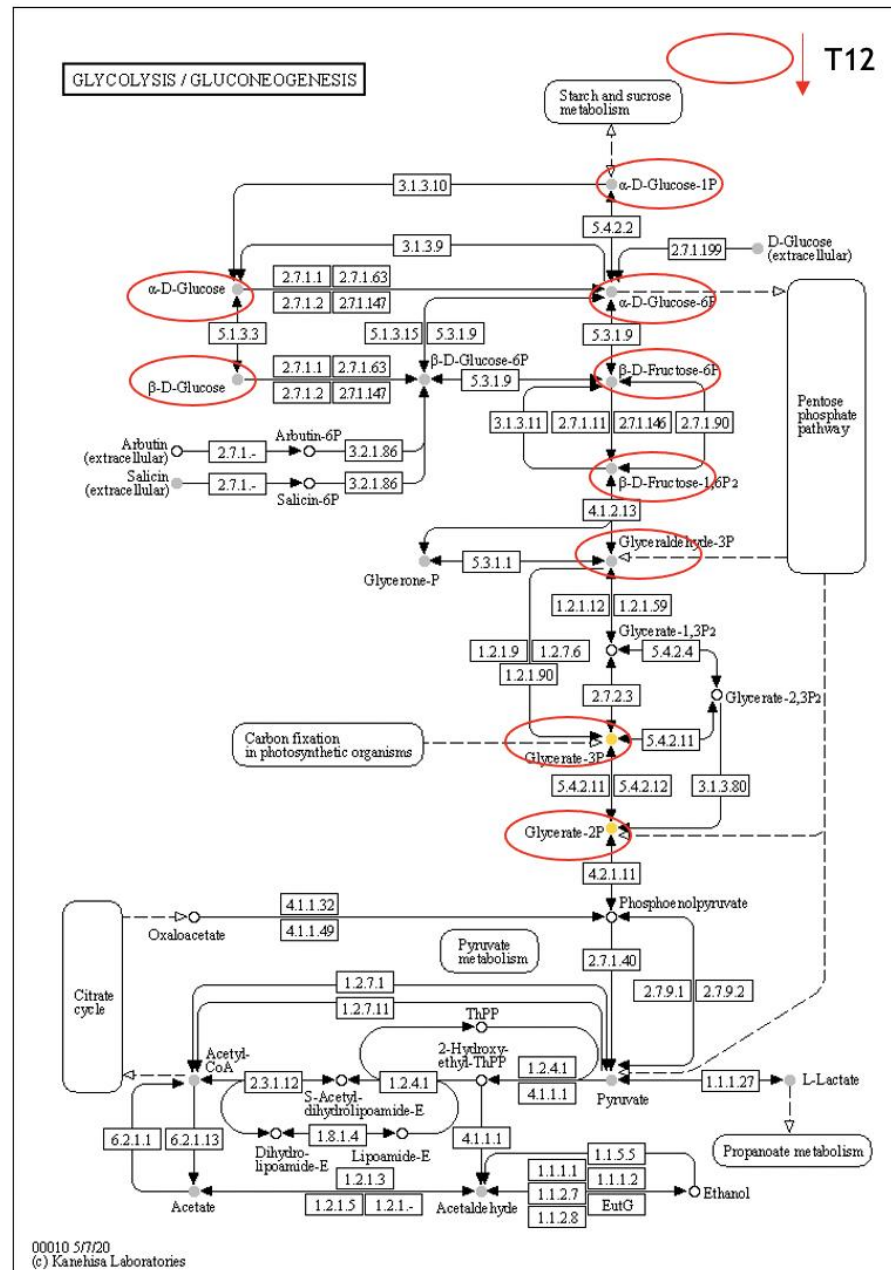

E

Figure 6.1 KEGG pathways influenced by LPS challenge at T12h compared to pre challenge at T0h

Alanine, Aspartate and Glutamate pathway (Figure A), Glycine, Serine and Threonine pathway (Figure B), Cysteine and Methionine pathway (Figure C), Arginine and Proline pathway (Figure D), Glycolysis/Gluconeogenesis (Figure E) are displayed. In all pathways, green cycle indicates intermediates significantly increased by LPS at T12h while the red cycle represents the ones significantly decreased at the same time point compared to T0h pre challenge. Yellow dots indicate identified metabolites while grey dots indicate annotated metabolites and white dots the unknown metabolites.

Following data normalization in MetaboAnalyst, multivariate analysis was applied; PCA and PLSDA shown in Figure 6.2 confirmed LPS can significantly modulate the entire liver metabolome of broilers, compared to T0h pre challenge, mainly at T12h and T48h in PCA plot and T24h and T48h post challenge in PLSDA.

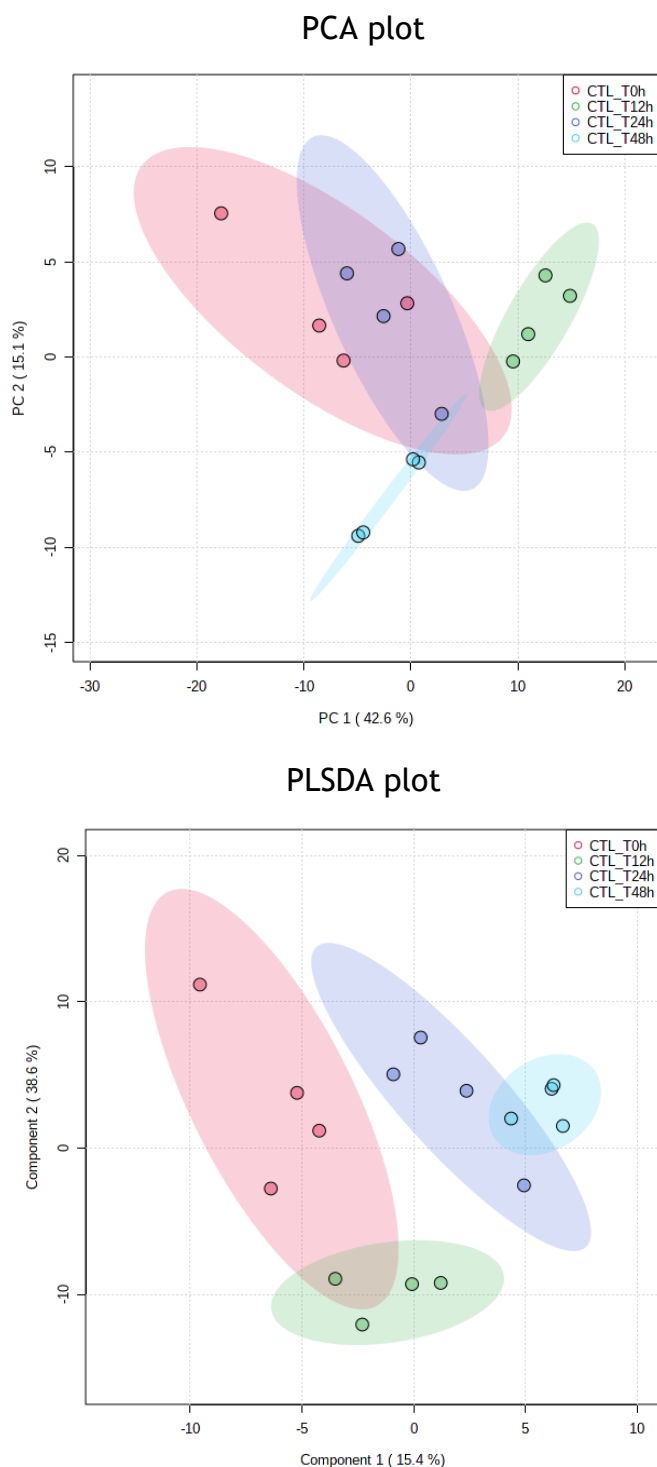

Figure 6.2 PCA and PLSDA of samples belonged to CTL diets at time points 0,12,24 and 48h pre and post challenge.

In PCA, samples clustered depending on LPS mainly at T12 and T48h post challenge. Minor differences are observed between T0h and T24h). In PLSDA, all time points clustered separately. In both multivariate analyses, LPS shifted the overall metabolome composition post challenge.

Metabolites which were considered more interesting, in terms of their biological role and the pathway in which they are involved, were studied in detail. For example, essential amino acids such as Cysteine, Methionine, Arginine, Proline (+ ion mode) were studied pre and post challenge at all time points. The decrease in metabolites abundance caused by LPS at T12h was confirmed in all diets (see Figure 6.3).

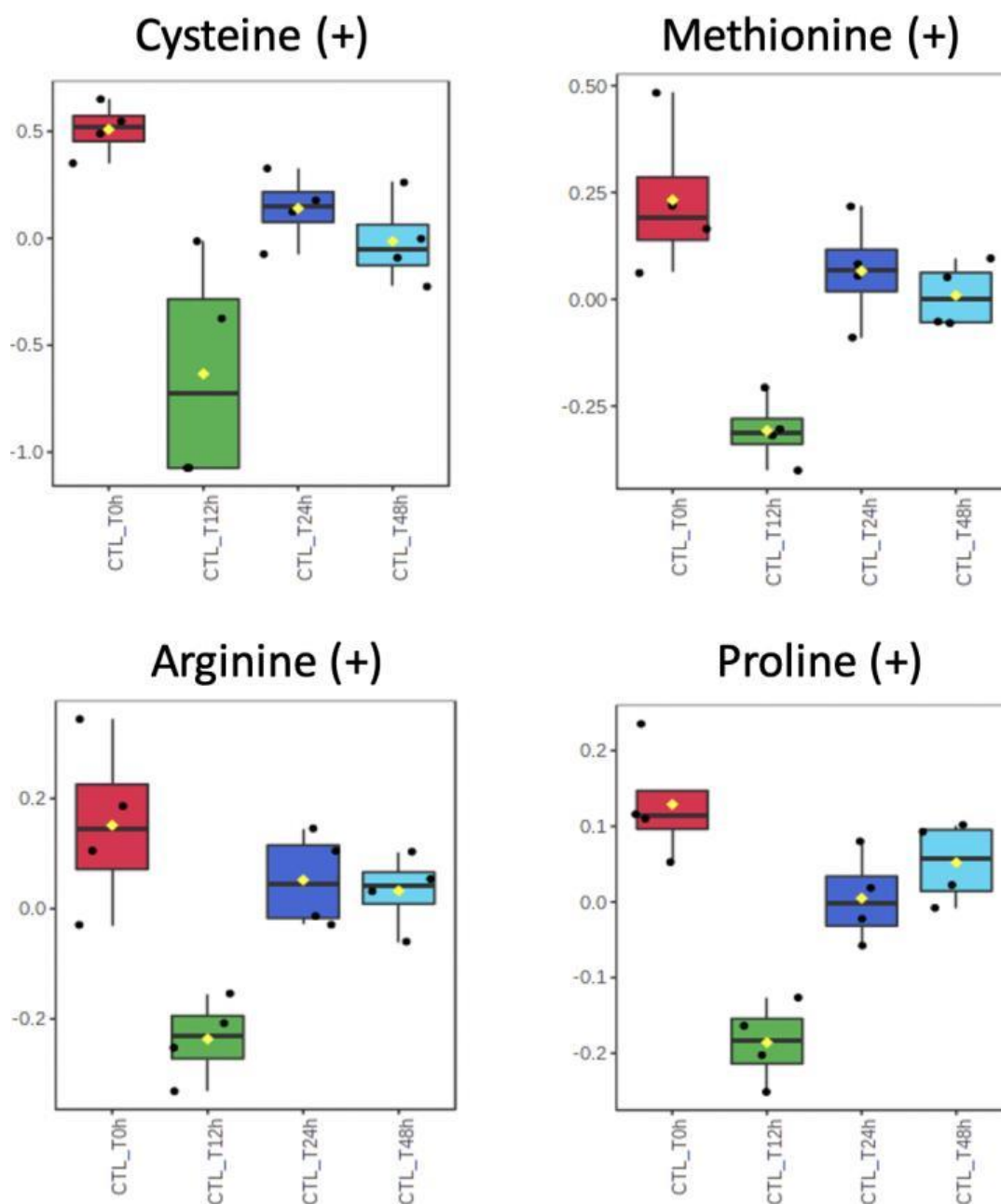

Figure 6.3 Cysteine, Methionine, Arginine and Proline, pre (T0h) and post (T12,24,48h) LPS challenge in CTL diet

The box and whisker plots (mean \pm SD) referring to CTL diet at each timepoint summarize the normalized values of Cysteine, Methionine, Arginine and Proline intensity. All metabolites resulted to be significantly decreased at T12h compared to T0,24,48h ($p < 0.05$). These metabolites are shown in the positive ion mode (+).

6.4.2 Pooled study on liver: dietary effect

Significant differences (adjusted $p < 0.05$) were found based on experimental diets. CMB diet was found to slightly affect the broilers metabolome at T12h post challenge. However, our attention was focused on CTS diet which showed a strong effect at most of the time points pre and post challenge. The 4 group-wise comparisons (CTL vs CTS diet) identified significant changes mainly associated to the early phase of LPS injection (T12h post challenge); peaks with an adjusted $p < 0.05$ were considered significant. The overall list of annotated and identified metabolites was studied and filtered based on peak and isoform's evaluation (Table 6.5). The first 30 identified metabolites modulated by LPS challenge at T12h can be seen in the Table 6.5; the higher significance was found associated to amino acids metabolism. The full list of identified and annotated metabolites significantly different at each time point based on dietary treatments can be consulted at the Glasgow university repository database (<https://researchdata.gla.ac.uk>).

Pairwise comparisons	BEFORE peak and isoforms evaluation		POST peak and isoforms evaluation	
	Identified metabolites	Annotated metabolites	Identified metabolites	Annotated metabolites
CTL T0h vs CTS T0h	2	98	2	23
CTL T12h vs CTS T12h	146	3146	49	800
CTL T24h vs CTS T24h	0	79	0	20
CTL T48h vs CTS T48h	0	66	0	15

Table 6.5 Pairwise comparisons of CTL vs CTS diet at each time point (T0,12,24,48h) and the respective annotated and identified metabolites detected before and post peak and isoforms evaluation.

Peak id	Metabolite	Log2 FC	<i>p</i>	Adjusted <i>p</i>	Peak intensity CTL T12h	Peak intensity CTS T12h	Identification
1	Betaine	0.97	0.0000	0.0000	1366206763	2670571008	identified+fragment
27	Choline phosphate	1.15	0.0000	0.0000	198816456	442474952	identified
31	Hypoxanthine	2.52	0.0000	0.0000	56656878	326040096	identified+fragment
60	L-Kynurenine	-1.62	0.0000	0.0000	17241694	5625174	identified+fragment
101	FMN	1.41	0.0000	0.0000	119897	318297	identified
116	L-Valine	1.62	0.0000	0.0000	50048747	153379136	identified+fragment
128	L-Glutamate	1.27	0.0000	0.0000	61795585	148549786	identified+fragment
133	L-Citrulline	2.62	0.0000	0.0000	15388150	94526498	identified+fragment
137	L-Methionine	2.64	0.0000	0.0000	18339888	114298440	identified+fragment
146	beta-Alanine	1.82	0.0000	0.0000	26959159	94882372	identified
149	L-Arginine	1.48	0.0000	0.0000	37983687	105946074	identified+fragment
168	Nicotinamide	1.66	0.0000	0.0000	29173622	92235718	identified+fragment
170	L-homoserine	1.94	0.0000	0.0000	24503412	94174260	identified+fragment
209	L-Tyrosine	2.33	0.0000	0.0000	13316641	66731657	identified+fragment
225	L-Lysine	2.05	0.0000	0.0000	16418266	67950599	identified+fragment
266	L-Serine	2.52	0.0000	0.0000	7370024	42195865	identified+fragment

277	Adenine	1.33	0.0000	0.0000	16202056	40709146	identified+fragment
303	AMP	-1.09	0.0000	0.0000	13999092	6588582	identified+fragment
411	L-Ornithine	2.48	0.0000	0.0000	2133712	11908962	identified+fragment
448	Creatinine	1.42	0.0000	0.0000	4555200	12222408	identified+fragment
693	Cytidine	1.77	0.0000	0.0000	1622648	5543777	identified
1114	riboflavin	2.04	0.0000	0.0000	393112	1611531	identified+fragment
2801	Taurine	1.40	0.0000	0.0000	48784079	128870158	identified+fragment
2804	pyrophosphate	-0.20	0.0000	0.0000	17188574	14973340	identified
2838	CMP	1.79	0.0000	0.0000	270903	938746	identified+fragment
2867	sn-Glycerol 3-phosphate	1.34	0.0000	0.0000	35165264	88759352	identified+fragment
2993	L-isoleucine	3.10	0.0000	0.0000	4029403	34608311	identified
3066	Orotate	2.17	0.0000	0.0000	215523	970790	identified
3422	L-Tryptophan	1.80	0.0000	0.0000	1096132	3826471	identified
3801	2-Oxoglutarate	-1.25	0.0000	0.0000	1451488	611201	identified

Table 6.6 Significant metabolites in CTL T12h vs CTS T12h in liver samples

List of the first 30 significant identified metabolites ($p < 0.05$) with the relative Log₂ fc, p , adjusted p and identification. Metabolites listed in the order of increasing adjusted p .

Due to the massive modulation observed by CTS diet at T12h post challenge, the relation among metabolites at T12h was studied through the KEGG maps. Five metabolic pathways (Figure 6.4): Alanine, Aspartate, Glutamate/ Glycine, Serine, Threonine/ Methionine and Cysteine/ Arginine and Proline/ Citrate cycle/Glycolysis and Gluconeogenesis were confirmed to be influenced by CTS diet. In each pathway, both identified (yellow dots) and annotated (grey dots) metabolites were studied: most of intermediates in each pathway showed a significant increase in their abundance at T12h post challenge when CTS diet is supplied in broilers diet (green circle in Figures 6.2).

- **In alanine, Aspartate and Glutamate pathway:** N-Acetyl-L-aspartate, L-Alanine, L-Aspartate, L-Asparagine, D-Aspartate, L-Glutamine, L-Glutamate, Adenylo-succinate, L-Arginino-succinate, Pyruvate, 2-Oxoglutarate, 4-Aminobutanoate, L-1-Pyrroline-5-carboxylate were confirmed to be significantly increased by CTS diet at T12h post challenge while 2-Oxoglutarate was found to be decreased by CTS diet (Figure 6.4A).
- **In Glycine, Serine and Threonine pathway:** 2-Phospho-D-glycerate, 3P-D-Glycerate, Serine, D-Serine, Pyruvate, L-Tryptophane, Cystathionine, Creatine, Glycine, L-Allothreonine, L-2-Amino-acetoacetate, Aminopropen-2-ol, L-Cysteine, Betaine, Sarcosine, 5-Aminolevulinate, Threonine, Homoserine, L-Aspartate, L-Aspartate were found to be increased by CTS diet in the first T12h post challenge (Figure 6.4B).
- **In Cysteine and Methionine pathway:** L-Serine, O-Acetyl-L-Serine, Sulfate, L-Cystine, Pyruvate, 3-Sulfo-pyruvate, L-Alanine, D-Cysteine, L-Cysteine-sulfinate, L-Aspartate, L-Homoserine, L-Cystathionine, L-Homocysteine, L-Methionine-S-oxide, L-Methionine, S-Adenyl-L-homoadenosine, S-Adenyl-L-homocysteine, 5-Methyl-5-thio-D-ribose, Methanethiol were found significantly increased by CTS diet at T12h post challenge (Figure 6.4C).
- **In Arginine and Proline pathway:** Glutamate, Guanidino-acetate, Sarcosine, Octopine, Arginine, Sarcosine, Ornithine, Creatinine, L-Glutamate-5-semialdehyde, 1-Pyrroline-5-carboxylate, Proline, D-Proline, 4-Hydroxyproline, Pyruvate, Glyoxylate, 5-Aminopentanoate, 1-Pyrroline-2-carboxylate, 1-Pyrroline-5-carboxylate, 2-Oxo-5-aminovalenate, N-Hydroxy-arginine, 2-Oxoarginine, Feruloyl-putrescine, N-Acetyl-putrescine, N-4-Acetyl-aminobutanal, N-4-Acetyl-amino-butanoate, 4-Amino-butanoate, L-Aspartate-4-semialdehyde, γ -L-Glutamylputrescine were found increased by CTS diet at T12h post challenge

(Figure 6.4D). 4-Guanidino-butanoate displayed a decrease in its abundance at T12h in broilers fed with CTS diet.

- **Citrate cycle pathway:** Citrate, Isocitrate, Pyruvate were found significantly higher at T12h in CTS diet while Acetyl-CoA, (S)-Malate and 2-Oxoglutarate showed a significant decrease in their abundances (Figure 6.4E).
- **Glycolysis/Gluconeogenesis pathway:** α -D-Glucose, β -D-Glucose, β -D-Glucose-6P, β -D-Fructose-6P α -D-Glucose-1P, α -D-Glucose-6P, β -D-Fructose-1,6P2, Glyceraldehyde-3P, Glycerate-3P, Glycerate-2P, Pyruvate were significantly increased by CTS diet at T12h (Figure 6.4F).

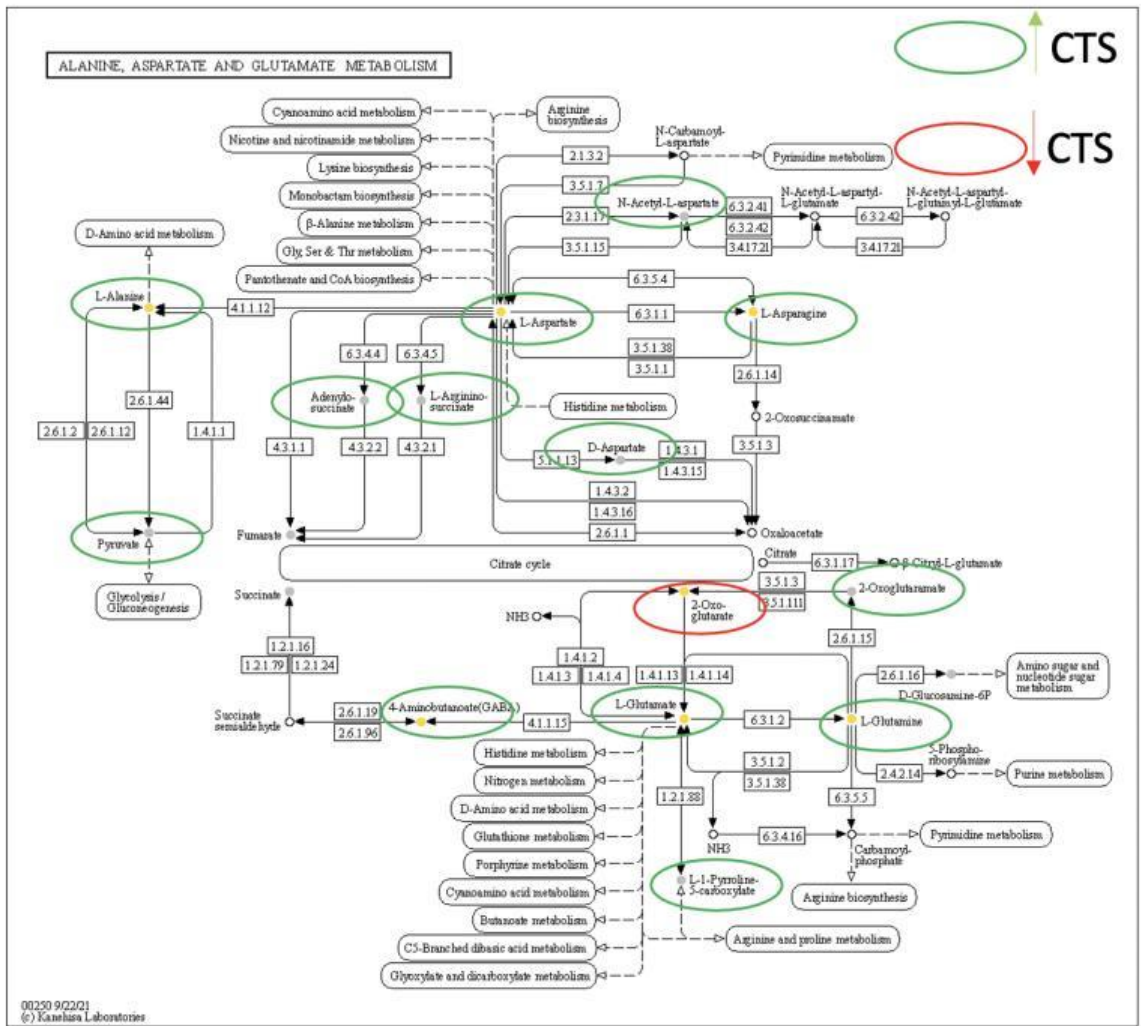

A

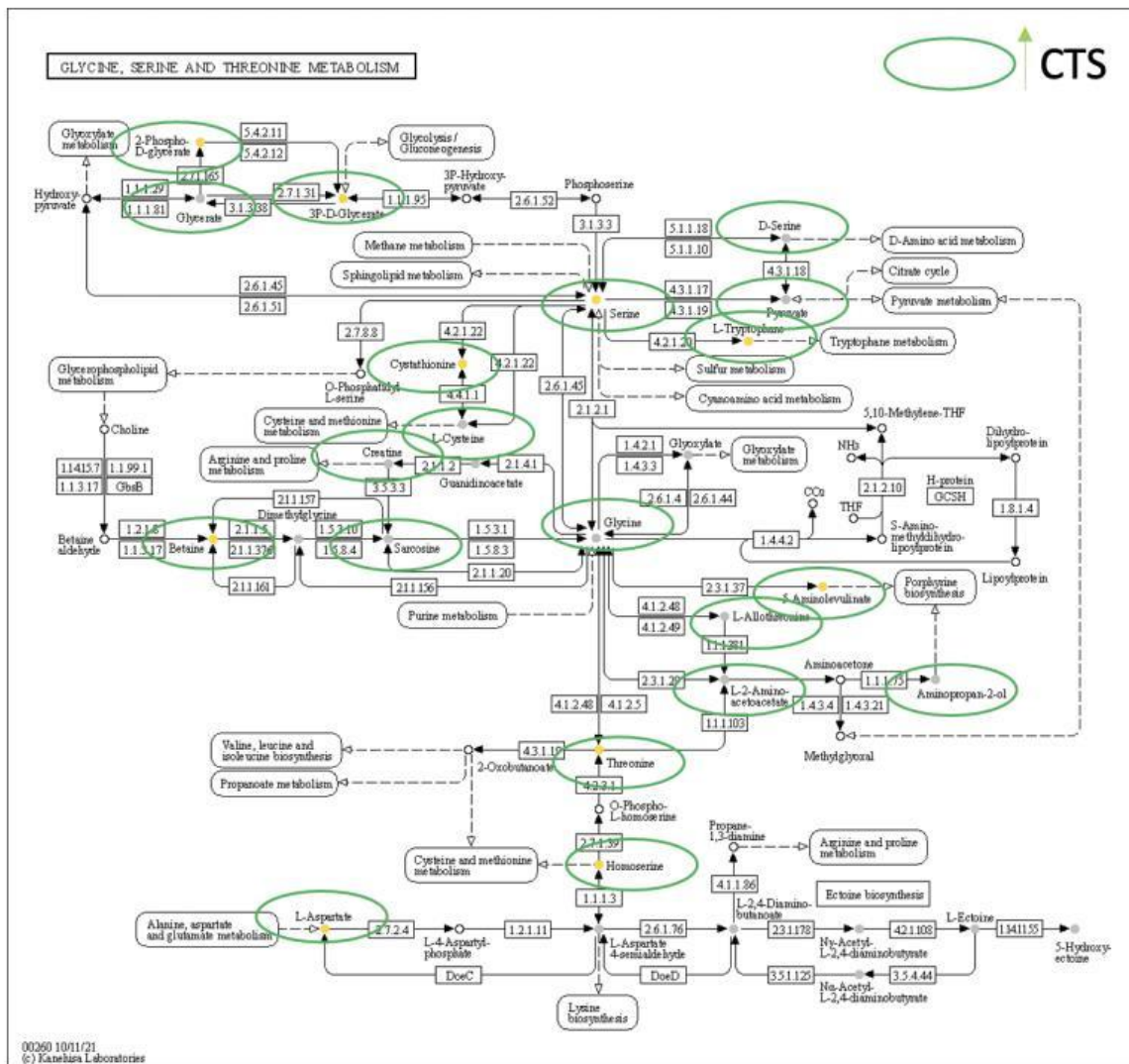

B

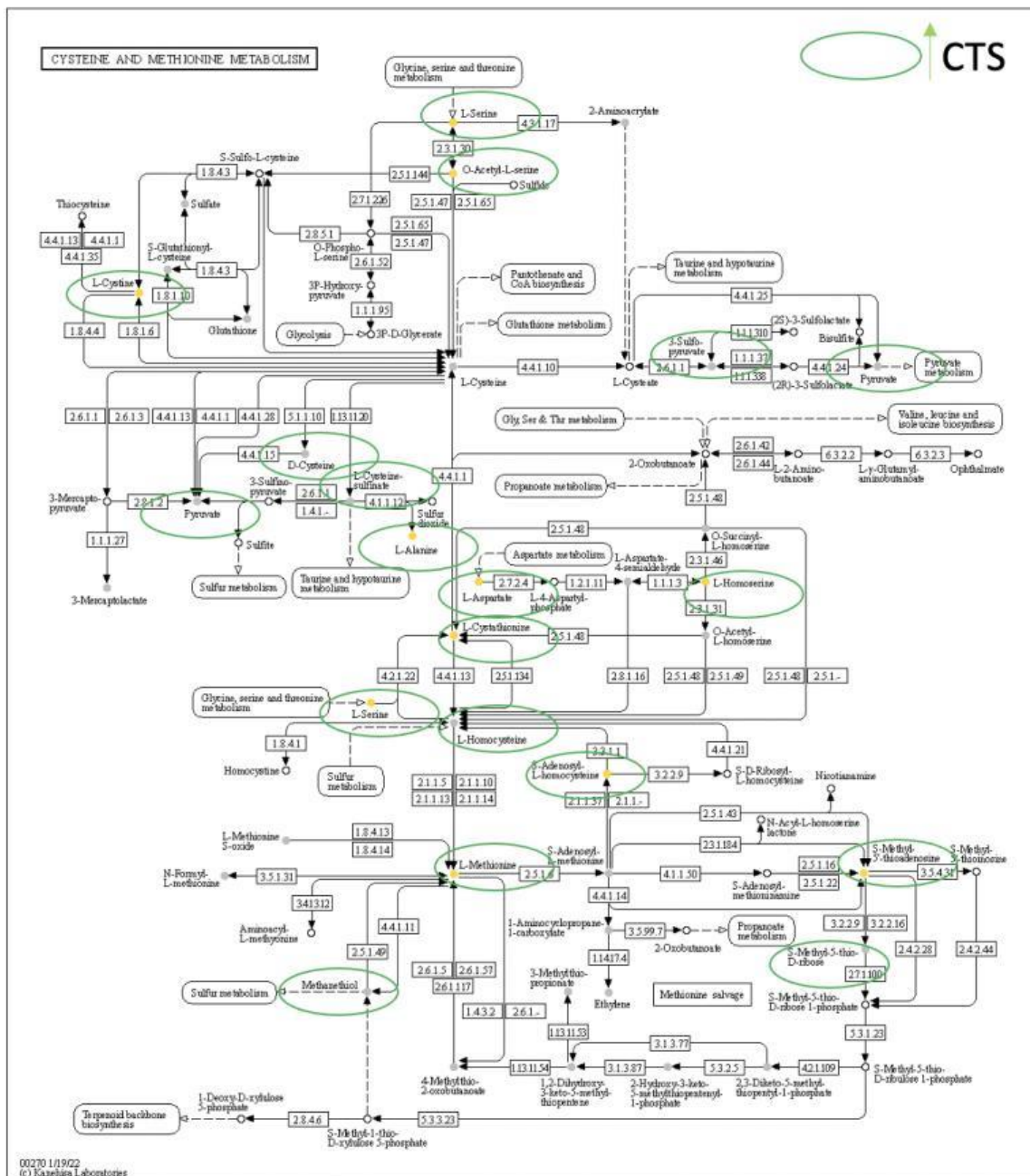

C

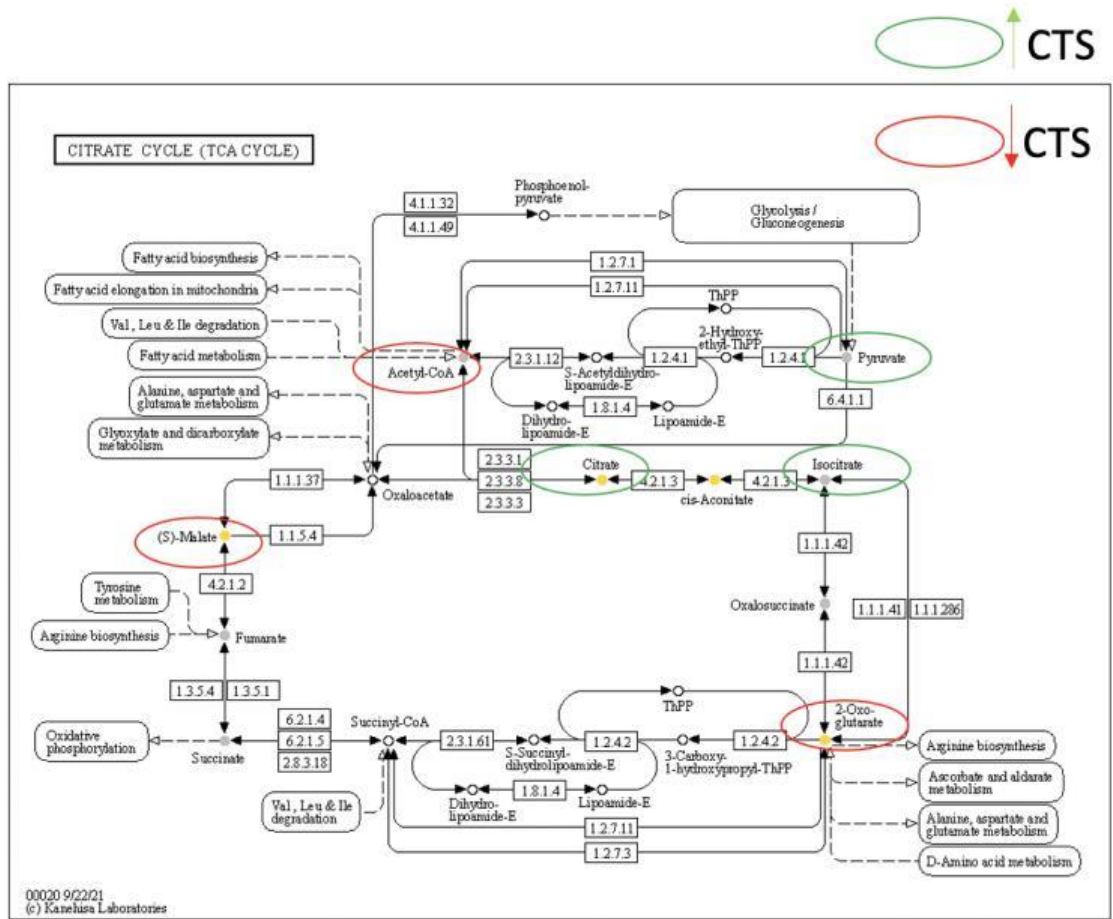

E

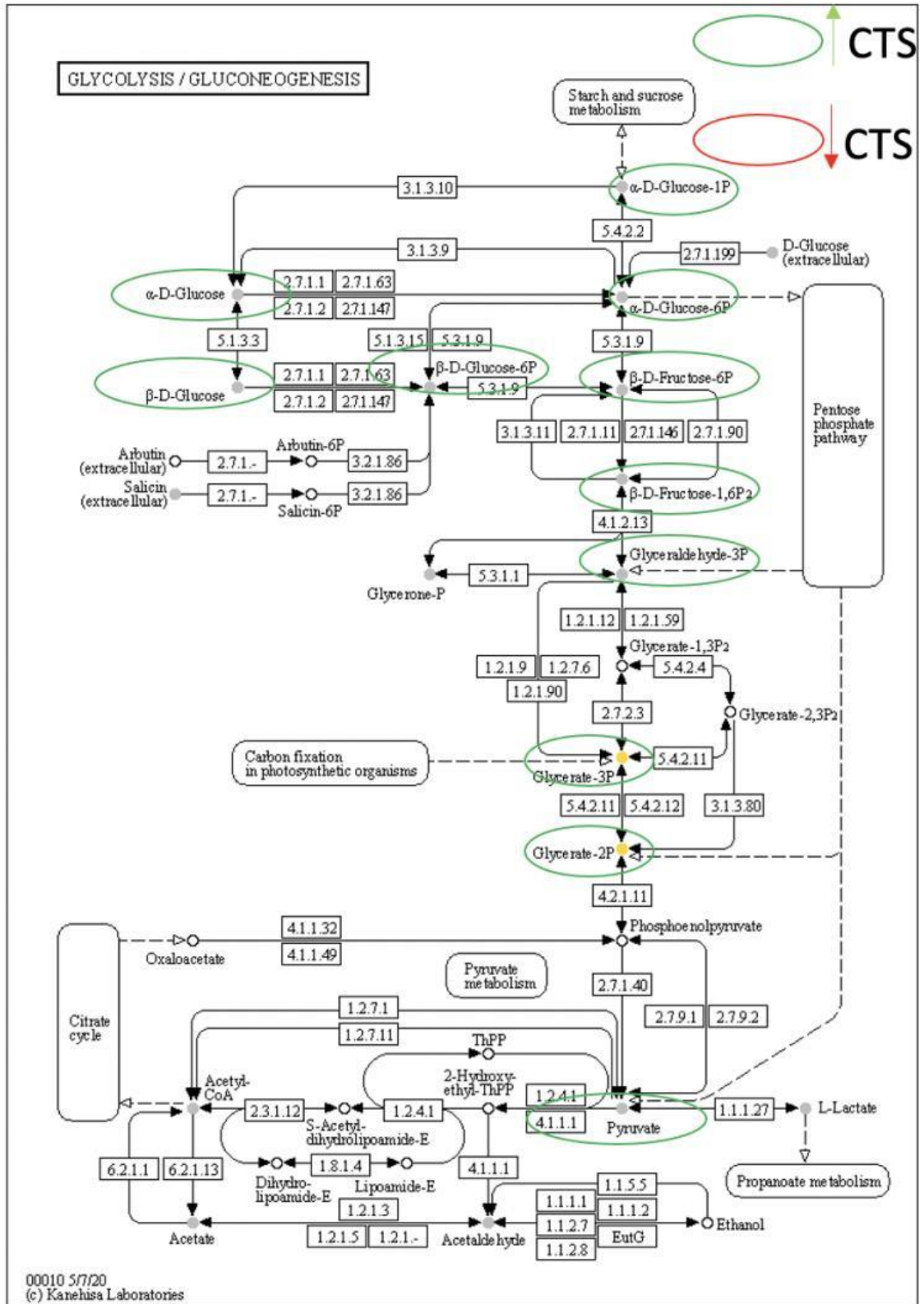

F

Figure 6.4 KEGG pathways influenced by CTS diet at 12h post challenge

Alanine, Aspartate and Glutamate pathway (Figure A), Glycine, Serine and Threonine pathway (Figure B), Cysteine and Methionine pathway (Figure C), Arginine and Proline pathway (Figure D), Citrate cycle (Figure E) and Glycolysis/Gluconeogenesis (Figure F) are displayed. In all pathways, green circle indicates intermediates significantly increased by CTS while the red circle represents the ones significantly decreased. Yellow dots indicate identified metabolites while grey dots indicate annotated metabolites and white dots the unknown metabolites.

Multivariate analysis, PCA and PLSDA (Figure 6.5), was also investigated in MetaboAnalyst. In PCA and PLSDA plots, samples clearly clustered separately based on CTS diet vs CTL diet at T12h. Less differences were observed at T0h, T24h, and T48h comparing CTS vs CTL diet.

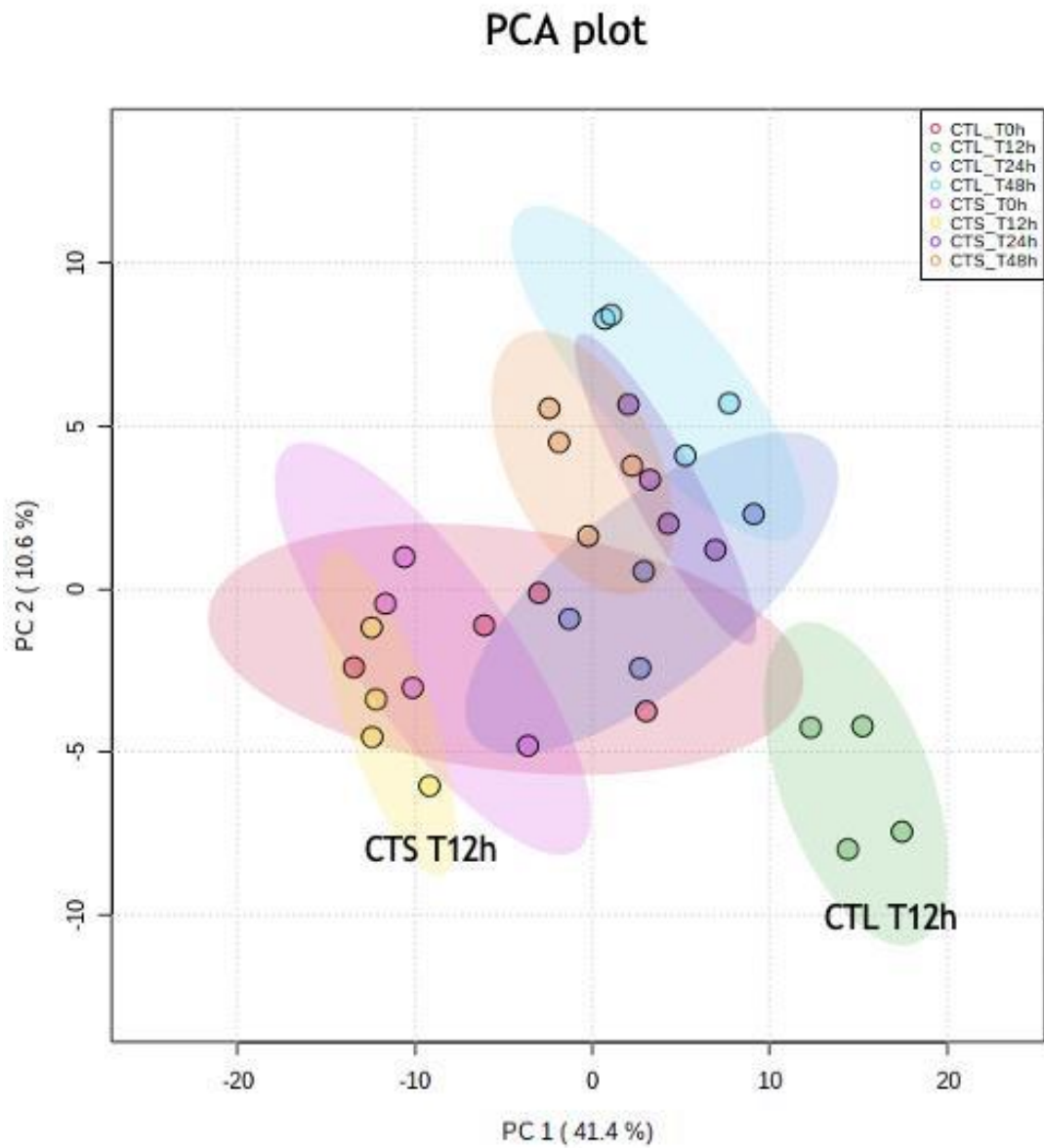

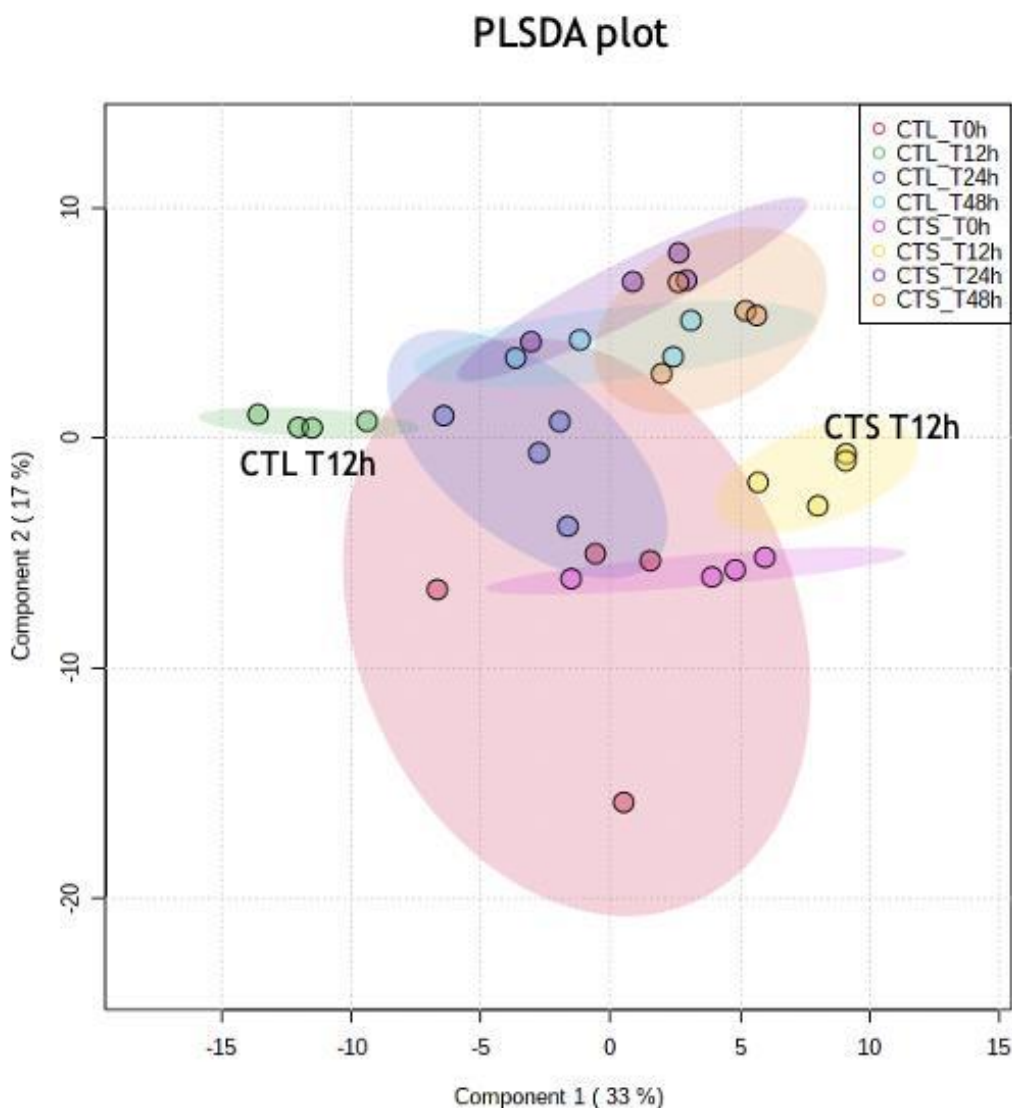

Figure 6.5 PCA and PLSDA of samples belonged to CTS and CTL diets at T0, T12, T24, T48h pre and post challenge.

In both PCA and PLSDA, samples clustered depending on CTS diet mainly at T12h post challenge. No overall metabolome modulation is observed based on LPS challenge itself comparing the different time points.

Many metabolites, influenced by CTS diet, were studied in detail during the overall LPS response from T0h pre challenge to T48h post challenge. An example is reported in the Figure 6.6 below which showed essential amino acids such as Cysteine, Methionine, Arginine and Proline and intermediates of the Citrate cycle such as Citrate. The abundance of these metabolites resulted to be significantly higher in CTS diet compared to CTL diet at 12 hours post challenge while less differences were found at T24h and T48h. Metabolites levels in CTL diet significantly decrease at T12h post challenge while in CTS diet no significant differences were found by comparing T0h vs T12h.

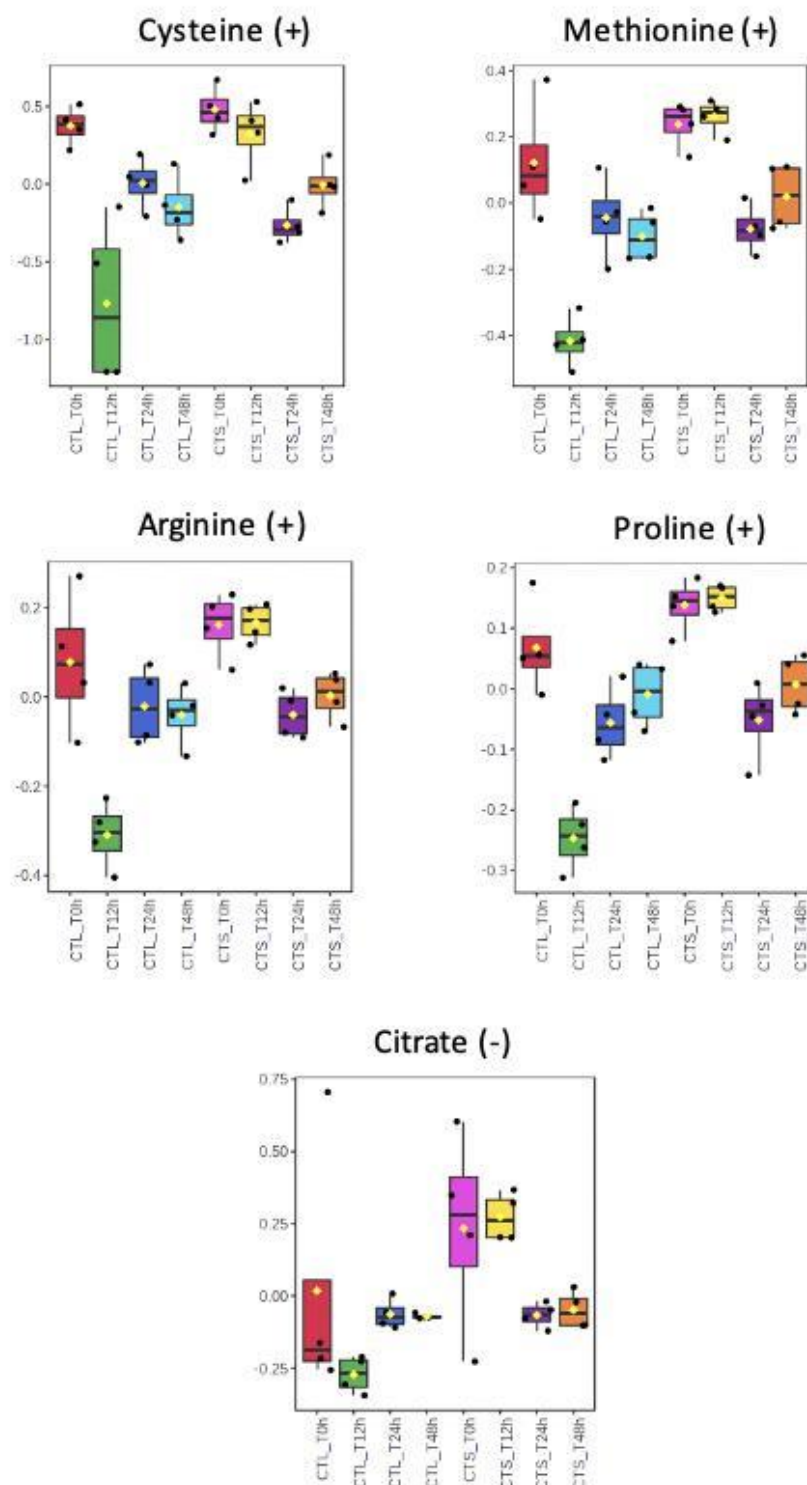

Figure 6.6 Cysteine, Methionine, Arginine, Proline and Citrate pre (T0h) and post (T12,24,48h) LPS challenge

The box and whisker plots (mean \pm SD) referring to CTL and CTS diet at each timepoint summarize the normalized values of Cysteine, Methionine, Arginine, Proline and Citrate intensities. All these metabolites showed higher abundance in CTS diet at T12h compared to CTL diet at the same time point, while less differences were found at T24h and T48h ($p < 0.05$). These metabolites are shown in the positive ion mode (+).

Adenosine was also studied in detail at each time point as it was the major identified metabolite in plasma modulated by CTS diet (see 5.4.3 Plasma metabolome: dietary effects). Its abundance resulted significantly lower at T0h pre challenge and T12h post challenge in CTS diet compared to CTL, while a significant higher abundance was discovered at T48h in CTL diet compared to CTS diet (Figure 6.7).

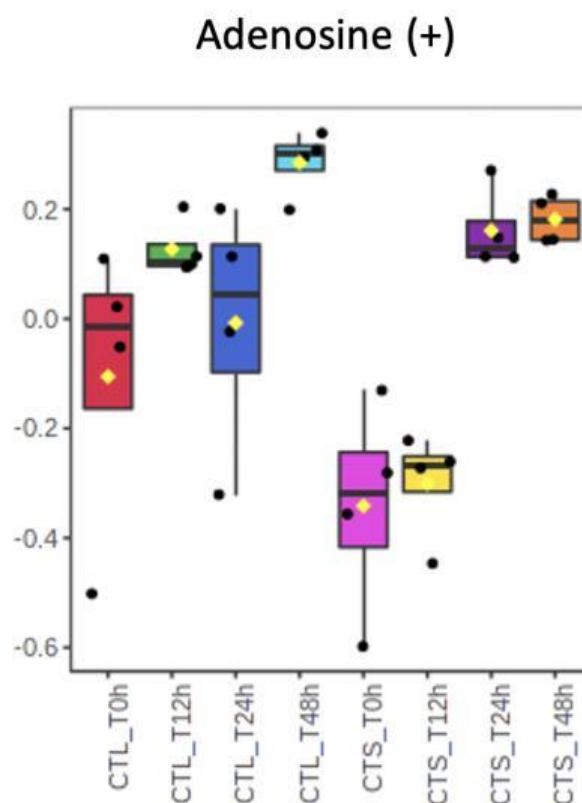

Figure 6.7 Adenosine intensity of samples at T0,12,24,48 in CTS and CTL diets.

The box and whisker plots (mean \pm SD) referring to CTL and CTS diets at each timepoint summarize the normalized values of Adenosine. The intensity of Adenosine is significantly lower at T0h and T12h in broilers fed with CTS diet compared to CTL while at T48h birds on the CTL diet displayed a significantly higher abundance compared to CTS at the same time points ($p < 0.05$). This metabolite is shown in the positive ion mode (+).

6.5 Discussion

In this chapter the effects of LPS and dietary treatments (CTS and CMB diets) were explored on the liver metabolome. Our results are based on pooled samples and the influence of LPS in modulating metabolites in CTL diet during the first 48h post challenge was demonstrated with the strongest response occurring at T12h.

The main dietary effect was observed when CTL and CTS were compared at T12h post LPS challenge. In CTS at this time point the expression of entire amino acids and energy pathways were modified. Comparing the CTL and CMB diet revealed only a few differences, this occurred mainly at T12h, but the metabolites concerned were associated with secondary pathways and therefore were of little biological interest, so our attention was again focused on CTS diet.

Effects of LPS on the liver metabolome

In this study, LPS was found to modulate the liver metabolome of broilers at all time points with the biggest impact occurring at T12h. Because many intermediates were modulated, entire metabolic pathways were influenced. This result is consistent with the data from our LPS plasma metabolome study (chapter 5) and represent a further confirmation of the strong influence of this non infectious agent on broiler metabolism. In both the liver and plasma, LPS causes an imbalance in the abundance of amino acids. As discussed in chapter 3, due to the activation of the immune system and the associated reduction in broiler feed intake following an LPS challenge, a dysregulation of nutrient homeostasis causes imbalance in amino acids detected in both the plasma and the liver metabolome. As previously discussed in chapter 4, under challenge conditions amino acids can also be released from skeletal muscle into the circulation and used for hepatic production of APPs and gluconeogenesis, as well as immunological processes (Barnes et al., 2002). It would therefore of interest to look at the muscle metabolome following LPS challenge.

Intermediates of the Citrate cycle also decreased in the liver at T12h post challenge. Again, this is consistent with the results of the plasma metabolomics study. LPS is known to decrease metabolites involved in energy and carbohydrate metabolism (Bicer et al., 2009). As previously indicated, broilers suffer from anorexia post LPS challenge and consequently their metabolism changes to hepatic gluconeogenesis to support the energy requirements of

tissues and organs (Rosenblatt, 1983). Hepatic gluconeogenesis partly uses intermediates of the Citrate cycle which can be generated from the degradation of several amino acids including Alanine, Arginine, Asparagine, Methionine.

Effects of diets on liver metabolome

A significant and strong modulation of many metabolites and entire pathways was discovered in the CTS diet especially at T12h post LPS challenge (49 identified metabolites and >2000 annotated metabolites). CMB also showed some modulation of metabolites at T12h, but as these were small, they were considered of little value and so these were not considered further.

Multiple pathways including many essential and not essential amino acids were modulated by CTS diet. Among these, alanine which is one of the intermediates in glucose metabolism significantly increased. A primary function of alanine is as a signalling molecule in gluconeogenesis between muscle and liver (Fotakis et al., 2017). According to these authors, Alanine is the main glucogenic amino acid, produced by muscle degradation. This supported our hypothesis under challenge conditions, broilers may mobilize AA from muscle to meet the energy needs of other tissues and organs.

Based on these results, the interaction between citrus bioactive compounds which could be responsible for the modulation of entire metabolic pathways and specific metabolites was explored. Pectin is able to escape digestion and participates in the immune response of broilers *in vitro* (Ávila et al., 2021); however, the mechanism of action *in vivo* has not been determined. Ávila et al. (2021) demonstrated that citrus pectin has interesting effects on the APR in particular modulating the response of monocytes and reducing APP release leading to an increase in metabolic intermediates of amino acids, carbohydrates, lipids and nucleotide metabolisms Thus these findings in the broilers fed with citrus diet are an indicator of higher energy availability which may help broilers to recover faster from challenge.

Carotenoids and essential oils were also demonstrated in chapter 2, to influence the growth of beneficial bacteria which are involved in the production of SCFAs at the gut level. SCFAs are recognised to be involved in reducing inflammation and regulation of the metabolism. In particular glucose metabolism has been demonstrated to be modulated by SCFAs so

allowing the maintenance of blood glucose stability. SCFAs can also increase fatty acid oxidation and heat production, inhibit fatty acid synthesis, and reduce fat storage (He et al., 2020). SCFAs have demonstrated a strong ability in the regulation of metabolism, but the entire network is very complex, and so the molecular mechanisms remain unclear as most of metabolites participate in multiple metabolic pathways. Thus when the lipid or energy metabolism is modified, this alteration is likely to be cause repercussions throughout the whole metabolome.

Finally, the flavonoids in CTS diet such as hesperidin and naringenin seem to enhance the action of citrate synthase and stimulate the Citrate cycle (Kamboh et al., 2016). This could explain higher concentration citrate cycle intermediates by using CTS dietary treatment. Hesperidin and naringin have been proven to have a beneficial role in altering hepatic lipid metabolizing enzyme activities so regulating lipid metabolism (Fotakis et al., 2017). Betaine was discovered to be the most increased metabolite by CTS diet at T12h; this metabolite is involved in antioxidant defence by regulating sulfur-amino acid metabolism. Its increased concentration could be explained as counteracting the high lipid content. Betaine increases the activity of antioxidant enzymes, so it protects against lipid peroxidation (Fotakis et al., 2017). Different studies have demonstrated that antioxidant and anti-inflammatory agents are also beneficial in LPS-induced hepatic damage, so flavonoids can reduce oxidative stress and relieve tissue injuries by its antioxidative properties (Ajuwon et al., 2014).

These considerations suggest that bioactive compounds of citrus may have a direct or indirect action on the abundance of specific metabolites (e.g. reducing the inflammatory response or modulating any bacterial challenge). In this liver study, the CTS diet has been demonstrated to stimulate amino acids, carbohydrates, lipids and nucleotide metabolisms indicators of higher energy and protein availability. These may help the broilers to recover faster from challenge such as the LPS here. This result was found in line with our findings on plasma metabolome (chapter 5), but interestingly the effect of the citrus extract was found to be greater in liver than plasma. This difference observed between plasma and liver metabolome in terms of number of identified metabolites and entire pathways modulation was not expected as liver is the main tissue for many metabolic pathways, and since plasma metabolites are largely released from liver, one would expect it to reflect the tissue results. This may be a matter of liver sample size (pooled samples) so further investigation would help to clarify this.

Conclusions

LPS challenge and CTS diet were identified to modulate the overall liver metabolome of broilers with a strong impact at T12h post challenge. LPS was confirmed to decrease the abundance of amino acids and carbohydrates at the liver level, by reflecting the previously shown results on the plasma metabolome (chapter 5). The effect of CTS diet was found strong as well; amino acids and metabolites associated to energy metabolism were found upregulated by the diet. Our results suggest that citrus bioactive compounds such as pectin, essential oils, carotenoids and flavonoids, may infer the immune system or stimulate the growth of beneficial bacteria during challenge. This would indicate that broilers fed with CTS diet may recover faster post challenge.

In the next chapter a general discussion which integrate microbiota, APPs, proteomics and metabolomics (plasma and liver) results will be aimed to clarify and define the role of LPS and citrus during normal physiological conditions and APR in broilers.

Chapter 7 General discussion

7.1 Citrus and Cucumber extracts as antibiotics growth promoters' alternatives

The meat production side of the poultry industry is a low profit margin industry which is facing challenging times due to intensification and the associated elevated risk of disease. Historically this led to the widespread prophylactic use of some common antibiotics to control disease which were also found to improve growth rate. However bacteria and viruses are constantly evolving and this has significantly contributed to the appearance of antimicrobial resistant (AMR) pathogens (Landers et al., 2012). This has led to a number of countries banning their prophylactic use and limitations on the use of antibiotics in general. For this reason, the animal feed industry has a need to identify alternatives to these additives. Novel plant extracts, such as citrus (CTS) and cucumber (CMB) extract, have been identified, in collaboration with NuScience company, as potential candidates for use in broiler diets. At the start of this PhD NuScience had already undertaken studies with the CTS extract with some encouraging results whereas the CMB extract was more exploratory in choice because of its bioactive components. The aim of this thesis was to establish if broiler diets supplemented with CTS or CMB extract confer any advantage over a control baseline diet in terms of bird performance by for example enhancing gut health and /or increasing bird resilience to a LPS challenge that mimics a gram negative bacterial infection (*E.coli*). As the work was carried out as part of MANNA (<http://www.phd4manna.eu>), it was possible to apply a wide range of innovative technologies to study each supplement, the key findings of which are discussed in this final chapter.

7.2 Effect of CTS and CMB diets on broilers under normal physiological conditions

The study of the overall microbiota composition and gut health of broilers, fed with CTS or CMB, investigated the role of these as potential 'growth promoters' under normal rearing conditions (trial 1; chapter 2). This study demonstrated that both CTS and CMB supplemented diets can modulate the growth of beneficial bacteria in both the jejunum and caeca at 14 and 28d old. However, the biggest effect was found associated with the use of CTS where a number of beneficial bacteria including *Lactobacilli* increased in the jejunum, and *Blautia* increased in the caeca. Other potential pathogenic bacteria decreased in the jejunum (*Enterococcus*

and *Clostridia*) and caeca (*Enterococcus*). These results were found in accordance with the existing literature (Yu et al., 2019; Ebrahimi et al., 2016; Mao et al., 2019).

Polyphenols, essential oils and vitamins associated with CTS extract were hypothesised to be associated with the increased concentration of *Lactobacilli*, which allow the fermentation of dietary fibres to produce SCFAs, while carotenoids and polyphenols may be responsible for the observed decreasing count of *Clostridium* and *Enterococcus* genus (Iqbal et al., 2020). The latter hypothesis is supported by Marín et al., (2015) who found that the abundance of *Lactobacillus*, *Clostridium* and *Enterococcus* was respectively increased and decreased by polyphenols. Organic acids or SCFAs produced by beneficial bacteria (especially by *Lactobacilli*) can reduce the pH and alter the caecal count of *Blautia* genus (Yadav and Jha, 2019; Kumar et al., 2019). SCFAs are well known to be a source of energy for enterocytes and exert antimicrobial properties against pathogenic bacteria, and can also influence the broilers metabolism (Yadav and Jha, 2019; Mao et al., 2019). The mechanisms of action of these bioactive compounds needs to be clarified, but further insight can be obtained from the current work by comparing the microbiota (chapter 2) results with those from the metabolomics investigations reported in chapters 5 and 6.

Based on the plasma metabolomics study in broilers at 15d old (chapter 5), CTS was found to be strongly involved in the modulation of plasma metabolome during normal physiological conditions (T0h). However, due to the nature of metabolites (annotated or unknown) it was not possible to establish their biological role. The plasma and liver metabolome (chapter 6) in CTS diet pre challenge was compared but interestingly no CTS modulation at T0h was noted in liver. Possible explanations of the plasma metabolome influenced by CTS diet were associated to bacterial activity on broilers metabolism. *Lactobacilli* catabolise sugars present in food during the fermentation process and produce lactic acid. These bacteria also have the capability to metabolize other substrates, such as Citrate and promote absorption of nutrients (Rowland et al., 2018). Because I am comparing the results of two different trials, I cannot say with certainty that this is the mechanism of action but nevertheless it is plausible as the environmental conditions and facilities used for the two *in vivo* trials were comparable.

It is clear from the literature that beneficial bacteria such as *Lactobacilli* should promote gut health; for this reason, tissue samples of the jejunum collected at 14 and 28d old from each dietary treatment were compared (chapter 2). Morphometric parameters such as villus

length, epithelium height and crypt depth are commonly used as indicators of gut health status in both human and veterinary medicine (Ducatelle et al., 2018). However, in our study, no differences were observed indicating that the beneficial effects of *Lactobacilli* on the jejunum were more subtle. However, thanks to the availability of tissue samples collected during the trial, it would be interesting to investigate other regions of the GIT.

Follow up work is also recommended to investigate the interaction between the CTS diet and the gut microbiota. For example, a study to measure the concentration of SCFAs such as lactic acid, acetate, propionate, and butyrate by HPLC, could define if their production is positively correlated to the relative abundance of *Lactobacillus* or *Blautia* genus (Pourabenin et al., 2015). Gut viscosity could also be evaluated to determine if the positive effects of CTS bioactive compounds can be associated with a reduction in viscosity of jejunal and caecal contents. Another approach could be to carry out *in-vitro* experiments which investigate the impact of the known active compounds in the CTS extract, such as flavonoids, pectin or limonene on bacterial strain cultures. If citrus bioactive compounds would increase the growth of bacteria, a higher number of colonies would be observed in the agar plate cultured with bacteria+ CTS bioactive compounds compared to a negative control (only bacteria). Ideally, I would have collected plasma samples from the first trial for the metabolomics studies of broilers under normal physiological conditions. This would have allowed direct comparisons with the microbiota study and enabled us to better clarify the mechanism of action of bacteria in modulating metabolic pathways and specific metabolites. Moreover, the microbiota is very dynamic so different time points with broilers age could show different outcomes. Future studies should also therefore consider evaluating the influence of CTS at multiple sampling time points. Finally, in designing a future experiment, it would be useful to include a positive control, namely an antimicrobial growth promoter such as virginiamycin. However, because of their ban, many legal and ethical considerations would have to be overcome.

For a dietary supplement, to be acceptable the evidence base usually also requires that there is a beneficial effect in terms of bird performance e.g BW, FI and FCR. Broiler performance was therefore also studied in trial 1 (chapter 2). Based on the data, CTS was found to decrease the FI and BW, and to increase FCR. BW and FI was also depressed in the CMB diet. This scenario did not correspond to the one observed in trial 2 (chapter 3) where the FI was increased by CTS diet. This last scenario is supported by the literature because citrus extract can stimulate the appetite of broilers (Krauze et al., 2021). Moreover, according to

NuScience zootechnical data, our CTS results do not reflect bird performance recorded in a commercial setting. This highlights a common problem of trying to translate zootechnical data results from small scale experiments to commercial trials and vice versa.

Based on our studies, the CTS extract appears to be promising in terms of promoting the growth of some beneficial bacteria which can consequently improve the absorption of nutrients while the CMB extract was found to have little effect. The impact of diets supplemented with the CTS extract however was quite subtle but along with the NuScience zootechnical data these findings were nevertheless encouraging and justified further work on the role of both supplements in relation to disease resilience.

7.3 Effect of Citrus and Cucumber extracts on broilers under LPS challenge

The influence of each dietary supplement on the APR following a *E. coli* LPS challenge was studied in 15-day old broilers over a time course of 48 hours. The reference time points chosen, pre and post challenge, were respectively T0, 12, 24 and 48 hours. These time points were chosen based on previous knowledge (Horvatić et al., 2019) and practicalities in terms of timing the administration of LPS and the time taken to bleed and sample individual each individual bird. If further measures were to be taken a much larger team of personnel would be required than was available here (6 persons).

Some of the bioactive compounds present in citrus fruits (e.g pectin and flavonoids) and their positive effects on modulating the immune response have been studied *in vitro* (Ávila et al., 2021; Ishisono et al., 2017; Muhammad et al., 2019). However, to the best of our knowledge this is the first *in vivo* study of its kind where novel biomarkers of the APR are presented along with detailed information on the effects of dietary intervention (CTS and CMB diet) on the proteome and metabolome of broilers pre and post LPS challenge.

In this study I was fortunate to have been given access to a range of established and novel assays to measure APPs, so this was our first approach in studying the immunomodulatory effect of the CTS and CMB diets. Whilst was able to demonstrate with confidence that I had induced an APR at T12h post LPS injection (see 7.4 Broilers immune response to LPS and

biomarkers discovery), no differences in APP responses were identified between diets using any of the established (AGP and SAA) or more novel biomarkers (Ex-FABP, Hpx) (chapter 3).

Most APPs in plasma originate from the liver (O'Reilly and Eckersall, 2014). The mobilisation of skeletal muscle proteins also occurs during the immunological response to stress to supply amino acid precursors for the APP (Powers et al., 2016). Thus, the liver and muscle proteome are linked and were therefore studied in chapter 4 to investigate if more subtle dietary effects could be detected on the proteome of these two tissues. 12 hours post LPS challenge was chosen as the main target time for these proteomic studies. This revealed that CTS supplementation influenced both the liver and muscle proteome when compared to the CTL diet while CMB had little or no effect. In the liver proteome, Isoforms of heat shock proteins (Hsp70 and Hsp90) and metabolic enzymes (LDHA, fructose-bisphosphate aldolase) were found to be decreased and increased respectively in the CTS versus CTL diet while in the muscle proteome, metabolic enzymes (GAPDH) and structural proteins (myosin, tubulin) were found to be increased.

The literature suggests that liver and muscle proteomic studies have a physiological relevance associated with specific diseases and metabolic conditions (Doherty et al., 2004; Hassan et al., 2018). Under stress conditions, the activation of muscle breakdown occurs in broilers to provide AA substrates to liver gluconeogenesis to supply energy (Gordon et al., 2013). Western Blot (WB) results for 3 of the differentially expressed proteins (HSP90, LDHA and GAPDH) identified in these studies were inconclusive but the overall trend in the CTS versus the CTL diet reflects the proteomics data. The choice of which proteins to validate was somewhat limited to the availability of species-specific commercial antibodies and with exception of GAPDH the presence of each protein was confirmed in both liver and muscle. Further refinements for example in the processing of the tissue samples and or using a greater number of samples may also help to improve the statistical power of the WBs and should be considered if this work is to be repeated. Despite all of these limitations the results of the proteomic investigation support the hypothesis that CTS may indeed offer at least some resilience to gram negative bacterial infection and possibly even other agents by positively modifying the metabolism of broilers following LPS challenge. One of the limitations of this proteomics study has been the choice of only one time point (T12h post challenge). Further investigations however are required to clarify this beyond the time point chosen for this investigation. A further proteomics experiment with higher doses of CTS per

bird and a greater number of chicken samples per group would also enhance the statistical power and yield significant results.

The proteomics and microbiota studies indicate an interaction between CTS diet and the metabolism of broilers either by a direct action of bioactive compounds on enzymes or through beneficial bacteria pre and post LPS challenge. The CTS diet was found to modulate the plasma metabolome under normal physiological conditions (T0h) and both the plasma and liver metabolome T12h post LPS challenge while CMB did not show any differences. In the liver metabolome study, multiple amino acids (e.g. Cysteine, Methionine, Arginine, Proline) and carbohydrate metabolites (e.g Citrate) were found to be significantly modulated by CTS at T12h post challenge; all of these changes indicated a shift in energy production: amino acid catabolism was induced as an energy source, as well as the Citrate cycle. This indicates that, broilers fed with CTS diet during LPS challenge have higher carbohydrate and amino acid availability compared to broilers fed with the CTL diet. This result suggests that CTS provides a higher abundance of metabolites to broilers which can be used as a source of energy for broilers to contrast their sickness and pyrexia state during challenge. This result is in accordance with our proteomics findings which suggest that CTS can stimulate the metabolism by increasing the number of metabolic enzymes (chapter 4).

In the liver, most metabolites significantly modulated by CTS diet were identified based on mass and retention time which gives a more accurate interpretation of the overall data while in plasma most metabolites were assigned putatively based on mass. For this reason, in the plasma metabolome, our attention was concentrated on the abundance of Adenosine (the main identified metabolite) which in the CTS was lower than that of the CTL birds at T0h and T12h post challenge compared to the CTL diet at the same time points. Adenosine plays an important role in the modulation of the immune system and during inflammation or stress conditions, its plasma level dramatically increases (Antonioli et al., 2019). Many citrus bioactive compounds such as pectin, flavonoids, and limonene could be responsible for the difference in Adenosine associated with the CTS diet. Pectin and Gal-3 in citrus for example may be able to suppress pro- inflammatory pathways induced by LPS which meant that the birds experienced less stress. This hypothesis however was not confirmed by carrying out a corticosterone assay on plasma collected pre and post challenge from the CTS versus CTL groups. The affinity of flavonoids and limonene to Adenosine receptors suggests that CTS diet may also block the effects of intracellular Adenosine resulting in an increase in free extracellular adenosine. To investigate these hypotheses, follow up *in vitro* studies might

include affinity testing of a range of bioactive compounds known to be present in CTS (pectin, flavonoids and limonene) and interact with Adenosine and its receptors using high performance liquid chromatography (HPLC).

A limitation of the liver metabolomic study was that this relied on a pooled sample approach. However, our two-pronged approach to investigate the plasma proteome suggests that studies on pooled and individual samples were comparable. A search of the literature research also show the positive side of analysing pooled samples: Diz et al. (2009) stated that by pooling samples, the reduction in the measured biological variation increases statistical power and because pooling is representative of averages, differences or similarities may be easier to elucidate. Lamichhane et al. (2017) suggested that pooling samples of human faeces minimizes the errors between individual subjects' variation. A pooled sample approach has also been used in metabolomics studies of bovine milk (Yanibada et al., 2018), and human milk (Ten-Doménech et al., 2020). A further limitation of metabolomics in general is that the results are only representative of the animal's metabolism at the time of sampling and in this case in response to a single LPS subcutaneous injection. Future work should therefore consider alternative sampling regimens and modes of LPS administration.

In conclusion, this body of work has shown that broiler diets supplemented with CTS extract show interesting immunomodulatory and metabolic effects while broiler diets supplemented with CMB extract were not associated with any specific changes pre or post LPS challenge. Moreover, the strongest action of CTS was observed in the plasma and liver metabolome.

7.4 Broilers immune response to LPS and discovery of new biomarkers

As previously discussed, a range of established and novel APPs were used in this thesis to measure the APR of broilers in our dietary investigations. SAA is the gold standard used by many researchers to monitor the APR in a range of species including chickens. In our experiments Ex-FABP was found to be comparable to SAA in that its levels peaked in plasma at T12h post challenge. AGP another established biomarker and Hpx our other novel APP, both peaked at T24h post challenge. SAA and Ex-FABP was therefore classified as major APPs of the APR in broilers. In the same way, AGP and Hpx were both classified as

moderate APPs of the APR in broilers. Although in the context of the thesis the APP study did not reveal any interesting effects of dietary supplementation with CTS or CMB, the work presented has enabled Ex-FABP and Hpx to be validated as novel biomarkers of APR in broilers under the prescribed experimental conditions. The commercial kits developed for these novel proteins can therefore be used with confidence by other researchers.

A massive modulation of proteins associated with the liver and muscle proteome was expected following the LPS challenge. However, the proteomics study described in chapter 4 did not reveal this to be the case in either the liver or the muscle at T12h post challenge. Moreover, SAA, AGP, FABP and Hpx were not included in the list of significant proteins in the liver that were modulated by LPS. This was surprising as most APPs are produced in the liver (O'Reilly and Eckersall, 2014) and as previously mentioned their abundance in the plasma was noticeably increased at T12h (see chapter 3). SAA was detected by the instrument but as there were less than two unique peptides, this data was filtered out by the instrument. AGP, FABP and Hpx on the other hand were not detected. One of the possible reasons for this result could be that these APPs were being synthesised so rapidly by the liver and exported to serum that no overall increase in their abundance was observed. However, both alpha 2 macroglobulin and fibrinogen (Jain et al., 2011) were detected. Both of these APPs have been confirmed by other studies in humans and livestock to increase in their abundance during an inflammatory response (Vandooren and Itoh, 2021; Jacobsen, 2007; Tothova et al., 2014; Salini et al., 2011). To the best of our knowledge alpha2 macroglobulin has never been described in relation to the APR response of chickens.

The overall plasma metabolome (chapter 5) of broilers was found to be modulated by LPS at all time points post challenge with the biggest effect occurring at T12h. This corresponds to the peak of the innate immune response based on our APP study and that of others (Horvatić et al., 2019; O'Reilly and Eckersall, 2014). Multiple amino acids and carbohydrate metabolites were found to be significantly modulated presumably because when the immune system is activated the degradation of amino acids in the liver and other tissues is initiated and there is a shift the Citrate cycle from a catabolic pathway to anabolic pathway (Martínez-Reyes and Chandel, 2020). Our results were compared to the study of Horvatić et al. (2019) which focused on proteomics changes in the plasma, using the same experimental model and conditions. These authors showed that many proteins were either increased or decreased in the plasma at T12h post LPS challenge. This implies that

corresponding amino acids associated with these proteins would be changing which is in line with our findings.

As previously indicated, it is important to consider that all of the results reported in this thesis relate to the immune response in broilers following a single dose of LPS administered by injection subcutaneously; it would therefore be of interest to extend this work by studying the APR of broilers using these different technologies under repeat administration of LPS or using another bacterial mediator.

7.5 Conclusions

The studies described in this thesis aimed to evaluate the effects of two novel plant extracts, (CTS and CMB) on broiler performance during normal physiological conditions and also following an LPS challenge condition. These two novel extracts were chosen on the recommendation of our industry partner NuScience who reported that because of their bioactive components showed considerable promise as alternatives to the use of antibiotics as growth promoters in broiler diets.

Based on our experimental findings, I could find no evidence to justify the inclusion of the CMB extract in broiler diets either in terms of enhancing gut health or providing resilience to disease. In discussion with NuScience it was concluded that further work is perhaps needed to a) optimise the extraction procedure used to produce the CMB extract and b) the optimal concentration to use in broiler diets. The CTS extract on the other hand was found have subtle effects on the gut microbiota and to have an effect on metabolome of both the liver and plasma pre and post challenge for up to 48h. The liver and muscle proteome were also influenced albeit more subtly by the CTS in the early phase (T12h post challenge) of the immune response. Further investigations on metabolic enzymes influenced by CTS and an increased frequency of sampling, larger numbers and different concentration of the extract would help to clarify the role of CTS in terms of modulating the proteome of broilers under challenge conditions.

I conclude that of the two novel plant extracts studied in this thesis the use of CTS extract in broiler diets is the most promising in terms of promoting gut health and enhancing the immune system. However even with the evidence base generated here there still remains

more work to do in order to understand the mechanism of action of the CTS extract bioactive compounds in order to justify the additional costs of its inclusion in commercial broiler diets.

Appendices

Appendix A - Microbiota

QIIME™ scripts

Several scripts that run systematically compose the workflow of the QIIME™ bioinformatics analysis described above. Every time an input file with specific parameters is uploaded on QIIME™, it creates a specific output file or a folder with the resulting data. From the 132 samples analysed with QIIME™, 3 were excluded because of the low number of sequences (< 5000 count/sample). The scripts used for our analysis are described below:

- **Split_libraries_fastq.py**

It performs demultiplexing of fastq sequence data where barcodes and sequences are contained in two separate fastq files.

- **add_qiime_labels.py**

The metadata mapping file with samples information is used to generate a combined fasta file with valid QIIME labels based upon the SampleIDs specified in the mapping file.

- **pick_open_reference_otus.py**

The OTU picking step assigns similar sequences to operational taxonomic units, or OTUs, by clustering sequences based on a user-defined similarity threshold. Sequences that are similar at or above the threshold level are taken into account to represent the presence of a taxonomic unit in the sequence collection. There are 4 possible OTU Picking:

- **De novo OTU picking**

Reads are clustered against each other without any external reference sequence. This is the primary interface for de novo OTU picking in QIIME, and includes taxonomy assignment, sequence alignment, and tree-building steps. A benefit of de novo OTU picking is that all reads are clustered. A drawback is that there is no existing support for running this in parallel in QIIME, so it can be too slow to apply to large datasets. It's important to use this OTU picking if there is not a reference sequence collection to cluster against.

- **Closed-reference OTU picking**

Reads are clustered against a reference sequence collection and any reads that do not hit a sequence in the reference sequence collection are excluded from downstream analyses. If the user provides taxonomic assignments for sequences in the reference database, those are assigned to OTUs. It is important to use this OTU picking if non-overlapping amplicons are compared.

- **Open reference OTU Picking:**

reads are clustered against a reference sequence collection and any reads that do not hit the reference sequence collection are subsequently clustered de novo. It is the primary interface for open-reference OTU picking in QIIME™, and includes taxonomy assignment, sequence alignment, and tree-building steps. In pick-open reference OTUs all of the sequences from the samples are matched against the reference sequences, as well in closed

reference OTUs, with a determined threshold, traditionally set at 97% of sequence similarity. Sequences with almost 97% of similarity are clustered into Operational Taxonomic Units (OTUs) as well in the de novo strategy. UCLUST is the algorithm that divides sequences into clusters and each one represents a bacteria species. The fasta file `seqs_rep_set.fasta` contains one representative sequence for each OTU. This representative sequence will be used for taxonomic identification of the OTU and phylogenetic alignment. Therefore, the RDP classifier connects the OTUs to named organisms. The QIIME workflow proceeds with the sequence alignment with PyNAST creating phylogenetic tree that represents the evolution of sequences from a common ancestor.

- **core_diversity_analyses.py**

This script can lead to several QIIME diversity analyses using a BIOM table, mapping file, and optional phylogenetic tree. The script includes:

`the_alpha_rarefaction.py`,

`beta_diversity_through_plots.py`,

`summarize_taxa_through_plots.py`,

`make_distance_boxplots.py`,

`compare_alpha_diversity.py`,

`group_significance.py`.

Additionally, a table summary is generated by running the ‘`biom summarize-table`’ command. Once its run ends, the alpha diversity that means “difference within bacterial community in each sample” is explored and a rarefaction curve referred to each specific experimental variable is generated and evaluated the richness, evenness, or both, of samples. Beta diversity considers the differences in microbial communities between samples, and it is calculated between each pairs of input samples and form distance matrices that represent the dissimilarity among samples. This script needs a `rep_set.tre` in order to elige which phylogenetic distance matrix to use.

- **Koeken_Runs.py**

Koeken is a wrapper around QIIME and LEfSe which allows the identification of specific microbial species as biomarkers of a specific treatment or variable of interest. It has been specifically developed for experiments which uses more than one group to compare. It has the capability to compare a chosen group to another, without any additionally subsetting.

Appendix B - Proteomics

Proteomics study 2 on liver: effects of CTS diet at T12h post LPS challenge

Accession ID	Description	gene name	Unique,Peptides	medianCTL	medianCTS	Fc	Log fc	p
118082784	ATP-dependent RNA helicase DDX17	DDX17	4	1.046	0.952	0.910	-0.136	0.002
971434955	alpha-2-macroglobulin-like protein 1	A2ML4	7	1.083	0.924	0.853	-0.229	0.002
971408766	phosphoglucomutase-1 isoform X1	PGM1	6	0.836	1.058	1.266	0.340	0.003
63509	Heat shock protein 90 kDa beta member 1	HSP90B1	8	1.015	0.976	0.962	-0.057	0.004
134800	Spectrin alpha chain, non-erythrocytic 1	SPTAN1	12	1.044	0.950	0.910	-0.136	0.004
211827	78-kD glucose-regulated protein precursor	HSPA5	9	1.053	0.993	0.943	-0.085	0.005
53135191	hypothetical protein RCJMB04_24j16	LRPPRC	3	1.029	0.977	0.949	-0.075	0.005
33331366	phosphoglucomutase 1	PGM1	8	0.916	1.078	1.177	0.235	0.005
50729534	homogentisate 1,2-dioxygenase	HGD	4	1.047	0.950	0.908	-0.140	0.006
63516	heat shock protein HSP 90-alpha	HSP90AA1	13	1.015	0.951	0.937	-0.094	0.007
126046	L-lactate dehydrogenase A chain	LDHA	2	0.916	1.134	1.238	0.308	0.007
1334744	spectrin alpha chain	SPTAN1	11	1.045	0.950	0.909	-0.138	0.008
113610	Fructose-bisphosphate aldolase B	ALDOB	13	0.984	1.108	1.126	0.171	0.009
971425748	NADPH--cytochrome P450 reductase isoform X2	POR	6	1.048	0.994	0.948	-0.076	0.009
53127632	heat shock 70 kDa protein 9	HSPA9	7	1.012	0.973	0.961	-0.057	0.010
53132642	hypothetical protein RCJMB04_1317	PDIA4	6	1.042	0.940	0.902	-0.149	0.012
694016481	40S ribosomal protein S28	RPS28	2	0.996	0.917	0.921	-0.119	0.013
1390057732	40S ribosomal protein S19	RPS19	2	1.029	0.980	0.952	-0.070	0.014
971185	fibrinogen alpha-E subunit	FN1	3	1.124	0.956	0.851	-0.234	0.015
8569621	Chain A, Native Chicken Fibrinogen	FGA	3	1.124	0.956	0.851	-0.234	0.015
1390063686	alpha-2-macroglobulin isoform X1	A2M	3	0.991	0.877	0.885	-0.176	0.015
971438075	histidine triad nucleotide-binding protein 2	HINT2	2	1.049	0.981	0.935	-0.097	0.016
971425736	NADPH--cytochrome P450 reductase isoform X1	POR	7	1.048	0.993	0.948	-0.078	0.020
304277331	NADPH-cytochrome P450 oxidoreductase	POR	4	1.048	0.994	0.948	-0.076	0.021
971450877	NADH dehydrogenase beta subcomplex subunit 7	NDUFB7	2	0.998	1.179	1.181	0.240	0.022
118094989	coatamer subunit beta	COPB2	3	1.086	0.982	0.904	-0.145	0.023
65322	heat shock protein 90 beta	HSP90AB1	4	1.002	0.934	0.932	-0.101	0.025
971442707	retinol dehydrogenase 12 isoform X1	LOC107056277	3	0.962	1.062	1.104	0.143	0.026
44969651	calreticulin	LOC100859104	2	0.994	0.917	0.923	-0.116	0.029
3641556	fibrinogen gamma chain precursor	FGG	2	1.090	0.903	0.828	-0.272	0.029
71896197	polyadenylate binding protein 1	PABPC1	5	1.006	0.965	0.959	-0.060	0.029
50657412	cytochrome P450 family 4 subfamily V member 2	CYP4V2	2	1.171	1.088	0.929	-0.107	0.030
60099043	hypothetical protein RCJMB04_21b18	HNRNPH3	4	1.068	0.957	0.896	-0.158	0.031
971445900	delta(3,5)-Delta(2,4)-dienoyl-CoA isomerase	ECH1	7	0.956	1.045	1.093	0.128	0.035
513204295	6-phosphofructo-2-kinase/fructose-2,6-bisphosphatase 4 isoform X3	LOC100859653	3	1.036	0.926	0.894	-0.162	0.039
363734138	acetyl-coenzyme A synthetase 2-like, mitochondrial isoform X1	LOC423347	5	0.923	1.007	1.090	0.125	0.039
118092591	putative hexokinase HKDC1	HKDC1	4	0.926	1.028	1.110	0.151	0.040
45383538	NADP-dependent malic enzyme	ME1	11	1.003	1.041	1.038	0.054	0.043
1390115922	heterogeneous nuclear ribonucleoprotein H3 isoform X5	HNRNPH3	3	1.039	0.955	0.919	-0.122	0.044
45384446	60S ribosomal protein L27	RPL27	3	1.055	0.961	0.911	-0.135	0.044
45382571	40S ribosomal protein S6	RPS6	2	1.042	0.926	0.889	-0.170	0.045
50754810	catenin alpha-1	CTNNA1	3	1.060	1.000	0.943	-0.084	0.046
1390106239	peptidyl-prolyl cis-trans isomerase FKBP11	PPIA	2	1.056	0.878	0.831	-0.267	0.047
71896389	ATP-citrate synthase	ACLY	24	0.970	1.038	1.070	0.098	0.048
513230931	heterogeneous nuclear ribonucleoprotein K isoform X3	HNRNPK	5	0.895	0.996	1.113	0.154	0.049
50745031	protein disulfide-isomerase A6	PDIA6	5	0.995	0.939	0.944	-0.084	0.049

Table 8.1 Significant proteins ($p < 0.05$) of CTS diet at T12h vs CTL diet at T12h in liver samples

List of significant protein with differences in abundance between groups associated to unique genes with the median in CTS and CTL diets (relative to internal standards), fc, Log fc and p-value. Proteins are listed, in order starting from the lowest in p . Proteins listed in order of increasing p .

Proteomics study 2 on muscle: effects of CTS diet at T12h post LPS challenge

Accession	Description	gene name	Unique Peptides	medianCTL	medianCTS	fc	Log fc	p
63433	unnamed protein product, partial	H2AFJ	2	1.067	0.878	0.823	-0.281	0.000
63439	unnamed protein product, partial	HIST1H2A4	2	1.067	0.878	0.823	-0.281	0.000
63448	unnamed protein product	LOC1017505	2	1.067	0.878	0.823	-0.281	0.000
63466	unnamed protein product	H2AFV	2	1.067	0.878	0.823	-0.281	0.000
971416845	histone H2A type 2-B	LOC1017517	2	1.067	0.878	0.823	-0.281	0.000
118097461	myozenin-3	MYOZ3	4	1.093	0.914	0.836	-0.258	0.001
45382147	tudor-interacting repair regulator protein precursor	NUDT16L1	4	1.155	0.902	0.781	-0.357	0.001
9789730	Sarcoplasmic/endoplasmic reticulum calcium ATPase 2	ATP2A2	4	1.156	0.852	0.737	-0.440	0.002
238273	myosin heavy chain 22 kDa fragment [chickens, skeletal muscle, Peptide Partial, 197 aa]	MHC	2	1.091	0.862	0.790	-0.340	0.005
773669241	myomesin-1	MYOM1	15	1.159	0.943	0.814	-0.298	0.006
60098993	hypothetical protein RCJMB04_18g2	HK1	5	1.027	0.887	0.864	-0.211	0.008
294662216	Chain M, MYOSIN HEAVY CHAIN, SKELETAL MUSCLE	MHC	4	1.119	0.910	0.813	-0.298	0.009
62738642	Chain A, Annexin A5	ANXA5	2	1.081	0.884	0.818	-0.290	0.009
971414380	phosphorylase b kinase regulatory subunit beta isoform X2	PHKB	9	1.077	0.889	0.825	-0.277	0.010
513180238	phosphorylase b kinase regulatory subunit alpha, skeletal muscle isoform isoform X6	PHKA1	8	1.094	0.904	0.826	-0.275	0.011
212834	beta-tubulin	TUBB1	3	1.155	0.922	0.798	-0.325	0.011
459714	beta-5 tubulin	TUBB	4	1.155	0.949	0.822	-0.283	0.012
17974316	DJ-1	PARK7	3	0.957	1.335	1.395	0.480	0.013
53129115	hypothetical protein RCJMB04_5g20	PGAM1	4	0.790	1.243	1.573	0.654	0.016
13432175	RecName: Full=Myosin heavy chain, skeletal muscle, adult	MYH1E	15	1.095	1.006	0.919	-0.122	0.016
238274	myosin heavy chain [chickens, skeletal muscle, Peptide, 1938 aa]	MHC	15	1.094	1.008	0.921	-0.118	0.016
238272	myosin heavy chain 50 kDa fragment	MHC	2	1.178	0.993	0.843	-0.246	0.017
212659	skeletal muscle C-protein, partial	MYBPC2	22	1.099	0.834	0.759	-0.398	0.019
71896203	tubulin beta-4 chain	TUBB3	5	1.071	0.956	0.893	-0.164	0.024
53136740	hypothetical protein RCJMB04_33d2	PFKP	3	1.063	0.926	0.871	-0.199	0.026
1706654	Beta-enolase	ENO3	7	0.901	1.171	1.300	0.378	0.028
118099967	ATP synthase subunit d, mitochondrial	ATP5H	2	0.746	1.016	1.362	0.446	0.028
135464	Tubulin beta-3 chain	TUBB4B	7	1.043	0.970	0.930	-0.105	0.028
212868	vimentin	VIM	7	1.034	0.681	0.659	-0.603	0.029
135446	Tubulin beta-1 chain	TUBB2B	7	1.046	0.969	0.926	-0.110	0.030
61098440	calcium-binding mitochondrial carrier protein Aralar2	SLC25A13	2	0.845	1.030	1.219	0.286	0.032
1390110269	phosphorylase b kinase regulatory subunit alpha, skeletal muscle isoform isoform X1	PHKA2	10	1.094	0.970	0.887	-0.174	0.033
135474	RecName: Full=Tubulin beta-7 chain; AltName: Full=Tubulin beta 4'	TUBB	8	1.046	0.985	0.942	-0.087	0.034
211797	glyceraldehyde-3-phosphate dehydrogenase	GAPDH	9	0.824	1.032	1.252	0.325	0.034
1628381	glyceraldehyde-3-phosphate dehydrogenase	H2AFJ	9	0.824	1.032	1.252	0.325	0.034
63401	unnamed protein product, partial	GAPDH	4	0.839	1.133	1.350	0.433	0.036
28911960	heart fatty acid-binding protein, partial	FABP3	2	1.047	1.535	1.466	0.552	0.037
1016080546	vimentin	VIM	8	1.034	0.686	0.663	-0.592	0.037
53127891	hypothetical protein RCJMB04_4e21	SLC25A3	2	1.006	0.569	0.565	-0.823	0.038
971380098	heterogeneous nuclear ribonucleoproteins A2/B1 isoform X1	HNRNPA2B1	2	1.066	0.927	0.870	-0.202	0.039
1777308	connectin/titin, partial	TTN	2	1.353	0.792	0.585	-0.774	0.039
381140392	glyceraldehyde-3-phosphate dehydrogenase, partial	GAPDH	2	0.758	0.837	1.104	0.143	0.039
57530355	malate dehydrogenase, cytoplasmic isoform MDH1	MDH1	3	0.807	1.033	1.280	0.356	0.040
212811	beta-tropomyosin	TPM2	3	0.965	0.918	0.951	-0.072	0.040
971436767	tropomyosin alpha-4 chain isoform X4	TPM4	3	0.965	0.918	0.951	-0.072	0.040
833608	collagen a2, partial	COL1A2	2	0.935	0.600	0.642	-0.640	0.040
300630016	unnamed protein product	HK1	4	1.008	0.884	0.877	-0.189	0.041
211607	alpha-2 type I collagen, partial	COL1A2	4	0.909	0.571	0.628	-0.671	0.042
45382029	annexin A6	ANXA6	5	1.085	0.892	0.822	-0.283	0.042
50762391	fructose-1,6-bisphosphatase isozyme 2	FBP2	3	0.858	0.965	1.125	0.170	0.045
263505112	RecName: Full=Peroxiredoxin-1	PRDX1	2	1.067	0.933	0.874	-0.194	0.045
53133714	hypothetical protein RCJMB04_19j12	OGHD	5	0.888	1.128	1.270	0.345	0.046
409191	aldolase A, partial	ALDOA	2	1.022	1.092	1.068	0.096	0.047
1390105509	protein ADP-ribosylarginine hydrolase isoform X1	ADPRS	3	0.916	1.027	1.121	0.165	0.047
1390105511	protein ADP-ribosylarginine hydrolase isoform X2	ADPRS	3	0.916	1.027	1.121	0.165	0.047
1390086457	glycogen phosphorylase, muscle form-like	PYGL	6	1.067	0.951	0.891	-0.166	0.047
971401047	2-oxoglutarate dehydrogenase-like, mitochondrial isoform X1	OGDHL	2	0.888	1.090	1.227	0.296	0.050
261490820	peptidyl-prolyl cis-trans isomerase A	PPIA	4	1.047	1.211	1.157	0.210	0.050

Table 8.2 Significant proteins (p<0.05) of CTS diet at T12h vs CTL diet at T12h in muscle samples

List of significant protein with differences in abundance between groups associated to unique genes with the median in CTS and CTL diets (relative to internal standards), fc, Log fc and p-value. Proteins are listed, in order starting from the lowest in *p*. Proteins listed in order of increasing *p*.

Proteomics study 2 on liver: effects of CMB diet at T12h post LPS challenge

Comparing CTL vs CMB, 1373 proteins belonging to set criteria (2 unique peptides and 5% FDR) were identified. Among these, 59 proteins were significantly modulated by the CMB diet (22 higher abundances and 37 lower abundances), with 23 of them belonged to unique genes (12 higher abundances and 11 lower abundances) (Table 8.3).

Accession ID	Description	Gene name	Unique peptides	Median CTL	Median CTS	fc	Log fc	<i>p</i>
2687360	sulfotransferase	LOC395933	3	1.063	0.888	0.835	-0.26	0.003
363743802	thimet oligopeptidase	THOP1	2	1.033	0.899	0.87	-0.2	0.004
513165204	von Willebrand factor 8	VWA8	5	0.983	1.0815	1.1	0.137	0.006
1390080541	fatty aldehyde dehydrogenase	ALDH3A2	4	0.945	1.046	1.107	0.146	0.009
971393589	UDP-glucuronosyltransferase 2A2	UGT2A1	2	0.705	0.851	1.206	0.271	0.01
117258	Cytochrome P450 2H2	CYP2C23b	6	0.852	0.979	1.149	0.2	0.015
478247043	NADH dehydrogenase	NDUFB6	3	1.062	0.8	0.753	-0.409	0.016
3913805	Solute carrier	SLC2A2	4	0.988	1.071	1.084	0.116	0.017
118082784	ATP-dependent RNA helicase DDX17	DDX17	4	1.046	0.993	0.949	-0.075	0.018
118084650	propionyl-CoA carboxylase	PCCA	2	1.058	0.925	0.874	-0.194	0.019
48479076	ribosomal protein S13	RPS13	4	0.892	0.993	1.113	0.155	0.019
971424105	peroxisomal acyl-coenzyme A oxidase	ACOX1	9	1.062	1.007	0.948	-0.077	0.022
971445900	delta(3,5)-Delta(2,4)-dienoyl-CoA isomerase	ECH1	7	0.956	1.021	1.068	0.095	0.025
212811	beta-tropomyosin	TPM2	3	0.952	1.065	1.119	0.162	0.025
211827	Heat shock protein 70	HSPA5	9	1.053	0.999	0.949	-0.076	0.026
971422596	spectrin	SPTAN1	13	1.044	0.981	0.94	-0.09	0.033
50754810	catenin	CTNNA1	3	1.06	1.019	0.961	-0.057	0.035
971420215	peroxisomal 2,4-dienoyl-CoA reductase	DECR2	3	0.972	0.9925	1.021	0.029	0.038
54036699	actin	ACTC1	3	0.888	1.076	1.212	0.277	0.039
971402148	actin	ACTA2	3	0.888	1.076	1.212	0.277	0.039
1334744	spectrin	SPTAN1	11	1.045	0.996	0.953	-0.069	0.04
381342486	40S ribosomal protein S10	RPS10	2	0.973	1.0845	1.115	0.157	0.042
513204300	6-phosphofructo-2-kinase/fructose-2,6-bisphosphatase 4	LOC100859653	3	1.036	0.904	0.873	-0.197	0.046

Table 8.3 Significant proteins ($p < 0.05$) of CTL diet at T12h vs CMB diet at T12h in liver samples

List of significant protein with differences in abundance between groups associated to unique genes with the median in CMB and CTL diets (relative to internal standards), fc, Log fc and *p*-value. Proteins are listed, in order starting from the lowest in *p*. Proteins listed in order of increasing *p*.

Proteomics study 2 on muscle: effects of CMB diet at T12h post LPS challenge

In CMB vs CTL diet, from the 671 proteins belonging to set criteria (2 unique peptides and 5% FDR), 15 proteins were identified to be significantly different in their abundance with 9 of them (2 upregulated and 7 downregulated by CMB diet) being related to unique genes (Table 8.4).

Accession ID	Description	Gene name	Unique peptides	Median CTL	Median CTS	fc	Log fc	<i>p</i>
971390685	trifunctional enzyme subunit alpha, mitochondrial isoform X1	HADHA	3	1.155	0.899	0.779	-0.361	0.001
45382929	sarcoplasmic/endoplasmic reticulum calcium ATPase 1	ATP2A1	11	1.088	0.953	0.876	-0.191	0.013
68566062	Tudor-interacting repair regulator protein	NUDT16L1	4	1.155	1.045	0.905	-0.144	0.035
408498	globin	HBBA	2	0.97	1.065	1.098	0.135	0.035
212834	tubulin	TUBB1	3	1.155	0.987	0.855	-0.227	0.036
513162756	ATP synthase	ATP5O	2	0.953	1.145	1.201	0.265	0.038
45383808	60S ribosomal protein L6	RPL6	3	1.056	0.902	0.854	-0.227	0.048
999976	Triosephosphate Isomerase	TPI1	4	1.02	0.844	0.827	-0.273	0.049

Table 8.4 Significant proteins ($p < 0.05$) of CMB diet at T12h vs CTL diet at T12h in muscle samples

List of significant protein with differences in abundance between groups associated to unique genes with the median in CMB and CTL diets (relative to internal standards), fc, Log fc and p-value. Proteins are listed, in order starting from the lowest in *p*. Proteins listed in order of increasing *p*.

Appendix C- Metabolomics

Pooled study on plasma: LPS effect

A total of 6362 identified and annotated metabolites were detected in the plasma pooled study. Following processing the peaks annotated/identified based on mass and mass/retention time, 90 unique compounds matched the known standards (identified and identified+fragments metabolites). In the evaluation of LPS challenge, all pairwise comparison was considered as follow:

In CTL T0h vs CTL T12h, 72 identified and 1034 annotated metabolites were found significantly modulated by LPS challenge.

In CTL T0h vs CTL T24h, 23 identified and 594 annotated metabolites were found differentially expressed comparing the two groups.

In CTL T0h vs CTL T48h, 16 identified and 559 annotated metabolites displayed differences between the two time points.

After peak and isoforms evaluation, 35 identified metabolites were found significantly different at CTL T12 compared to T0h while 12 identified metabolites were found significantly different in CTL T24h and 48h compared to T0h (Tables 8.5,8.6,8.7).

CTL T0h vs CTL T12h

Peak id	Metabolite	Log FC	<i>p</i>	Adjusted <i>p</i>	Peak intensity T0h	Peak intensity T12h	Identification
1	Betaine	-1.01	0.0000	0.0000	2546708096	1264838080	identified+fragment
202	L-Asparagine	-1.10	0.0000	0.0000	12660841	5889615	identified+fragment
479	N-acetyl-L-glutamate	-0.86	0.0000	0.0000	186614	102782	identified
1163	sn-glycero-3-Phosphocholine	-1.83	0.0000	0.0000	242818	68130	identified
3715	Orotate	-1.57	0.0000	0.0000	183524	62002	identified
4	L-Proline	-0.63	0.0000	0.0001	554959904	359044224	identified
76	L-Methionine	-0.86	0.0000	0.0001	45433854	25067849	identified+fragment
2108	citrate	-0.65	0.0000	0.0001	44782416	28614479	identified+fragment
2219	L-Serine	-0.56	0.0000	0.0001	13248853	8955985	identified+fragment
10	L-Glutamine	-0.53	0.0000	0.0002	488861984	337516832	identified+fragment
2803	Uridine	1.18	0.0000	0.0002	528202	1198730	identified
2582	D-Galacturonate	-0.48	0.0000	0.0004	2552868	1832544	identified+fragment
2090	(R)-Lactate	-0.55	0.0001	0.0005	60350562	41150424	identified
819	Cytidine	0.82	0.0001	0.0006	535484	944130	identified+fragment
85	L-Lysine	1.01	0.0001	0.0007	12259060	24746948	identified+fragment
268	L-Cystine	-0.51	0.0001	0.0007	1039434	729986	identified+fragment
167	L-Tyrosine	-0.65	0.0001	0.0008	13761065	8750022	identified+fragment
362	O-Acetylcarnitine	-0.84	0.0001	0.0009	5537363	3092390	identified
2110	(S)-Malate	-0.70	0.0002	0.0012	33639641	20645189	identified+fragment
25	L-Arginine	-0.45	0.0002	0.0017	113309352	82720822	identified+fragment
2478	cis-Aconitate	-0.55	0.0002	0.0017	4130264	2817939	identified
2669	D-Ribose	-0.93	0.0003	0.0019	1412973	741530	identified
1166	L-Cystathionine	-0.66	0.0004	0.0025	357445	225889	identified+fragment
79	L-Leucine	-0.54	0.0004	0.0028	37091570	25462822	identified+fragment
3902	2-Oxoglutarate	-0.66	0.0005	0.0032	87056	55145	identified
3041	Malonate	-0.53	0.0007	0.0046	834089	576851	identified
98	L-Valine	-0.43	0.0009	0.0055	30523754	22589188	identified+fragment
3736	allantoin	-0.71	0.001	0.0059	125139	76700	identified
347	Adenine	-0.55	0.0017	0.0094	330205	225657	identified+fragment
2872	D-Galactarate	-0.45	0.0022	0.0113	169774	124144	identified

2866	2-Methylcitrate	-0.52	0.0023	0.0119	236835	165201	identified
1703	L-Kynurenine	-0.76	0.0029	0.0144	103970	61395	identified
2623	L-Aspartate	-1.39	0.0029	0.0144	815828	312041	identified
4080	4-Coumarate	-0.64	0.0052	0.024	75412	48309	Identified
562	N-Acetylglutamine	-0.53	0.0068	0.03	1714733	1189113	Identified

Table 8.5 Significant metabolites in CTL T0h vs CTL T12h in plasma samples

List of the first 30 significant identified metabolites ($p < 0.05$) with the relative Log fc, p , adjusted p and identification. Metabolites listed in the order of increasing adjusted p .

CTL T0h vs CTL T24h

Table 8.6 Significant metabolites in CTL T0h vs CTL T24h in plasma samples

Peak id	metabolite	Log FC	p	Adjusted p	Peak intensity T0h	Peak intensity T24h	Identification
479	N-acetyl-L-glutamate	-0.86	0.0000	0.0000	186614	102546	Identified
2582	D-Galacturonate	-0.60	0.0000	0.0000	2552868	1689535	identified+fragment
167	L-Tyrosine	-0.84	0.0000	0.0001	13761065	7678238	identified+fragment
66	L-homoserine/L-Threonine	-0.47	0.0001	0.0008	51918117	37569749	identified+fragment
202	L-Asparagine	-0.57	0.0001	0.0008	12660841	8502293	identified+fragment
3521	L-Citrulline	-0.61	0.0002	0.0022	240291	157353	Identified
311	L-Glutamate/O-Acetyl-L-serine	-0.46	0.0009	0.0088	7673971	5597139	Identified
1	Betaine	-0.46	0.0019	0.0173	2546708096	1849570336	identified+fragment
2613	Pyruvate	-0.32	0.0021	0.0186	2277300	1818044	Identified
98	L-Valine	-0.42	0.0022	0.0188	30523754	22760132	identified+fragment
3165	thymine	2.43	0.0022	0.0192	81685	440065	Identified
3715	Orotate	-0.71	0.0056	0.0412	183524	112161	Identified

List of significant identified metabolites ($p < 0.05$) with the relative Log fc, p , adjusted p and identification. Metabolites listed in the order of increasing adjusted p .

CTL T0h vs CTL T48h

Peak id	metabolite	Log FC	<i>p</i>	Adjusted <i>p</i>	Peak intensity T0h	Peak intensity T48h	Identification
479	N-acetyl-L-glutamate	-0.78	0.0000	0.0000	186614	108953	identified
1064	Adenosine	-1.83	0.0000	0.0000	393389	110772	identified+fragment
2513	D-glucose/D-Fructose	-0.29	0.0000	0.0001	4074804	3337556	identified
3521	L-Citrulline	-0.70	0.0000	0.0006	240291	148084	identified
2582	D-Galacturonate	-0.42	0.0002	0.0025	2552868	1902116	identified+fragment
202	L-Asparagine	-0.48	0.0008	0.008	12660841	9072486	identified+fragment
268	L-Cystine	0.39	0.0012	0.0121	1039434	1360700	identified+fragment
1163	sn-glycero-3-Phosphocholine	0.72	0.0014	0.0131	242818	398726	identified
1109	Choline phosphate	1.31	0.0023	0.0204	125032	310486	identified
66	L-homoserine/L-Threonine	-0.33	0.0041	0.0345	51918117	41164654	identified+fragment
3627	2-oxobutanoate	-0.42	0.0064	0.0489	168362	125477	identified
3930	Phenylpyruvate	-0.87	0.0065	0.0498	72225	39391	identified

Table 8.7 Significant metabolites in CTL T0h vs CTL T48h in plasma samples

List of significant identified metabolites ($p < 0.05$) with the relative Log fc, p , adjusted p and identification. Metabolites listed in the order of increasing adjusted p .

Pooled study on plasma: dietary effect

CTS effect

In the evaluation of dietary treatments (CTS and CMB diet vs CTL diet), the 8 group-wise comparisons identified significant changes; peaks with an adjusted $p < 0.05$ were considered significant. Each pairwise comparison was studied separately: significant differences were found in CTS diet at most of the time points pre and post challenge while no differences were discovered comparing CMB vs CTL diet.

In CTS vs CTL diet pre challenge (T0h), 3 identified compounds were found significantly decreased by CTS diet (adjusted $p < 0.05$): adenosine, 2-methylcitrate and R)-2-Hydroxyglutarate. Other 310 annotated peaks were significantly changing.

In CTS vs CTL diet at T12h post challenge, no statistically significant identified compounds have been identified but 201 annotated peaks were significantly changing comparing the two groups.

In CTS vs CTL diet at T24h post challenge, 33 annotated peaks significantly displayed differences comparing the two groups.

In CTS vs CTL diet at T48h post challenge, adenosine was the only identified metabolite to show higher abundance in CTS (adjusted $p < 0.05$). Other 108 annotated peaks significantly displayed differences comparing the two groups.

The list of annotated metabolites was studied and filtered based on peak and isoform's evaluation; 76 metabolites were found significantly different at T0h, 47 metabolites at T12h and 45 metabolites at T48h in CTS vs CTL diet (see Tables 8.8,8.9, 8.10). Most of these metabolites belong to amino acids metabolism and were found to be significantly decreased by CTS diet at T0h, T12h and T48h.

CTL T0h vs CTS T0h

Peak Id	Metabolite	Log FC	<i>p</i>	Adjusted <i>p</i>	Peak intensity CTL	Peak intensity CTS	Identification
37	L-Acetopine	-2.36	0.000	0.000	84710226	16496722	annotated
114	N-Acetyl-L-glutamate 5-semialdehyde	-2.21	0.000	0.000	23794150	5159202	annotated
116	L-cis-Cyclo(aspartylphenylalanyl)	-2.24	0.000	0.000	636727	135191	annotated
119	Methyl hippurate	-1.31	0.000	0.000	393243	158684	annotated
149	Tromethamine	1.25	0.000	0.000	1081619	2567848	annotated+fragment
156	Alanyl-Aspartate	-2.35	0.000	0.000	16143067	3165593	annotated
157	Isoleucyl-Serine	-2.44	0.000	0.000	2571459	473803	annotated
160	Histidiny-Aspartate	-2.12	0.000	0.000	124296	28676	annotated
161	Thionazin	-2.15	0.000	0.000	105269	23685	annotated
165	Hydroxyprolyl-Proline	1.33	0.000	0.000	2596837	6515856	annotated
338	L-gamma-glutamyl-L-leucine	-2.14	0.000	0.000	1162247	262942	annotated
391	Glutaryl-glycine	-2.19	0.000	0.000	4777769	1044222	annotated
392	Lysyl-Asparagine	-2.32	0.000	0.000	750761	149884	annotated
395	Mimosine	-3.39	0.000	0.000	88656	8447	annotated
414	Carboxy-ibuprofen	-0.78	0.000	0.000	2238386	1300758	annotated
449	Glycylprolylhydroxyproline	2.43	0.000	0.000	245591	1322838	annotated
458	L-1,2,3,4-Tetrahydro-beta-carboline-3-carboxylic acid	-2.45	0.000	0.000	140195	25610	annotated
506	N6-Acetyl-5S-hydroxy-L-lysine	-0.98	0.000	0.000	1412613	714404	annotated
520	Vinylacetyl-glycine	-2.39	0.000	0.000	2936840	559310	annotated
524	Didodecyl thiobispropanoate	-0.60	0.000	0.000	1128722	742727	annotated
638	Alpha-CEHC	-0.73	0.000	0.000	833391	503884	annotated
682	Glycyl-Aspartate	-1.05	0.000	0.000	1525175	736913	annotated
696	Alanyl-Proline	-2.72	0.000	0.000	1700329	258735	annotated
932	Methyl benzoate	-1.21	0.000	0.000	90848	39344	annotated
1075	Tris(2-chloroethyl) phosphate	-0.44	0.000	0.000	236966	175269	annotated+fragment
1077	alpha,alpha'-Trehalose 6-mycolate	-1.40	0.000	0.000	390865	148056	annotated
1122	S-4-Hydroxymephenytoin	-2.22	0.000	0.000	494738	106515	annotated
1123	Ornaline	-2.22	0.000	0.000	494738	106515	annotated

1839	2-aminomuconic acid semialdehyde	0.97	0.000	0.000	65093	127379	annotated
1842	N-(1-Deoxy-1-fructosyl) histidine	-0.54	0.000	0.000	121739	83864	annotated

Table 8.8 Significant metabolites in CTL T0h vs CTS T0h in plasma samples

List of first 30 significant annotated and identified metabolites ($p < 0.05$) with the relative Log fc, p , adjusted p and identification. Metabolites listed in the order of increasing adjusted p -value

CTL T12h vs CTS T12h

Peak id	Metabolite	Log FC	p	Adjusted p	Peak intensity CTL	Peak intensity CTS	Identification
37	L-Acetopine	2.02	0.0000	0.0000	2587816	10488640	annotated
114	N-Acetyl-L-glutamate 5-semialdehyde	2.24	0.0000	0.0000	587078	2781535	annotated
116	L-cis-Cyclo(aspartylphenylalanyl)	1.83	0.0000	0.0000	33460	118670	annotated
156	Alanyl-Aspartate	2.50	0.0000	0.0000	307270	1737659	annotated
157	Isoleucyl-Serine	2.07	0.0000	0.0000	99424	418877	annotated
338	L-gamma-glutamyl-L-leucine	2.08	0.0000	0.0000	48665	205672	annotated
391	Glutaryl-glycine	2.42	0.0000	0.0000	179226	959769	annotated
506	N6-Acetyl-5S-hydroxy-L-lysine	2.47	0.0000	0.0000	264942	1467484	annotated
682	Glycyl-Aspartate	1.98	0.0000	0.0000	36386	143612	annotated
1122	S-4-Hydroxymephenytoin	3.09	0.0000	0.0000	9880	84241	annotated
2152	L-Homocysteic acid	2.77	0.0000	0.0000	508550	3464857	annotated
2404	5-Hydroxyindoleacetate	2.27	0.0000	0.0000	242614	1166425	annotated
2417	1-(2,6,6-Trimethyl-1-cyclohexen-1-yl)-1-penten-3-one	-0.88	0.0000	0.0000	932637	505559	annotated
2530	2-Oxoglutaminate	2.38	0.0000	0.0000	112260	583200	annotated
2565	L-alpha-Amino-5-oxo-2(5H)-isoxazolepropanoic acid	2.34	0.0000	0.0000	70573	356544	annotated
2622	2-Oxosuccinamate	2.49	0.0000	0.0000	75478	424140	annotated

2641	Tiglylglycine	1.81	0.0000	0.0000	92831	325300	annotated
3212	3,6,8-Trimethylallantoin	2.15	0.0000	0.0000	15269	67802	annotated
3231	4,5-Dihydroorotic acid	4.56	0.0000	0.0000	2242	52911	annotated
3433	PS(15:0/22:2(13Z,16Z))	2.42	0.0000	0.0000	9752	52070	annotated
3536	alpha-Valerenol	0.76	0.0000	0.0000	344927	72787	annotated
3585	Aspartyl-Proline	2.80	0.0000	0.0000	247743	145594	annotated
3599	Hydroxypropyl-Hydroxyproline	1.36	0.0000	0.0000	137205	13340	annotated
3653	1-Pyrenylsulfate	1.99	0.0000	0.0000	175597	52297	annotated
4212	Neodunol	1.82	0.0000	0.0000	95075	62129	annotated
3764	1-Naphthalenesulfonic acid	1.32	0.0000	0.0000	128528	94643	annotated
4012	3-(2-Hydroxy-4-methylphenyl)-2-butanone	0.62	0.0000	0.0000	121979	48197	annotated
2417	1-(2,6,6-Trimethyl-1-cyclohexen-1-yl)-1-penten-3-one	0.71	0.0000	0.0000	5762024	1170746	annotated
1004	N-Acetyl-L-tyrosine	1.33	0.0000	0.0000	20481	11597	annotated
1672	delta-1-Pyrroline-5-carboxylate	0.55	0.0000	0.0000	135747	263841	annotated

Table 8.9 Significant metabolites in CTL T12h vs CTS T12h in plasma samples

List of first 30 significant annotated and identified metabolites ($p < 0.05$) with the relative Log fc, p , adjusted p and identification. Metabolites listed in the order of increasing adjusted p

CTL T48h vs CTS T48h

Peak Id	Metabolite	Log FC	<i>p</i>	Adjusted <i>p</i>	Peak intensity CTL	Peak intensity CTS	Identification
41	Fluocinolone	-0.46	0.000	0.000	869531	630175	annotated+fragment
149	Tromethamine	-1.55	0.000	0.000	15299739	5234545	annotated
150	Gibberellin A61	-1.81	0.000	0.000	102702	29358	annotated
213	Isobutyryl-L-carnitine	-1.78	0.000	0.000	156391	45591	annotated
391	Glutaryl glycine	0.46	0.000	0.000	7684	10605	annotated
414	Carboxy-ibuprofen	-0.54	0.000	0.000	4259777	2923495	annotated+fragment
635	Didodecyl thiobispropanoate	-0.60	0.000	0.000	1908947	1263102	annotated
638	Alpha-CEHC	-0.68	0.000	0.000	1107648	690977	annotated
753	Homoarecoline	-1.08	0.000	0.000	521915	247387	annotated
1064	Adenosine	1.74	0.000	0.000	110772	368969	identified+fragment
1065	Methyl thiophene-2-carboxylate	-0.63	0.000	0.000	506379	328315	annotated
1380	Deoxyguanidinoproclavaminic acid	-8.47	0.000	0.000	35374	0	annotated
1532	Isoetharine	-0.63	0.000	0.000	166215	107679	annotated
2095	ethyl tetradecanoate	-0.52	0.000	0.000	51482368	35946250	annotated
2312	3-keto-n-caproic acid	0.63	0.000	0.000	5538908	8545676	annotated
2411	hexyl propionate	-1.38	0.000	0.000	3636744	1398427	annotated
2417	1-(2,6,6-Trimethyl-1-cyclohexen-1-yl)-1-penten-3-one	-0.75	0.000	0.000	5026923	2984306	annotated
2419	Glycerol tributanoate	-0.62	0.000	0.001	89227	58099	annotated
2453	Ethyl (±)-3-methylpentanoate	-1.18	0.000	0.001	2841454	1254823	annotated
2454	3R-hydroxy-decanoic acid	-1.17	0.000	0.001	91707	40895	annotated
2455	Salicylaldehyde	-1.07	0.000	0.001	3841396	1826559	annotated
2456	Menthyl ethylene glycol carbonate	-1.70	0.000	0.001	683332	210867	annotated
2457	Ethyl tiglate	-0.66	0.000	0.001	212879	135109	annotated
2463	Phenylacetic acid	-2.06	0.000	0.001	3002442	718553	annotated
2800	Methyl benzoate	-0.83	0.000	0.002	1380027	774936	annotated
2981	2-Methylpropyl propionate	-0.67	0.000	0.002	808767	506810	annotated
2982	Dodecanedioic acid	-1.23	0.000	0.005	211182	90087	annotated
3000	11-docosenoic acid	-1.96	0.000	0.005	707524	182441	annotated

Table 8.10 Significant metabolites in CTL T48h vs CTS T48h in plasma samples

List of first 30 significant annotated and identified metabolites ($p < 0.05$) with the relative Log fc, *p*, adjusted *p* and identification. Metabolites listed in order of increasing adjusted *p*.

CMB effect

In CMB vs CTL diets no identified metabolites have been identified at all time points but just few annotated metabolites showed significant differences among the dietary groups.

In CMB vs CTL diet pre challenge (T0h), 2 annotated metabolites were significantly changing comparing the two groups.

In CMB vs CTL diet at T12h post challenge, 4 annotated peaks were significantly changing comparing the two groups.

In CMB vs CTL diet at T24h post challenge, 11 annotated metabolites displayed differences comparing the two groups.

In CMB vs CTL diet at T48h post challenge, 9 annotated metabolites significantly displayed differences comparing the two groups.

The list of annotated metabolites was studied and filtered based on peak and isoform's evaluation; 1 metabolite were found significantly different at T0h, 2 metabolites at T12h and 5 metabolites at T48h in CTS vs CTL diet (Table 8.11). Most of these metabolites belong to amino acids metabolism and were found to be significantly decreased by CTS diet at T0h, T12h and T48h

CTL T0h vs CMB T0h

Peak Id	Metabolite	Log FC	<i>p</i>	Adjusted <i>p</i>	Peak intensity CTL	Peak intensity CMB	Identification
4032	PG(18:1(9Z)/18:1(11Z))	2.73	0.000	0.000	33221	0	annotated

CTL T12h vs CMB T12h

Peak Id	Metabolite	Log FC	<i>p</i>	Adjusted <i>p</i>	Peak intensity CTL	Peak intensity CMB	Identification
1244	5-Methylcytidine	-1.95	0.000	0.000	0	19301	annotated
1605	L-2-Amino-3-(1-pyrazolyl)propanoic acid	-3.14	0.000	0.000	0	48691	annotated

CTL T48h vs CMB T48h

Peak Id	Metabolite	Log FC	<i>p</i>	Adjusted <i>p</i>	Peak intensity CTL	Peak intensity CMB	Identification
372	PE(24:0/15:0)	1.7	0.000	0.000	7039877	0	annotated
506	N6-Acetyl-5S-hydroxy-L-lysine;Bicine	-2.4	0.000	0.000	0	12671	annotated
1214	Lauroyl diethanolamide	-1.5	0.000	0.000	218967	338122	annotated
156	Alanyl-Aspartate	1.95	0.000	0.000	9390	0	annotated
1460	L-a-glutamyl-L-Lysine	2.5	0.000	0.000	141745	0	annotated

Table 8.11 Significant metabolites in CTL T0,12,24,48h vs CMB T0,12,24,48h in plasma samples

List of first 30 significant annotated and identified metabolites ($p < 0.05$) with the relative Log fc, p , adjusted p and identification. Metabolites listed in order of increasing adjusted p in each comparison.

Pooled study on liver

CMB effect

In CMB vs CTL diets no identified metabolites have been identified at all time points but just few annotated metabolites showed significant differences among the dietary groups.

In CMB vs CTL diet pre challenge (T0h), 32 annotated metabolites were significantly changing comparing the two groups.

In CMB vs CTL diet at T12h post challenge, 102 annotated peaks were significantly changing comparing the two groups.

In CMB vs CTL diet at T24h post challenge, 18 annotated metabolites displayed differences comparing the two groups.

In CMB vs CTL diet at T48h post challenge, 23 annotated metabolites significantly displayed differences comparing the two groups.

The list of annotated metabolites was studied and filtered based on peak and isoform's evaluation; 6 metabolites were found significantly different at T0h, 18 metabolites at T12h and 6 metabolites at T48h in CTS vs CTL diet (Table 8.12). Most of these metabolites belong to amino acids metabolism and were found to be significantly decreased by CTS diet at T0h, T12h and T48h

CTL T0h vs CMB T0h

Peak Id	Metabolite	Log FC	<i>p</i>	Adjusted <i>p</i>	Peak intensity CTL	Peak intensity CMB	Identification
4946	Dihydro-4-mercapto-3(2H)-furanone	-1.29	0.000	0.000	147392	0	annotated
518	PI(18:1(9Z)/18:2(9Z,12Z))	3.19	0.000	0.000	0	10974579	annotated
839	Cohibin C	5.31	0.000	0.000	1047863	308186	annotated
2399	PC(20:5(5Z,8Z,11Z,14Z,17Z)/0:0)	2.28	0.000	0.000	0	76442	annotated
805	PE(20:0/14:1(9Z))	-4.62	0.000	0.000	0	73159	annotated
2521	Isogingerenone B	-2.34	0.000	0.000	0	34723	annotated

CTL T12h vs CMB T12h

Peak Id	Metabolite	Log FC	<i>p</i>	Adjusted <i>p</i>	Peak intensity CTL	Peak intensity CMB	Identification
3560	Vorinostat	-3.4	0.000	0.000	0	19301	annotated
2804	Pyrophosphate	-2.73	0.000	0.000	1556904	246005	identified
475	Dimorphecolic acid	-3.12	0.000	0.000	43348	0	annotated
5351	Monuron	-3.12	0.000	0.000	43381	0	annotated
4282	Thiophene	0.76	0.000	0.000	222001	399621	annotated
3400	Astilbin	-2.68	0.000	0.000	32568	0	annotated
2811	Dihydro-4,6-dimethyl-2-(1-methylethyl)	-4.66	0.000	0.000	136741	0	annotated
3388	Fosamine	-0.81	0.000	0.000	3902257	2264809	annotated
5008	4-Hydroxychalcone	-1.18	0.000	0.000	166997	81489	annotated
3603	Desmedipham	-1.35	0.000	0.000	170140	67286	annotated
2813	SB 206553	-3.94	0.000	0.000	82050	0	annotated
4158	3-oxo-tetradecanoic acid	-2.14	0.000	0.000	22507	0	annotated
2764	2-Methylcitric acid	-2.95	0.000	0.000	38570	0	annotated
2814	Enalaprilate	-1.34	0.000	0.000	215033	88347	annotated
5376	N,N'-Diacetylhydrazine	-2.13	0.000	0.000	22253	0	annotated
3005	(2R)-2-Hydroxy-3-(phosphonatoxy)propanoate	-2.40	0.000	0.001	4341725	848568	identified
1794	Isoputranine	-2.74	0.000	0.001	33309	0	annotated
4148	PE(18:3(6Z,9Z,12Z)/0:0)	-2.04	0.000	0.001	20628	0	annotated

CTL T24h vs CMB T24h

Peak Id	Metabolite	Log FC	<i>p</i>	Adjusted <i>p</i>	Peak intensity CTL	Peak intensity CMB	Identification
4575	N-Acetyldehydroanonaine	1.7	0.000	0.000	110141	268138	annotated
3861	PG(P-18:0/18:4(6Z,9Z,12Z,15Z))	-2.4	0.000	0.000	73263	0	annotated
4518	Phenindione	-1.5	0.000	0.000	197947	0	annotated
479	PC(18:0/0:0)	1.95	0.000	0.000	24342	0	annotated
1814	Acetoxyacetone	-2.4	0.000	0.000	0	124931	annotated
3979	Styrene	-1.5	0.000	0.000	84886	386563	annotated

Table 8.12 Significant metabolites in CTL vs CMB diets at T0,12,24,48h in liver samples

List of significant annotated and identified metabolites ($p < 0.05$) with the relative Log fc, p , adjusted p and identification. Metabolites listed in order of increasing adjusted p in each comparison.

References

- Abbasi, H., Seidavi, A., Lui W., and Asadpour, L. 2015. 'Investigation on the Effect of Different Levels of Dried Sweet Orange (*Citrus Sinensis*) Pulp on Performance, Carcass Characteristics and Physiological and Biochemical Parameters in Broiler Chicken'. *Saudi Journal of Biological Sciences* 22 (2): 139–46. <https://doi.org/10.1016/j.sjbs.2014.09.006>.
- Abdallah, C., Dumas-Gaudot, E., Renaut, J., and Sergeant, K. 2012. 'Gel-Based and Gel-Free Quantitative Proteomics Approaches at a Glance'. *International Journal of Plant Genomics*: 1–17. <https://doi.org/10.1155/2012/494572>.
- Abu-Reidah, I. M., Arráez-Román, D., Quirantes-Piné, R., Fernández-Arroyo, S., Segura-Carretero, A., and Fernández-Gutiérrez, A. 2012. 'HPLC–ESI-Q-TOF-MS for a Comprehensive Characterization of Bioactive Phenolic Compounds in Cucumber Whole Fruit Extract'. *Food Research International* 46 (1): 108–17. <https://doi.org/10.1016/j.foodres.2011.11.026>.
- Adewole, D., and Akinyemi, F. 2021. 'Gut Microbiota Dynamics, Growth Performance, and Gut Morphology in Broiler Chickens Fed Diets Varying in Energy Density with or without Bacitracin Methylene Disalicylate (BMD)'. *Microorganisms* 9 (4): 787. <https://doi.org/10.3390/microorganisms9040787>.
- Afrouziyeh, M., Zukiwsky, N.M., Korver, D.R., and Zuidhof, M. J. 2022. 'Plasma Metabolomic Profiling Reveals Potential Onset of Lay Biomarkers in Broiler Breeders'. *Poultry Science* 101 (1): 101532. <https://doi.org/10.1016/j.psj.2021.101532>.
- Agatemor, U. M., Fred, O., and Nwodo, C. 2015. 'Anti-Inflammatory Activity of *Cucumis Sativus* L Anti-Inflammatory Activity of *Cucumis Sativus* L.', *British Journal of Pharmaceutical Research*. <https://doi.org/10.9734/BJPR/2015/19700>.
- Aggrey, S.E, Karnuah, B.A., Sebastian, B., and Anthony, N.B. 2010. 'Genetic Properties of Feed Efficiency Parameters in Meat-Type Chickens', *Genetics selection evolution* 1–5. <https://doi.org/10.1186/1297-9686-42-25>
- Agin, A., Heintz, D., Ruhland, E., Chao de la Barca, J.M., Zumsteg, J., Moal, V., Gauchez, A.S., and Namer, I.J. 2016. 'Metabolomics – an Overview. From Basic Principles to Potential Biomarkers'. *Médecine Nucléaire* 40 (1): 4–10. <https://doi.org/10.1016/j.mednuc.2015.12.006>.
- Ahmad, S.S., Khalid, M., Younis, K. 2019. 'Interaction study of dietary fibers (pectin and cellulose) with meat proteins using bioinformatics analysis: An In-Silico study, *LWT Food Science and Technology*, doi: <https://doi.org/10.1016/j.lwt.2019.108889>.
- Ajuwon, O. R., Oguntibeju, O. O., and Marnewick, J. L. 2014. 'Amelioration of lipopolysaccharide-induced liver injury by aqueous rooibos (*Aspalathus linearis*) extract via inhibition of pro-inflammatory cytokines and oxidative stress'. *BMC complementary and alternative medicine*, 14, 392. <https://doi.org/10.1186/1472-6882-14-392>
- Akbarian, A., A. Golian, A. Gilani, H. Kermanshahi, S. Zhaleh, A. Akhavan, S. De Smet, and J. Michiels. 2013. 'Effect of Feeding Citrus Peel Extracts on Growth Performance, Serum Components, and Intestinal Morphology of Broilers Exposed to High Ambient Temperature during the Finisher Phase'. *Livestock Science* 157 (2–3): 490–97. <https://doi.org/10.1016/j.livsci.2013.08.010>.
- Akiyama, T., Ishida, S., Nakagawa, H., Ogawara, S., Watanabe, N., Itoh, M., Shibuya, and Fukami, Y. 1987. 'Genistein, a Specific Inhibitor of Tyrosine-Specific Protein Kinases.' *Journal of Biological Chemistry* 262 (12): 5592–95. [https://doi.org/10.1016/S0021-9258\(18\)45614-1](https://doi.org/10.1016/S0021-9258(18)45614-1).

- Alagawany, M., Elnesr, S. S., Farag, M. R., Abd El-Hack, M. E., Barkat, R. A., Gabr, A. A., Foda, M. A., Noreldin, A. E., Khafaga, A. F., El-Sabrou, K., Elwan, H., Tiwari, R., Yattoo, M. I., Michalak, I., Di Cerbo, A. and Dhama, K. 2021. 'Potential role of important nutraceuticals in poultry performance and health - A comprehensive review'. *Research in veterinary science*, 137, 9–29. <https://doi.org/10.1016/j.rvsc.2021.04.009>
- Alçiçek, A., Bozkurt, M. and Çabuk, M. 2004. 'The Effect of a Mixture of Herbal Essential Oils, an Organic Acid or a Probiotic on Broiler Performance'. *South African Journal of Animal Science*, 7.
- Alders, R. G., Dumas, S. E., Rukambile, E., Magoke, G., Maulaga, W., Jong, J. and Costa, R. 2018. 'Family poultry: Multiple roles, systems, challenges, and options for sustainable contributions to household nutrition security through a planetary health lens'. *Maternal and child nutrition*, 14:3 <https://doi.org/10.1111/mcn.12668>
- Alexander, C., and Rietschel, E.T. 2001. 'Bacterial Lipopolysaccharides and Innate Immunity'. *Journal of Endotoxin Research* 7 (3): 167–202. <https://doi.org/10.1179/096805101101532675>.
- Aliprantis, A. O. 2000. 'The Apoptotic Signaling Pathway Activated by Toll-like Receptor-2'. *The EMBO Journal* 19 (13): 3325–36. <https://doi.org/10.1093/emboj/19.13.3325>.
- Almeida, A. M., Bassols, A., Bendixen, E., Bhide, M., Ceciliani, F., Cristobal, S., Eckersall, P. D., Hollung, K., Lisacek, F., Mazzucchelli, G., McLaughlin, M., Miller, I., Nally, J. E., Plowman, J., Renaut, J., Rodrigues, P., Roncada, P., Staric, J., and Turk, R. 2015. 'Animal an international journal of animal bioscience', 9(1), 1–17. <https://doi.org/10.1017/S1751731114002602>.
- Amit-Romach, E., Sklan, D., and Uni, Z. 2004. 'Microflora Ecology of the Chicken Intestine Using 16S Ribosomal DNA Primers'. *Poultry Science* 83 (7): 1093–98. <https://doi.org/10.1093/ps/83.7.1093>.
- Annett, C. B., Viste, J. R., Chirino-Trejo, M., Classen, H. L., Middleton, D. M., and Simko, E. 2002. 'Necrotic Enteritis: Effect of Barley, Wheat and Corn Diets on Proliferation of *Clostridium Perfringens* Type A'. *Avian Pathology* 31 (6): 598–601. <https://doi.org/10.1080/0307945021000024544>.
- Antonioli, L., Fornai, M., Blandizzi, C., Pacher, P., and Haskó, G. 2019. 'Adenosine Signaling and the immune system: when a lot could be too much'. *Immunology Letters*: 9–15. <https://doi.org/10.1016/j.imlet.2018.04.006>.
- Ao, T., Cantor, A. H., Pescatore, A.J., Ford, M.J., Pierce, J.L. and Dawson K.A. 2009. 'Effect of Enzyme Supplementation and Acidification of Diets on Nutrient Digestibility and Growth Performance of Broiler Chicks'. *Poultry Science* 88 (1): 111–17. <https://doi.org/10.3382/ps.2008-00191>.
- Arango Duque, G., and Descoteaux, A. 2014. 'Macrophage Cytokines: Involvement in Immunity and Infectious Diseases'. *Frontiers in Immunology*. <https://doi.org/10.3389/fimmu.2014.00491>.
- Ariyadi, B., Sudaryati, S., Harimurti, S., Wihandoyo, Sasongko, H., Habibi, M.F., and Rahayu, D. 2019. 'Effects of Feed Form on Small Intestine Histomorphology of Broilers'. *IOP Conference Series: Earth and Environmental Science* 387: 012047. <https://doi.org/10.1088/1755-1315/387/1/012047>.
- Aruwa, C. E., Pillay, C., Nyaga, N.N., and Sabiu, S. 2021. 'Poultry Gut Health – Microbiome Functions, Environmental Impacts, Microbiome Engineering and Advancements in Characterization Technologies'. *Journal of Animal Science and Biotechnology* 12 (1): 119. <https://doi.org/10.1186/s40104-021-00640-9>.
- Asai, Y., Bajotto, G., Yoshizato, H., Hamada, K., Higuchi, T., and Shimomura, Y. 2008. 'The Effects of Endotoxin on Plasma Free Amino Acid Concentrations in Rats'.

- Journal of Nutritional Science and Vitaminology 54 (6): 460–66. <https://doi.org/10.3177/jnsv.54.460>.
- Aslam, B., Basit, M., Nisar, M. A., Khurshid, M., and Rasool, M. H. 2017. ‘Proteomics: Technologies and Their Applications’. *Journal of Chromatographic Science* 55 (2): 182–96. <https://doi.org/10.1093/chromsci/bmw167>.
- Ávila, G., De Leonardis, D., Grilli, G., Lecchi, C., and Ceciliani, F. 2021. ‘Anti-Inflammatory Activity of Citrus Pectin on Chicken Monocytes’ Immune Response’. *Veterinary Immunology and Immunopathology* 237: 110269. <https://doi.org/10.1016/j.vetimm.2021.110269>.
- Bajad, S. U., Lu, W., Kimball, E. H., Yuan, J., Peterson, C. and Rabinowitz, J. D. 2006. ‘Separation and Quantitation of Water-Soluble Cellular Metabolites by Hydrophilic Interaction Chromatography-Tandem Mass Spectrometry’. *Journal of Chromatography A* 1125 (1): 76–88. <https://doi.org/10.1016/j.chroma.2006.05.019>.
- Bai, C. S., Hardy, R. W. and Hamidoghli, A. 2022. ‘Diet Analysis and Evaluation’. In *Fish Nutrition*, 709–43. Elsevier. <https://doi.org/10.1016/B978-0-12-819587-1.00010-0>.
- Baldassini, W. A., Bonilha, S. F. M., Branco, R. H., Vieira, J. C. S., Padilha, P. M. and Lanna, D. P. D. 2018. ‘Proteomic Investigation of Liver from Beef Cattle (*Bos Indicus*) Divergently Ranked on Residual Feed Intake’. *Molecular Biology Reports* 45 (6): 2765–73. <https://doi.org/10.1007/s11033-018-4341-2>.
- Ballou, A. L., Ali, R. A., Mendoza, M. A., Ellis, J. C., Hassan, H. M., Croom, W. J. and Koci, M. D. 2016. ‘Development of the Chick Microbiome: How Early Exposure Influences Future Microbial Diversity’. *Frontiers in Veterinary Science* 3. <https://doi.org/10.3389/fvets.2016.00002>.
- Barallobre-Barreiro, J., Chung Y. L., and Mayr, M. 2013. ‘Proteomics and Metabolomics for Mechanistic Insights and Biomarker Discovery in Cardiovascular Disease’. *Revista Española de Cardiología (English Edition)* 66 (8): 657–61. <https://doi.org/10.1016/j.rec.2013.04.009>.
- Barnes, D. M., Song, Z., Klasing, K. C. and Bottje, W. 2002. ‘Protein Metabolism during an Acute Phase Response in Chickens’. *Amino Acids* 22 (1): 15–26. <https://doi.org/10.1007/s726-002-8198-6>.
- Barondes, S. H., Douglas, N. W., Cooper, M. A., Gitt, S. and Leffler, H. 1994. ‘Structure and function of a large family of animal lectins’, *Journal of Biological Chemistry* 269:(33): 20807-20810.
- Belkaid, Y., and Harrison, O. J. 2017. ‘Homeostatic Immunity and the Microbiota’. *Immunity* 46 (4): 562–76. <https://doi.org/10.1016/j.immuni.2017.04.008>.
- Bernardini, C., Zannoni, A., Bertocchi, M., Tubon, I., Fernandez, M. and Forni, M. 2018. ‘Water/Ethanol Extract of *Cucumis Sativus* L. Fruit Attenuates Lipopolysaccharide-Induced Inflammatory Response in Endothelial Cells’. *BMC Complementary and Alternative Medicine* 18 (1): 1–9. <https://doi.org/10.1186/s12906-018-2254-1>.
- Bertani, B. and Ruiz, N. 2018. ‘Function and Biogenesis of Lipopolysaccharides’. Edited by James M. Slauch. *EcoSal Plus* 8 (1). <https://doi.org/10.1128/ecosalplus.ESP-0001-2018>.
- Besten, G. D., Eunen, K., Groen, A. K., Venema, K., Reijngoud, D. J. and Bakker M. 2013. ‘The Role of Short-Chain Fatty Acids in the Interplay between Diet, Gut Microbiota, and Host Energy Metabolism’. *Journal of Lipid Research* 54 (9): 2325–40. <https://doi.org/10.1194/jlr.R036012>.
- Bevilacqua, A., Corbo A. R., and Sinigaglia, M. 2010. ‘In Vitro Evaluation of the Antimicrobial Activity of Eugenol, Limonene, and Citrus Extract against Bacteria and Yeasts, Representative of the Spoiling Microflora of Fruit Juices’. *Journal of Food Protection* 73 (5): 888–94. <https://doi.org/10.4315/0362-028X-73.5.888>.

- Bicer, S., Reiser, P. J., Ching, S. and Quan, N. 2009. 'Induction of Muscle Weakness by Local Inflammation: An Experimental Animal Model'. *Inflammation Research* 58 (4): 175–83. <https://doi.org/10.1007/s00011-008-8093-7>.
- Biddle, A., Stewart, L., Blanchard, J. and Leschine, S. 2013. 'Untangling the Genetic Basis of Fibrolytic Specialization by Lachnospiraceae and Ruminococcaceae in Diverse Gut Communities'. *Diversity* 5 (3): 627–40. <https://doi.org/10.3390/d5030627>.
- Bilić, P., Kuleš, J., Galan, A., Gomes de Pontes, L., Guillemin, N., Horvatić, A., Sabes, A. F., Mrljak, V. and Eckersall, P. D. 2018. 'Proteomics in Veterinary Medicine and Animal Science: Neglected Scientific Opportunities with Immediate Impact'. *Proteomics* 18 (14): 1800047. <https://doi.org/10.1002/pmic.201800047>.
- Binarová, P. and Tuszynski, J. 2019. 'Tubulin: Structure, Functions and Roles in Disease'. *Cells* 8 (10): 1294. <https://doi.org/10.3390/cells8101294>.
- Blackwood, C. B., Marsh, T., Kim, S. H. and Paul, E. A. 2003. 'Terminal Restriction Fragment Length Polymorphism Data Analysis for Quantitative Comparison of Microbial Communities'. *Applied and Environmental Microbiology* 69 (2): 926–32. <https://doi.org/10.1128/AEM.69.2.926-932.2003>.
- Blake, D. P. 2014. 'Securing Poultry Production from the Ever-Present Eimeria Challenge'. *Cell Press* 30 (1): 9. <https://doi.org/10.1016/j.pt.2013.10.003>
- Bozzi, A. T., and Nolan, E. M. 2020. 'Avian MRP126 Restricts Microbial Growth through Ca(II)-Dependent Zn(II) Sequestration'. *Biochemistry* 59 (6): 802–17. <https://doi.org/10.1021/acs.biochem.9b01012>.
- Braganhol, E., Tamajusuku, A. S. K., Bernardi, A., Wink, M. R. and Battastini, A. M. O. 2007. 'Ecto-5'-Nucleotidase/CD73 Inhibition by Quercetin in the Human U138MG Glioma Cell Line'. *Biochimica et Biophysica Acta (BBA) - General Subjects* 1770 (9): 1352–59. <https://doi.org/10.1016/j.bbagen.2007.06.003>.
- Brisbin, J. T., Gong, J., Orouji, S., Esufali, J., Mallick, A. I., Parvizi, P., Shewen, P. E. and Sharif, S. 2011. 'Oral Treatment of Chickens with Lactobacilli Influences Elicitation of Immune Responses'. *Clinical and Vaccine Immunology* 18 (9): 1447–55. <https://doi.org/10.1128/CVI.05100-11>.
- Bukin, Y. S., Galachyants, Y. P., Morozov, I. V., Bukin, S. V., Zakharenko, A. S. and Zemskaya, T. I. 2019. 'The Effect of 16S rRNA Region Choice on Bacterial Community Metabarcoding Results'. *Scientific Data* 6 (1): 190007. <https://doi.org/10.1038/sdata.2019.7>.
- Bunnori, N. M., Hassan, M. S. A., Saidin, S., Hamdan, N., and Zin, N. H. 2018. 'The near Consumer Insight on Liver Proteomics of Malaysian Broiler in Comparison with Indigenous Chicken'. *International Journal of Advances in Science Engineering and Technology*, 6: 2321 –8991.
- Cao, G., Zeng, X., Liu, J., Yan, F., Xiang, Z., Wang, Y., Tao, F. and Yang, C. 2020. 'Change of Serum Metabolome and Cecal Microflora in Broiler Chickens Supplemented with Grape Seed Extracts'. *Frontiers in Immunology* 11 (December): 610934. <https://doi.org/10.3389/fimmu.2020.610934>.
- Cao, Y., Fanning, S., Proos, S., Jordan, K. and Srikumar, S. 2017. 'A Review on the Applications of Next Generation Sequencing Technologies as Applied to Food-Related Microbiome Studies'. *Frontiers in Microbiology* 8 (September): 1829. <https://doi.org/10.3389/fmicb.2017.01829>.
- Caporaso, J. G., Bittinger, K., Bushman, F. D., DeSantis, T., Andersen, Z. G. L. and Knight, R. 2010. 'PyNAST: A Flexible Tool for Aligning Sequences to a Template Alignment'. *Bioinformatics* 26 (2): 266–67. <https://doi.org/10.1093/bioinformatics/btp636>.
- Caporaso, J. G., Kuczynski, J., Stombaugh, J., Bittinger, K., Bushman, F. D., Costello, E. K., Fierer, N. 2010. 'QIIME Allows Analysis of High-Throughput Community

- Sequencing Data'. *Nature Methods* 7 (5): 335–36. <https://doi.org/10.1038/nmeth.f.303>.
- Carneiro, G., Radcenco A. L., Evaristo, J. and Monnerat, M. 2019. 'Novel Strategies for Clinical Investigation and Biomarker Discovery: A Guide to Applied Metabolomics'. *Hormone Molecular Biology and Clinical Investigation* 38 (3). <https://doi.org/10.1515/hmbci-2018-0045>.
- Catozzi, C., Ceciliani, F., Lecchi, C., Talenti, A., Vecchio, D., De Carlo, E., Grassi, C., Sánchez, A., Francino, O. and Cuscó A. 2020. 'Short Communication: Milk Microbiota Profiling on Water Buffalo with Full-Length 16S rRNA Using Nanopore Sequencing'. *Journal of Dairy Science* 103 (3): 2693–2700. <https://doi.org/10.3168/jds.2019-17359>.
- Cech, N. B., and Enke, C. G. 2001. 'Practical Implications of Some Recent Studies in Electrospray Ionization Fundamentals'. *Mass Spectrometry Reviews* 20 (6): 362–87. <https://doi.org/10.1002/mas.10008>.
- Ceciliani, F., Eckersall, D., Burchmore, R. and Lecchi, C. 2014. 'Proteomics in Veterinary Medicine: Applications and Trends in Disease Pathogenesis and Diagnostics'. *Veterinary Pathology* 51 (2): 351–62. <https://doi.org/10.1177/0300985813502819>.
- Ceciliani, F., Giordano, A. and Spagnolo, V. 2002. 'The Systemic Reaction During Inflammation: The Acute-Phase Proteins'. *Protein and Peptide Letters* 9 (3): 211–23. <https://doi.org/10.2174/0929866023408779>.
- Cermelli, S., Zerega, B., Carlevaro, M., Gentili, C., Thorp, B., Farquharson, C., Cancedda, R. and Cancedda, F. D. 2000. 'Extracellular Fatty Acid Binding Protein (Ex-FABP) Modulation by Inflammatory Agents: physiological Acute Phase Response in Endochondral Bone Formation', *European Journal of Cell Biology* 79, 155 ± 164.
- Chandramouli, K., and Qian, P. Y. 2009. 'Proteomics: Challenges, Techniques and Possibilities to Overcome Biological Sample Complexity'. *Human Genomics and Proteomics*. <https://doi.org/10.4061/2009/239204>.
- Chaves, H. A. J. 2014. 'Poultry and Avian Diseases'. In *Encyclopedia of Agriculture and Food Systems*, 504–20. Elsevier. <https://doi.org/10.1016/B978-0-444-52512-3.00183-2>.
- Chen, C. H., Sheu, M. T., Chen, T. F., Wang, Y. C., Hou, W. C., Liu, D. Z., Chung, T. C. and Liang, Y. C. 2006. 'Suppression of Endotoxin-Induced Proinflammatory Responses by Citrus Pectin through Blocking LPS Signaling Pathways'. *Biochemical Pharmacology* 72 (8): 1001–9. <https://doi.org/10.1016/j.bcp.2006.07.001>.
- Choi, J.H., Kim, G.B. and Cha, C.J. 2014. 'Spatial Heterogeneity and Stability of Bacterial Community in the Gastrointestinal Tracts of Broiler Chickens'. *Poultry Science* 93 (8): 1942–50. <https://doi.org/10.3382/ps.2014-03974>.
- Chong, J. and Xia, J. 2020. 'Using MetaboAnalyst 4.0 for Metabolomics Data Analysis, Interpretation, and Integration with Other Omics Data'. *Computational Methods and Data Analysis for Metabolomics*, 2104:337–60. https://doi.org/10.1007/978-1-0716-0239-3_17.
- Chowdhury, V. S., Han, G., Eltahan, H. M., Haraguchi, S., Gilbert, E. R., Cline, M. A., Cockrem, J. F., Bungo, T. and Furuse, M. 2021. 'Potential Role of Amino Acids in the Adaptation of Chicks and Market-Age Broilers to Heat Stress'. *Frontiers in Veterinary Science* 7: 610541. <https://doi.org/10.3389/fvets.2020.610541>.
- Clarridge, J. E. 2004. 'Impact of 16S rRNA Gene Sequence Analysis for Identification of Bacteria on Clinical Microbiology and Infectious Diseases'. *Clinical Microbiology Reviews* 17 (4): 840–62. <https://doi.org/10.1128/CMR.17.4.840-862.2004>.
- Clements, R. L. 1964. 'Organic Acids in Citrus Fruits. I. Varietal Differences'. *Journal of Food Science* 29 (3): 276–80. <https://doi.org/10.1111/j.1365-2621.1964.tb01731.x>.

- Correnti, C., Clifton, M. C., Abergel, R. J., Allred, B., Hoette, M. T., Ranieri, M., Cancedda, R., Raymond, K. N., Descalzi, F. and Strong, R. K. 2011. 'Galline Ex-FABP Is an Antibacterial Siderocalin and a Lysophosphatidic Acid Sensor Functioning through Dual Ligand Specificities'. *Cell press* 19 (12): 1796–1806. <https://doi.org/10.1016/j.str.2011.09.019>.
- Corthésy, B., Gaskins, H. R. and Mercenier, A. 2007. 'Cross-Talk between Probiotic Bacteria and the Host Immune System'. *The Journal of Nutrition* 137 (3): 781S–790S. <https://doi.org/10.1093/jn/137.3.781S>.
- Costa, M., and Weese J. S. 2019. 'Methods and Basic Concepts for Microbiota Assessment'. *The Veterinary Journal* 249: 10–15. <https://doi.org/10.1016/j.tvjl.2019.05.005>.
- Cray, C., Zaias, J. and Altman, N. H. 2009. 'Acute Phase Response in Animals: A Review'. *Comparative Medicine* 59 (6): 10.
- Crhanova, M., Hradecka, H., Faldynova, M., Matulova, M., Havlickova, H., Sisak, F. and Rychlik, I. 2011. 'Immune Response of Chicken Gut to Natural Colonization by Gut Microflora and to Salmonella Enterica Serovar Enteritidis Infection'. *Infection and immunity*. 79(9): 2755–2763. <https://doi.org/10.1128/IAI.01375-10>
- Csernus, B., Biró, S., Babinszky, L., Komlósi, I., Jávora, A., Stündl, L., Remenyik, J. 2020. 'Effect of Carotenoids, Oligosaccharides and Anthocyanins on Growth Performance, Immunological Parameters and Intestinal Morphology in Broiler Chickens Challenged with Escherichia Coli Lipopolysaccharide'. *Animals* 10 (2): 347. <https://doi.org/10.3390/ani10020347>.
- Cuccato, M., Rubiola, S., Giannuzzi, D., Grego, E., Pregel, P., Divari, S. and Cannizzo, F. T. 2021. '16S RRNA Sequencing Analysis of the Gut Microbiota in Broiler Chickens Prophylactically Administered with Antimicrobial Agents'. *Antibiotics* 10 (2): 146. <https://doi.org/10.3390/antibiotics10020146>.
- Cui, Y., Tian, Z.M., Deng, D., Liu, Z. C., Wang, G., Chen, W. D. and Ma, X. Y. 2021. 'Effects of Dietary Citrus Extract on Growth Performance, Carcass Characteristics and Meat Quality of Pigs'. *Journal of Animal Physiology and Animal Nutrition*, August, jpn.13623. <https://doi.org/10.1111/jpn.13623>.
- Cui, Y., Tian, Z., Wang, G., Ma, X. and Chen, W. 2020. 'Citrus Extract Improves the Absorption and Utilization of Nitrogen and Gut Health of Piglets'. *Animals* 10 (1): 112. <https://doi.org/10.3390/ani10010112>.
- Cuscó, A., Viñes, J., D'Andreano, S., Riva, F., Casellas, J., Sánchez, A. and Francino O. 2017. 'Using MinION™ to Characterize Dog Skin Microbiota through Full-Length 16S RRNA Gene Sequencing Approach'. Preprint. *Microbiology*. <https://doi.org/10.1101/167015>.
- Danzeisen, J. L., Kim, H. B., Isaacson, R. E., Tu, Z. J. and Johnson, T. J. 2011. 'Modulations of the Chicken Cecal Microbiome and Metagenome in Response to Anticoccidial and Growth Promoter Treatment'. *PLoS ONE* 6 (11): e27949. <https://doi.org/10.1371/journal.pone.0027949>.
- Dauksiene, A., Ruzauskas, M., Gruzauskas, R., Zavistanaviciute, P., Starkute, V., Klupsaite, D., Klementaviciute J. and Elena Bartkiene. 2021. 'A Comparison Study of the Caecum Microbial Profiles, Productivity and Production Quality of Broiler Chickens Fed Supplements Based on Medium Chain Fatty and Organic Acids'. *Animals* 11 (3): 610. <https://doi.org/10.3390/ani11030610>.
- Debnath, M., Godavarthi B. K. S. Prasad, and Bisen, P.S. 2005. 'Omics Technology'. *Molecular Diagnostics: Promises and Possibilities* 1–520. <https://doi.org/10.1007/978-90-481-3261-4>.
- Deng, X., Cong, Y., Yin, R., Yang, G., Yu, S., Liu, X., Wang, C. and Ding, Z. 2014. 'Proteomic Analysis of Chicken Peripheral Blood Mononuclear Cells after Infection

- by Newcastle Disease Virus'. *Journal of Veterinary Science* 15 (4): 511. <https://doi.org/10.4142/jvs.2014.15.4.511>.
- Di Marco, E., Sessarego, N., Zerega, B., Cancedda, R. and Cancedda F. D. 2003. 'Inhibition of Cell Proliferation and Induction of Apoptosis By Ex-FABP Gene Targeting'. *Journal of Cellular Physiology* 196 (3): 464–73. <https://doi.org/10.1002/jcp.10310>.
- Díaz C., María, J., Redondo, E. A., Viso, N. D. P., Redondo, L. M., Farber, M. D. and Miyakawa, M. E. F. 2018. 'Tannins and Bacitracin Differentially Modulate Gut Microbiota of Broiler Chickens'. *BioMed Research International* 2018: 1–11. <https://doi.org/10.1155/2018/1879168>.
- Dibner, J.J. and Richards J.D. 2005. 'Antibiotic Growth Promoters in Agriculture: History and Mode of Action'. *Poultry Science* 84 (4): 634–43. <https://doi.org/10.1093/ps/84.4.634>.
- Diz, A. P., Truebano, M. and Skibinski, D. O. F. 2009. 'The Consequences of Sample Pooling in Proteomics: An Empirical Study'. *Electrophoresis* 30 (17): 2967–75. <https://doi.org/10.1002/elps.200900210>.
- Doherty, M. K., McLean, L., Hayter, J. R., Pratt, J. M., Robertson, D. H. L., El-Shafei, A., Gaskell, S. J., & Beynon, R. J. 2004. 'The proteome of chicken skeletal muscle: changes in soluble protein expression during growth in a layer strain'. *Proteomics*. 4, 2082–93.
- Dolka, B., Chrobak-Chmiel, D., Czopowicz, M. and Szeleszczuk, P. 2017. 'Characterization of Pathogenic Enterococcus Cecorum from Different Poultry Groups: Broiler Chickens, Layers, Turkeys, and Waterfowl'. Edited by Anderson de Souza Sant'Ana. *Plos One* 12 (9): e0185199. <https://doi.org/10.1371/journal.pone.0185199>.
- Ducatelle, R., Goossens, E., De Meyer, F., Eeckhaut, V., Antonissen, G., Haesebrouck, F. and Van Immerseel, F. 2018. 'Biomarkers for Monitoring Intestinal Health in Poultry: Present Status and Future Perspectives'. *Veterinary Research* 49 (1): 1–9. <https://doi.org/10.1186/s13567-018-0538-6>.
- Ebrahimi, A., Santini, A., Alise, M., Pourhossein, Z., Miraalami, N. and Seidavi, A. 2015. 'Effect of Dried Citrus Sinensis Peel on Gastrointestinal Microbiota and Immune System Traits of Broiler Chickens'. *Italian Journal of Animal Science* 14 (4): 4194. <https://doi.org/10.4081/ijas.2015.4194>.
- Eckersall, P. D. 1995. 'Acute-Phase Proteins as Markers of Inflammatory Lesions'. *Comparative Haematology International* 5:93-97. [10.1007/bf00638925](https://doi.org/10.1007/bf00638925)
- Eckersall, P. D. and Bell, R. 2010. 'Acute phase proteins: Biomarkers of infection and inflammation in veterinary medicine. *Veterinary Journal*'. 185, 23–7.
- Edgar, R. C. 2010. 'Search and Clustering Orders of Magnitude Faster than BLAST'. *Bioinformatics* 26 (19): 2460–61. <https://doi.org/10.1093/bioinformatics/btq461>.
- Eltazi, S. M A. 2014. 'Effect of Using Anise Seeds Powder as Natural Feed Additive'. *International Journal of Pharmaceutical Research and Allied Sciences* 3(2):1-8.
- Emmerson DA. Commercial approaches to genetic selection for growth and feed conversion in domestic poultry. *Poult Sci.* 1997 Aug;76(8):1121-5. doi: 10.1093/ps/76.8.1121. PMID: 9251138.
- Erhan, M. K., and Bölükbaşı, S. 2017. 'Citrus Peel Oils Supplementation in Broiler Diet: Effects on Performance, Jejunum Microflora and Jejunum Morphology'. *Revista Brasileira de Ciência Avícola* 19: 15–22. <https://doi.org/10.1590/1806-9061-2016-0274>.
- Erhan, M. K., Bölükbaşı, S. and Ürüsan, H. 2012. 'Biological Activities of Pennyroyal (*Mentha Pulegium* L.) in Broilers'. *Livestock Science* 146 (2–3): 189–92. <https://doi.org/10.1016/j.livsci.2012.01.014>.
- Frag, M., Tawfike, A., Donia, M., Ehrlich, A. and Wessjohann, L. 2019. 'Influence of Pickling Process on Allium Cepa and Citrus Limon Metabolome as Determined via

- Mass Spectrometry-Based Metabolomics'. *Molecules* 24 (5): 928. <https://doi.org/10.3390/molecules24050928>.
- Fatoba, A. J. and Adeleke, M. 2018. 'Diagnosis and Control of Chicken Coccidiosis: A Recent Update'. *Journal of Parasitic Diseases* 42 (4): 483–93. <https://doi.org/10.1007/s12639-018-1048-1>.
- Ferguson, D. M., and Gerrard, D. E. 2014. 'Regulation of Post-Mortem Glycolysis in Ruminant Muscle'. *Animal Production Science* 54 (4): 464. <https://doi.org/10.1071/AN13088>.
- Ferreira, T., and Rasband, W. 2012. 'ImageJ User Guide', 198.
- Feye, K.M., Baxter, M.F.A., Tellez-Isaias, G., Kogut, M.H. and Ricke S.C. 2020. 'Influential Factors on the Composition of the Conventionally Raised Broiler Gastrointestinal Microbiomes'. *Poultry Science* 99 (2): 653–59. <https://doi.org/10.1016/j.psj.2019.12.013>.
- Fonseca, L. D., Eler, J. P., Pereira, M. A., Rosa, A. F., Alexandre, P. A., Moncau, C. T., Salvato, F. 2019. 'Liver Proteomics Unravel the Metabolic Pathways Related to Feed Efficiency in Beef Cattle'. *Scientific Reports* 9 (1): 5364. <https://doi.org/10.1038/s41598-019-41813-x>.
- Fotakis, C., Lantzouraki, D. Z., Goliomytis, M., Simitzis, P., Charismiadou, M., Deligeorgis, S. G. and Zoumpoulakis, P. 2017. 'NMR Metabolomics Investigates the Influence of Flavonoid- Enriched Rations on Chicken Plasma'. *Journal of AOAC International* 100:2.
- French, C. E., Sales, M. A., Rochell, S. J., Rodriguez, A. and Erf, G. F. 2020. 'Local and Systemic Inflammatory Responses to Lipopolysaccharide in Broilers: New Insights Using a Two-Window Approach'. *Poultry Science* 99 (12): 6593–6605. <https://doi.org/10.1016/j.psj.2020.09.078>.
- Gan, L., Fan, H., Mahmood, T. and Guo, Y. 2020. 'Dietary Supplementation with Vitamin C Ameliorates the Adverse Effects of Salmonella Enteritidis-Challenge in Broilers by Shaping Intestinal Microbiota'. *Poultry Science* 99 (7): 3663–74. <https://doi.org/10.1016/j.psj.2020.03.062>.
- Gao, Y., Islam, M. S., Tian, J., Lui, V. W. Y. and Xiao, D. 2014. 'Inactivation of ATP Citrate Lyase by Cucurbitacin B: A Bioactive Compound from Cucumber, Inhibits Prostate Cancer Growth'. *Cancer Letters* 349 (1): 15–25. <https://doi.org/10.1016/j.canlet.2014.03.015>.
- Garca-Descalzo, L., Garca-Lpez, E., Alczar, A., Baquero, F. and Ci, C. 2012. 'Gel Electrophoresis of Proteins'. In *Gel Electrophoresis - Principles and Basics*. InTech. <https://doi.org/10.5772/37514>.
- Garcia, K. O., Berchieri-Junior, A., Santana, A. M., Freitas-Neto, O. C. and Fagliari, J. J. 2009. 'Experimental Infection of Commercial Layers Using a Salmonella Enterica Serovar Gallinarum Strain: Leukogram and Serum Acute-Phase Protein Concentrations'. *Revista Brasileira de Ciência Avícola* 11 (4): 263–70. <https://doi.org/10.1590/S1516-635X2009000400008>.
- Gentili, C., Tutolo, G., Zerega, B., Di Marco, E., Cancedda, R. and Cancedda, F. D. 2005. 'Acute Phase Lipocalin Ex-FABP Is Involved in Heart Development and Cell Survival'. *Journal of Cellular Physiology* 202 (3): 683–89. <https://doi.org/10.1002/jcp.20165>.
- Ghareeb, K., Awad, W.A., Böhm, J. and Zebeli, Q. 2016. 'Impact of Luminal and Systemic Endotoxin Exposure on Gut Function, Immune Response and Performance of Chickens'. *World's Poultry Science Journal* 72 (2): 367–80. <https://doi.org/10.1017/S0043933916000180>.
- Gilbert, E. R., Williams, P. M., Ray, W. K., Li, H., Emmerson, D. A., Wong, E. A. and Webb, K. E. 2010. 'Proteomic Evaluation of Chicken Brush-Border Membrane

- during the Early Posthatch Period'. *Journal of Proteome Research* 9 (9): 4628–39. <https://doi.org/10.1021/pr1003533>.
- Gil-Cardoso, K., Ginés, I., Pinent, M., Ardévol, A., Blay, M. and Terra, X. 2016. 'Effects of Flavonoids on Intestinal Inflammation, Barrier Integrity and Changes in Gut Microbiota during Diet-Induced Obesity'. *Nutrition Research Reviews* 29 (2): 234–48. <https://doi.org/10.1017/S0954422416000159>.
- Gilda JE, Ghosh R, Cheah JX, West TM, Bodine SC, Gomes AV. Western Blotting Inaccuracies with Unverified Antibodies: Need for a Western Blotting Minimal Reporting Standard (WBMRS). *PLoS One*. 2015 Aug 19;10(8):e0135392. doi: 10.1371/journal.pone.0135392. PMID: 26287535; PMCID: PMC4545415.
- Glendinning, L., Watson, K. A. and Watson, M. 2019. 'Development of the Duodenal, Ileal, Jejunal and Caecal Microbiota in Chickens'. *Animal Microbiome* 1 (1): 17. <https://doi.org/10.1186/s42523-019-0017-z>.
- Gloaguen, Y., Morton, F., Daly, R., Gurden, R., Rogers, R., Wandy, J., Wilson, D., Barrett, M. and Burgess, K. 2017. 'PiMP My Metabolome: An Integrated, Web-Based Tool for LC-MS Metabolomics Data'. Edited by Jonathan Wren. *Bioinformatics* 33 (24): 4007–9. <https://doi.org/10.1093/bioinformatics/btx499>.
- Goldansaz, S. A., Guo, A. C., Sajed, T., Steele, M. A., Plastow, G. S. and Wishart, D. S. 2017. 'Livestock Metabolomics and the Livestock Metabolome: A Systematic Review'. Edited by Marinus F.W. te Pas. *Plos One* 12 (5): e0177675. <https://doi.org/10.1371/journal.pone.0177675>.
- Goliomytis, M., Simitzis, P., Papalexi, A., Veneti, N., Hager-Theodorides, A. L., Charismiadou, M. A. and Deligeorgis, S. G. 2019. 'Influence of Citrus Flavonoids on Laying Hen Performance, Inflammatory Immune Response, Egg Quality and Yolk Oxidative Stability'. *British Poultry Science* 60 (3): 272–78. <https://doi.org/10.1080/00071668.2019.1587150>.
- Gong, J., Forster, R. J., Yu, H., Chambers, R. J., Wheatcroft, R., Sabour, P. M. and Chen, S. 2002. 'Molecular Analysis of Bacterial Populations in the Ileum of Broiler Chickens and Comparison with Bacteria in the Cecum'. *FEMS Microbiology Ecology* 41 (3): 171–79. <https://doi.org/10.1111/j.1574-6941.2002.tb00978.x>.
- Gong, J., Si, W., Forster, R. J., Huang, R., Yu, H., Yin, Y., Yang, C. and Han, Y. 2007. '16S RRNA Gene-Based Analysis of Mucosa-Associated Bacterial Community and Phylogeny in the Chicken Gastrointestinal Tracts: From Crops to Ceca: Mucosa-Associated Bacteria of the Chicken GI Tract'. *FEMS Microbiology Ecology* 59 (1): 147–57. <https://doi.org/10.1111/j.1574-6941.2006.00193.x>.
- Gordon, B. S., Kelleher, A. R. and Kimball, S. R. 2013. 'Regulation of Muscle Protein Synthesis and the Effects of Catabolic States'. *The International Journal of Biochemistry and Cell Biology* 45 (10): 2147–57. <https://doi.org/10.1016/j.biocel.2013.05.039>.
- Gowda, G., Nagana, A. and Djukovic, D. 2014. 'Overview of Mass Spectrometry-Based Metabolomics: Opportunities and Challenges'. *Methods in Molecular Biology* 1198:3–12. https://doi.org/10.1007/978-1-4939-1258-2_1.
- Grant, A., Gay, C. G. and Lillehoj, H. S. 2018. 'Bacillus Spp. as Direct-Fed Microbial Antibiotic Alternatives to Enhance Growth, Immunity, and Gut Health in Poultry'. *Avian Pathology* 47 (4): 339–51. <https://doi.org/10.1080/03079457.2018.1464117>.
- Graves, P. R. and Haystead T. A. J. 2002. 'Molecular Biologist's Guide to Proteomics' 66 (1): 39–63. <https://doi.org/10.1128/MMBR.66.1.39>.
- Griening, G., Liang, T. J., Beuving, G., Goldfarb, V., Metcalfe, S. A. and Muller-Eberhard, U. 1986. 'Hemopexin Is a Developmentally Regulated, Acute-Phase Plasma Protein in the Chicken.' *Journal of Biological Chemistry* 261 (33): 15719–24. [https://doi.org/10.1016/S0021-9258\(18\)66777-8](https://doi.org/10.1016/S0021-9258(18)66777-8).

- Griffin HD and Goddard C. Rapidly growing broiler (meat-type) chickens: their origin and use for comparative studies of the regulation of growth. *Int J Biochem.* 1994 Jan;26(1):19-28. doi: 10.1016/0020-711x(94)90190-2. PMID: 8138043.
- Grilli, E, Messina, M. R., Catelli, E., Morlacchini, M. and Piva, A. 2006. 'Pediocin Improves Growth Performance of Broilers Challenged with *Clostridium perfringens*'. *Poultry Science* 88:2152–2158. <https://doi.org/10.3382/ps.2009-00160>.
- Gruys, E., Toussaint, M.J.M., Upragarin, N., Van, E. A. M., Adewuyi, A.A., Candiani, D., Nguyen, T.K.A. and Sabeckiene, J. 2005. 'Acute Phase Reactants, Challenge in the near Future of Animal Production and Veterinary Medicine'. *Journal of Zhejiang 6B* (10): 941–47. <https://doi.org/10.1631/jzus.2005.B0941>.
- Gunning, P., O'neill, G. and Hardeman, E. 2008. 'Tropomyosin-Based Regulation of the Actin Cytoskeleton in Time and Space'. *Physiological Reviews* 88 (1): 1–35. <https://doi.org/10.1152/physrev.00001.2007>.
- Guo, P., Zhang, K., Ma, X. and He, P. 2020. 'Clostridium Species as Probiotics: Potentials and Challenges'. *Journal of Animal Science and Biotechnology* 11 (1): 24. <https://doi.org/10.1186/s40104-019-0402-1>.
- Hafeez, A., Männer, K., Schieder, C. and Zentek, J. 2016. 'Effect of Supplementation of Phytogenic Feed Additives (Powdered vs. Encapsulated) on Performance and Nutrient Digestibility in Broiler Chickens'. *Poultry Science* 95 (3): 622–29. <https://doi.org/10.3382/ps/pev368>.
- Hager-Theodorides, A. L., Goliomytis, M., Delis, S. and Deligeorgis S. 2014. 'Effects of Dietary Supplementation with Quercetin on Broiler Immunological Characteristics'. *Animal Feed Science and Technology* 198: 224–30. <https://doi.org/10.1016/j.anifeedsci.2014.09.021>.
- Haghighi, H. R., Gong, J., Gyles, C. L., Hayes, M. A., Zhou, H., Sanei, B., J Chambers, J. R. and Sharif, R. 2006. 'Probiotics Stimulate Production of Natural Antibodies in Chickens'. *Clinical and Vaccine Immunology* 13 (9): 975–80. <https://doi.org/10.1128/CVI.00161-06>.
- Hasin, Y., Seldin, M. and Lusic, A. 2017. 'Multi-Omics Approaches to Disease'. *Genome Biology* 18 (1): 1–15. <https://doi.org/10.1186/s13059-017-1215-1>.
- Haskó, G. 2004. 'Adenosine: An Endogenous Regulator of Innate Immunity'. *Trends in Immunology* 25 (1): 33–39. <https://doi.org/10.1016/j.it.2003.11.003>.
- Hassan, M. S. A., Saidin, M. S., Ashima, N., Hamid, S. A. and Bunnori, N. M. 2018. 'Proteomics of broiler's liver'. *International Journal of Advances in Science Engineering and Technology* 6(2): 2321–8991.
- Haudek, S. B., Natmessnig, B. E., First, W., Bahrami, S., Schlag, G. and Redl, H. 2003. 'Lipopolysaccharide Dose Response in Baboons': *Shock* 20 (5): 431–36. <https://doi.org/10.1097/01.shk.0000090843.66556.74>.
- He, J., Zhang, P., Shen, L., Niu, L., Tan, Y., Chen, L. and Zhao, Y. 2020. 'Short-Chain Fatty Acids and Their Association with Signalling Pathways in Inflammation, Glucose and Lipid Metabolism'. *International Journal of Molecular Sciences* 21 (17): 6356. <https://doi.org/10.3390/ijms21176356>.
- He, J., Ning, C., Wang, Y., Ma, T., Huang, H., Ge, Y., Liu, J. and Jiang Y. 2015. 'Natural Plant Flavonoid Apigenin Directly Disrupts Hsp90/Cdc37 Complex and Inhibits Pancreatic Cancer Cell Growth and Migration'. *Journal of Functional Foods* 18: 10–21. <https://doi.org/10.1016/j.jff.2015.06.052>.
- Heckathorn, S. A., Downs, C. A. and Coleman, J. S. 1999. 'Small Heat Shock Proteins Protect Electron Transport in Chloroplasts and Mitochondria During Stress'. *American Zoologist* 39 (6): 865–76. <https://doi.org/10.1093/icb/39.6.865>.

- Henriksen, R., Rettenbacher, S. and Groothuis, T. G. G. 2011. 'Prenatal Stress in Birds: Pathways, Effects, Function and Perspectives'. *Neuroscience and Biobehavioral Reviews* 35 (7): 1484–1501. <https://doi.org/10.1016/j.neubiorev.2011.04.010>.
- Hills, R., Pontefract, B., Mishcon, H., Black, C., Sutton, S. and Theberge C. 2019. 'Gut Microbiome: Profound Implications for Diet and Disease'. *Nutrients* 11 (7): 1613. <https://doi.org/10.3390/nu11071613>.
- Hoeven-Hangoor, E., Van der Vossen, J.M.B.M., Schuren, F. H. J., Verstegen, M. W. A., de Oliveira, J. E., Montijn, R. C. and Hendriks, W. H. 2013. 'Ileal Microbiota Composition of Broilers Fed Various Commercial Diet Compositions'. *Poultry Science* 92 (10): 2713–23. <https://doi.org/10.3382/ps.2013-03017>.
- Holecek, M. 2012. 'Muscle Wasting in Animal Models of Severe Illness: Muscle Wasting in Models of Severe Illness'. *International Journal of Experimental Pathology* 93 (3): 157–71. <https://doi.org/10.1111/j.1365-2613.2012.00812.x>.
- Horvatić, A., Guillemin, G., Kaab, H., McKeegan D., O'Reilly, E., Bain, M., Kuleš, J., and Eckersall, P.D. 2019. 'Quantitative Proteomics Using Tandem Mass Tags in Relation to the Acute Phase Protein Response in Chicken Challenged with Escherichia Coli Lipopolysaccharide Endotoxin'. *Journal of Proteomics*, 192: 64-77 <https://doi.org/10.1016/j.jprot.2018.08.009>.
- Hosokawa, N., Hirayoshi, K., Nakai, A., Hosokawa, Y., Marui, N., Yoshida, M. and Sakai T. 1990. 'Flavonoids Inhibit the Expression of Heat Shock Proteins.' *Cell Structure and Function* 15 (6): 393–401. <https://doi.org/10.1247/csf.15.393>.
- Hoter, A., El-Sabban, M. and Naim, H. 2018. 'The Hsp90 Family: Structure, Regulation, Function, and Implications in Health and Disease'. *International Journal of Molecular Sciences* 19 (9): 2560. <https://doi.org/10.3390/ijms19092560>.
- Hrubec, T. C., Whichard, J. M., Larsen, C. T. and Pierson, F. W. 2002. 'Plasma Versus Serum: Specific Differences in Biochemical Analyte Values'. *Journal of Avian Medicine and Surgery* 16 (2): 101–5. [https://doi.org/10.1647/1082-6742\(2002\)016\[0101:PVSSDI\]2.0.CO;2](https://doi.org/10.1647/1082-6742(2002)016[0101:PVSSDI]2.0.CO;2).
- Hu, H., Dai, S., Li, J., Wen, A. and Bai, X. 2020. 'Glutamine Improves Heat Stress–Induced Oxidative Damage in the Broiler Thigh Muscle by Activating the Nuclear Factor Erythroid 2–Related 2/Kelch-like ECH-Associated Protein 1 Signaling Pathway'. *Poultry Science* 99 (3): 1454–61. <https://doi.org/10.1016/j.psj.2019.11.001>.
- Huang, P., Zhang, Y., Xiao, K., Jiang, F., Wang, H., Tang, D., Liu, D. 2018a. 'The Chicken Gut Metagenome and the Modulatory Effects of Plant-Derived Benzylisoquinoline Alkaloids'. *Microbiome* 6 (1): 211. <https://doi.org/10.1186/s40168-018-0590-5>.
- Huang, S., Li, R., Zhang, Z., Li, L., Gu, X., Fan, W., Lucas, W. J. 2009. 'The Genome of the Cucumber, *Cucumis Sativus* L.' *Nature Genetics* 41 (12): 1275–81. <https://doi.org/10.1038/ng.475>.
- Huang, T., Gao, B., Chen, W., Xiang, R. and Yuan, M. 2018b. 'Temporal Effects of High Fishmeal Diet on Gut Microbiota and Immune Response in *Clostridium Perfringens*-Challenged Chickens' *Microbiome* 9: 1–10. <https://doi.org/10.3389/fmicb.2018.02754>.
- Huang, Y., Lv H., Song, Y., Sun, C., Zhang, Z. and Chen, S. 2021. 'Community Composition of Cecal Microbiota in Commercial Yellow Broilers with High and Low Feed Efficiencies'. *Poultry Science* 100 (4): 100996. <https://doi.org/10.1016/j.psj.2021.01.019>.
- Iqbal, Y., Cottrell, J. J., Suleria, H. A. R. and Dunshea, F. R. 2020. 'Gut Microbiota-Polyphenol Interactions in Chicken: A Review'. *Animals* 10 (8): 1391. <https://doi.org/10.3390/ani10081391>.
- Ishisono, K., Yabe, T. and Kitaguchi, K. 2017. 'Citrus Pectin Attenuates Endotoxin Shock via Suppression of Toll-like Receptor Signaling in Peyer's Patch Myeloid Cells'.

- Journal of Nutritional Biochemistry 50: 38–45.
<https://doi.org/10.1016/j.jnutbio.2017.07.016>.
- Itoh, H., Tamura, K., Izumi, M., Motoi, Y., Kidoguchi, K. and Funayama, Y. 1993. 'The Influence of Age and Health Status on the Serum Alpha₂-Acid Glycoprotein Level of Conventional and Specific Pathogen-Free Pigs' *Canadian Journal of Veterinary Research* 57: 74-78
- Jacob, J. 2013. 'Avian Digestive System', Cooperative extension service, ASC 203.
- Jacobsen, S. 2007. 'Review of Equine Acute-Phase Proteins'. *Infectious diseases*, 6:53.
- Jain, S., Gautam, V. and Naseem, S. 2011. 'Acute-Phase Proteins: As Diagnostic Tool'. *Journal of Pharmacy and Bioallied Sciences* 3 (1): 118. <https://doi.org/10.4103/0975-7406.76489>.
- Jandhyala, S. M. 2015. 'Role of the Normal Gut Microbiota'. *World Journal of Gastroenterology* 21 (29): 8787. <https://doi.org/10.3748/wjg.v21.i29.8787>.
- Jia, A. F., Feng, J. H., Zhang, M. H., Chang, Y., Li, Z. Y., Hu, C. H., Zhen, L., Zhang, S. S. and Peng, Q. Q. 2015. 'Effects of Immunological Challenge Induced by Lipopolysaccharide on Skeletal Muscle Fiber Type Conversion of Piglets¹'. *Journal of Animal Science* 93 (11): 5194–5203. <https://doi.org/10.2527/jas.2015-9391>.
- Jia, W., Slominski, B. A., Bruce, H. L., Blank, G., Crow, G. and Jones, O. 2009. 'Effects of Diet Type and Enzyme Addition on Growth Performance and Gut Health of Broiler Chickens during Subclinical *Clostridium Perfringens* Challenge'. *Poultry Science* 88 (1): 132–40. <https://doi.org/10.3382/ps.2008-00204>.
- Johnson, C. H., Ivanisevic, J. and Siuzdak, G. 2016. 'Metabolomics: Beyond Biomarkers and towards Mechanisms'. *Nature Reviews Molecular Cell Biology* 17 (7): 451–59. <https://doi.org/10.1038/nrm.2016.25>.
- Johnson, J. S., Spakowicz, D. J., Hong, B., Petersen, L. M., Demkowicz, P., Chen, L., Leopold, S. R. 2019. 'Evaluation of 16S rRNA Gene Sequencing for Species and Strain-Level Microbiome Analysis'. *Nature Communications* 10 (1): 5029. <https://doi.org/10.1038/s41467-019-13036-1>.
- Jovel, J., Patterson, J., Wang, W., Hotte, N., O'Keefe, S., Mitchel, T., Perry, T. 2016. 'Characterization of the Gut Microbiome Using 16S or Shotgun Metagenomics'. *Frontiers in Microbiology* 7. <https://doi.org/10.3389/fmicb.2016.00459>.
- Józefiak, D., Rutkowski, A. and Martin S.A. 2004. 'Carbohydrate Fermentation in the Avian Ceca: A Review'. *Animal Feed Science and Technology* 113 (1–4): 1–15. <https://doi.org/10.1016/j.anifeedsci.2003.09.007>.
- Julian, R. J. 2005. 'Production and Growth-Related Disorders and Other Metabolic Diseases of Poultry – A Review'. *The Veterinary Journal* 169 (3): 350–69. <https://doi.org/10.1016/j.tvjl.2004.04.015>.
- Jung, A., Metzner, M. and Ryll, M. 2017. 'Comparison of Pathogenic and Non-Pathogenic *Enterococcus Cecorum* Strains from Different Animal Species'. *BMC Microbiology* 17 (1): 33. <https://doi.org/10.1186/s12866-017-0949-y>.
- Jurburg, S. D., Brouwer, M. S. M., Ceccarelli, D., Goot, J., Jansman, A. J. M., and Bossers, A. 2019. 'Patterns of Community Assembly in the Developing Chicken Microbiome Reveal Rapid Primary Succession'. *Microbiology* 8:(9). <https://doi.org/10.1002/mbo3.821>.
- Kamboh, A.A., Hang, S.-Q., Khan, M. A. and Zhu, W.-Y. 2016. 'In Vivo Immunomodulatory Effects of Plant Flavonoids in Lipopolysaccharide-Challenged Broilers'. *Animal* 10 (10): 1619–25. <https://doi.org/10.1017/S1751731116000562>.
- Karcher, D. M. and Mench, J. A. 2018. 'Overview of Commercial Poultry Production Systems and Their Main Welfare Challenges'. In *Advances in Poultry Welfare*, 3–25. Elsevier. <https://doi.org/10.1016/B978-0-08-100915-4.00001-4>.

- Kemmett, K., N. J., Chaloner, W. G., Humphrey, S., Wigley, P. and Humphrey, T. 2014. 'The Contribution of Systemic Escherichia Coli Infection to the Early Mortalities of Commercial Broiler Chickens'. *Avian Pathology* 43 (1): 37–42. <https://doi.org/10.1080/03079457.2013.866213>.
- Kevyn L. A., Peng, P. H., Peng, R. K. and Klasing, K. C. 2001. 'The Kinetics of Hemopexin and A1-Acid Glycoprotein Levels Induced by Injection of Inflammatory Agents in Chickens', *American Association of Avian Pathologists* 45(2): 289-296.
- Khattak, F., Ronchi, A., Castelli, P. and Sparks N. 2014. 'Effects of Natural Blend of Essential Oil on Growth Performance, Blood Biochemistry, Cecal Morphology, and Carcass Quality of Broiler Chickens'. *Poultry Science* 93 (1): 132–37. <https://doi.org/10.3382/ps.2013-03387>.
- Khovidhunkit, W., Memon, R. A., Feingold, K. R., and Grunfeld, C. 2000. 'Infection and Inflammation-Induced Proatherogenic Changes of Lipoproteins'. *The Journal of Infectious Diseases* 181: S462–72. <https://doi.org/10.1086/315611>.
- Kim, A., Im, M., Gu, M. J. and Ma, J. M. 2016. 'Citrus Unshiu Peel Extract Alleviates Cancer-Induced Weight Loss in Mice Bearing CT-26 Adenocarcinoma'. *Scientific Reports* 6 (1): 24214. <https://doi.org/10.1038/srep24214>.
- Kiu, R., Brown, J., Bedwell, H., Leclaire, C., Caim, S., Pickard, D., Dougan, G., Dixon, R. A. and Hall, L. J. 2019. 'Genomic Analysis on Broiler-Associated Clostridium Perfringens Strains and Exploratory Caecal Microbiome Investigation Reveals Key Factors Linked to Poultry Necrotic Enteritis'. *Animal Microbiome* 1 (1): 12. <https://doi.org/10.1186/s42523-019-0015-1>.
- Klindworth, A., Pruesse, E., Schweer, T., Peplies, J., Quast, C., Horn, M. and Glöckner, F. O. 2013. 'Evaluation of General 16S Ribosomal RNA Gene PCR Primers for Classical and Next-Generation Sequencing-Based Diversity Studies'. *Nucleic Acids Research* 41 (1): 1–1. <https://doi.org/10.1093/nar/gks808>.
- Koppenol, A., Everaert, N., Buyse, J. and Delezie, E. 2015. 'Challenge with Lipopolysaccharides or Freund's Adjuvant? What Is the Best Option to Trigger Acute Phase Protein Production in Broilers?' *Research in Veterinary Science* 99: 96–98. <https://doi.org/10.1016/j.rvsc.2015.01.013>.
- Koupenova, M. and Ravid, K. 2013. 'Adenosine, Adenosine Receptors and Their Role in Glucose Homeostasis and Lipid Metabolism: Adenosine and metabolism'. *Journal of Cellular Physiology* 228 (8): 1703–12. <https://doi.org/10.1002/jcp.24352>.
- Krauze, M., Cendrowska-Pinkosz, M., Matusevičius, P., Stępniewska, A., Jurczak P. and Ognik, K. 2021. 'The Effect of Administration of a Phytobiotic Containing Cinnamon Oil and Citric Acid on the Metabolism, Immunity, and Growth Performance of Broiler Chickens'. *Animals* 11 (2): 399. <https://doi.org/10.3390/ani11020399>.
- Kuczynski, J., Lauber, C. L., Walters, W. A., Parfrey, L. W., Clemente, J. C., Gevers, D. and Knight, R. 2012. 'Experimental and Analytical Tools for Studying the Human Microbiome'. *Nature Reviews Genetics* 13 (1): 47–58. <https://doi.org/10.1038/nrg3129>.
- Kumar, C. and Mann, M. 2009. 'Bioinformatics Analysis of Mass Spectrometry-Based Proteomics Data Sets'. *Frontiers in Veterinary Science* 583 (11): 1703–12. <https://doi.org/10.1016/j.febslet.2009.03.035>.
- Kumar, D., Kumar, S., Singh, J., Rashmi, N., Vashistha, B. D. and Singh, N. 2010. 'Free Radical Scavenging and Analgesic Activities of Cucumis Sativus L. Fruit Extract'. *Journal of Young Pharmacists* 2 (4): 365–68. <https://doi.org/10.4103/0975-1483.71627>.
- Kumar, S., Chen, C., Indugu, N., Werlang, G. O., Singh, M., Kim, W. K. and Thippareddi, H. 2018. 'Effect of Antibiotic Withdrawal in Feed on Chicken Gut Microbial

- Dynamics, Immunity, Growth Performance and Prevalence of Foodborne Pathogens'. *Plos One* 13 (2): e0192450. <https://doi.org/10.1371/journal.pone.0192450>.
- Kumar, S., Shang, Y. and Kim, W. K. 2019. 'Insight Into Dynamics of Gut Microbial Community of Broilers Fed With Fructooligosaccharides Supplemented Low Calcium and Phosphorus Diets'. *Frontiers in Veterinary Science* 6:95. <https://doi.org/10.3389/fvets.2019.00095>.
- Lamichhane, S., Sundekilde, U. K., Blædel, T., Dalsgaard, T. K., Larsen, L. H., Dragsted, L. O., Astrup, A. and Bertram, H. C. 2017. 'Optimizing Sampling Strategies for NMR-Based Metabolomics of Human Feces: Pooled vs. Unpooled Analyses'. *Analytical Methods* 9 (30): 4476–80. <https://doi.org/10.1039/C7AY01465A>.
- Landers, T. F., Cohen, B., Wittum, T. E. and Larson, E. L. 2012. 'A Review of Antibiotic Use in Food Animals: Perspective, Policy, and Potential'. *Public Health Reports* 127 (1): 4–22. <https://doi.org/10.1177/003335491212700103>.
- Landman, W. J. M., Gruys, E. and Gielkens, A. L. J. 1998. 'Avian Amyloidosis'. *Avian Pathology* 27 (5): 437–49. <https://doi.org/10.1080/03079459808419367>.
- Lara, L. and Rostagno, M. 2013. 'Impact of Heat Stress on Poultry Production'. *Animals* 3 (2): 356–69. <https://doi.org/10.3390/ani3020356>.
- Lee, K. W., Lillehoj, H. S., Jang, S. I., Lee, S. H., Bautista, D. A. and Siragusa G. R. 2013. 'Effect of Bacillus Subtilis Based Direct-Fed Microbials on Immune Status in Broiler Chickens Raised on Fresh or Used Litter'. *Asian-Australasian Journal of Animal Sciences* 26 (11): 1592–97. <https://doi.org/10.5713/ajas.2013.13178>.
- Lee, Y., Jung, j. and Kim, H. 2011. 'Hesperidin Partially Restores Impaired Immune and Nutritional Function in Irradiated Mice'. *Journal of Medicinal Food* 14 (5): 475–82. <https://doi.org/10.1089/jmf.2010.1269>.
- Leeson, S., Caston, L. and Summers, J. D. 1995. 'Broiler Response to Diet Energy', *Poultry Science* 75:529-535.
- Lei, J. Y. and Bao, E. 2009. 'Expression of Heat Shock Protein 90 (Hsp90) and Transcription of Its Corresponding MRNA in Broilers Exposed to High Temperature'. *British Poultry Science* 50 (4): 504–11. <https://doi.org/10.1080/00071660903110851>.
- Leiva, E., Hall, M.B. and Van Horn, H.H. 2000. 'Performance of Dairy Cattle Fed Citrus Pulp or Corn Products as Sources of Neutral Detergent-Soluble Carbohydrates'. *Journal of Dairy Science* 83 (12): 2866–75. [https://doi.org/10.3168/jds.S0022-0302\(00\)75187-3](https://doi.org/10.3168/jds.S0022-0302(00)75187-3).
- Lenhardt, L., and Možeš Š. 2003. 'Morphological and Functional Changes of the Small Intestine in Growth-Stunted Broilers'. *Acta Veterinaria Brno* 72 (3): 353–58. <https://doi.org/10.2754/avb200372030353>.
- Li, S., Qi, Y., Chen, L., Qu, D., Li, Z., Gao, K., Chen, J., and Sun, Y. 2019. 'Effects of Panax Ginseng Polysaccharides on the Gut Microbiota in Mice with Antibiotic-Associated Diarrhea'. *International Journal of Biological Macromolecules* 124:931–37. <https://doi.org/10.1016/j.ijbiomac.2018.11.271>.
- Lieboldt, M.A., Frahm, J., Halle, I., Görs, S., Schrader, L., Weigend, S., Preisinger, R., Metges, C.C., Breves, G. and Dänicke, S. 2016. 'Metabolic and Clinical Response to Escherichia Coli Lipopolysaccharide in Layer Pullets of Different Genetic Backgrounds Supplied with Graded Dietary L-Arginine'. *Poultry Science* 95 (3): 595–611. <https://doi.org/10.3382/ps/pev359>.
- Lilley, K. S., and Friedman, D. B. (2004). 'All about DIGE: Quantification Technology for Differential-Display 2D-Gel Proteomics'. *Expert Review of Proteomics* 1 (4): 401–9. <https://doi.org/10.1586/14789450.1.4.401>.
- Liu, L., Shen, J., Zhao, C., Wang, X., Yao, J., Gong, Y., and Yang, X.. 2015. 'Dietary Astragalus Polysaccharide Alleviated Immunological Stress in Broilers Exposed to

- Lipopolysaccharide'. *International Journal of Biological Macromolecules* 72 (January): 624–32. <https://doi.org/10.1016/j.ijbiomac.2014.08.057>.
- Liu, X., Mao, B., Gu, J., Wu, J., Cui, S., Wang, G., Zhao, J., Zhang, H. and Chen, W. 2021. 'Blautia —a New Functional Genus with Potential Probiotic Properties?' *Gut Microbes* 13 (1): 1875796. <https://doi.org/10.1080/19490976.2021.1875796>.
- Lowe, D. A., Degens, H., Chen, K. D. and Always, S. E. 2000. 'Glyceraldehyde-3-Phosphate Dehydrogenase Varies with Age in Glycolytic Muscles of Rats'. *The Journals of Gerontology Series A: Biological Sciences and Medical Sciences* 55 (3): B160–64. <https://doi.org/10.1093/gerona/55.3.B160>.
- Lowrie, M., Penderis, J., Eckersall, P. D., McLaughlin, M., Mellor, D. and Anderson T. J. 2009. 'The Role of Acute Phase Proteins in Diagnosis and Management of Steroid-Responsive Meningitis Arteritis in Dogs'. *The Veterinary Journal* 182 (1): 125–30. <https://doi.org/10.1016/j.tvjl.2008.05.001>.
- Lu, H., Giordano, F. and Ning, Z. 2016. 'Oxford Nanopore MinION Sequencing and Genome Assembly'. *Genomics, Proteomics and Bioinformatics* 14 (5): 265–79. <https://doi.org/10.1016/j.gpb.2016.05.004>.
- Lu, J., Idris, U., Harmon, U., Hofacre, C., Maurer, J. J. and Lee, M. D. 2003. 'Diversity and Succession of the Intestinal Bacterial Community of the Maturing Broiler Chicken'. *Applied and Environmental Microbiology* 69 (11): 6816–24. <https://doi.org/10.1128/AEM.69.11.6816-6824.2003>.
- Lucke, A., Böhm, J., Zebeli, Q. and Metzler-Zebeli, B. U. 2018. 'Dietary Deoxynivalenol Contamination and Oral Lipopolysaccharide Challenge Alters the Cecal Microbiota of Broiler Chickens'. *Frontiers in Microbiology* 9:804. <https://doi.org/10.3389/fmicb.2018.00804>.
- Luo, J., Zheng, A., Meng, K., Chang, W., Bai, Y., Li, K., Cai, H., Liu, G. and Yao, B. 2013. 'Proteome Changes in the Intestinal Mucosa of Broiler (*Gallus Gallus*) Activated by Probiotic *Enterococcus Faecium*'. *Journal of Proteomics* 91: 226–41. <https://doi.org/10.1016/j.jprot.2013.07.017>.
- Luthman, J., Jacobsson, S. O. and Frank, A. 1991. 'Endotoxin-Induced Changes in Plasma Mineral and Vitamin Levels in Calves'. *Acta Veterinaria Scandinavica* 32 (3): 403–4. <https://doi.org/10.1186/BF03546971>.
- Ma, B., Zhang, L., Li, J., Xing, T., Jiang, Y. and Gao, F. 2021. 'Heat Stress Alters Muscle Protein and Amino Acid Metabolism and Accelerates Liver Gluconeogenesis for Energy Supply in Broilers'. *Poultry Science* 100 (1): 215–23. <https://doi.org/10.1016/j.psj.2020.09.090>.
- Mahmood, T. and Guo, Y. 2020. 'Dietary Fiber and Chicken Microbiome Interaction: Where Will It Lead To?' *Animal Nutrition* 6 (1): 1–8. <https://doi.org/10.1016/j.aninu.2019.11.004>.
- Mandey, J. S., Wolayan, F. R., Pontoh, C. J. and Kowel, Y. H. S. 2020. 'Effect of Orally Administrated of Cucumber (*Cucumis Sativus* L.) Seed Juice on the Performance and Carcass Parameters of Broiler Chickens'. *IOP Conference Series: Earth and Environmental Science* 492 (1): 012025. <https://doi.org/10.1088/1755-1315/492/1/012025>.
- Mao, G., Li, S., Orfila, C., Shen, X., Zhou, S., Linhardt, R. J., Ye, X. and Chen, S. 2019. 'Depolymerized RG-I-Enriched Pectin from Citrus Segment Membranes Modulates Gut Microbiota, Increases SCFA Production, and Promotes the Growth of *Bifidobacterium* Spp., *Lactobacillus* Spp. and *Faecalibaculum* Spp.' *Food & Function* 10 (12): 7828–43. <https://doi.org/10.1039/C9FO01534E>.
- Marangoni, F., Corsello, G., Cricelli, C., Ferrara, N., Ghiselli, A., Lucchin, L. and Poli, A. 2015. 'Role of Poultry Meat in a Balanced Diet Aimed at Maintaining Health and

- Wellbeing: An Italian Consensus Document'. *Food and Nutrition Research* 59 (1): 27606. <https://doi.org/10.3402/fnr.v59.27606>.
- Marciano, C., Marinho, M., Mércia A., Ibelli, G., Marchesi, J. A. P., Peixoto, J., Fernandes, L. T., Savoldi, I. R., Carmo, K. B. and Ledur, M. C. 2021. 'Differential Expression of Myogenic and Calcium Signaling-Related Genes in Broilers Affected with White Striping'. *Frontiers in Physiology* 12: 712464. <https://doi.org/10.3389/fphys.2021.712464>.
- Marín, L., Miguélez, E. M., Villar, C. J. and Lombó, F. 2015. 'Bioavailability of Dietary Polyphenols and Gut Microbiota Metabolism: Antimicrobial Properties'. *BioMed Research International*: 1–18. <https://doi.org/10.1155/2015/905215>.
- Martin, M. 2011. 'Cutadapt Removes Adapter Sequences from High-Throughput Sequencing Reads'. *EMB Net Journal* 17.1.
- Martínez-Reyes, I. and Chandel, N. S. 2020. 'Mitochondrial TCA Cycle Metabolites Control Physiology and Disease'. *Nature Communications* 11 (1): 102. <https://doi.org/10.1038/s41467-019-13668-3>.
- Masella, A. P, Bartram, A. K., Truszkowski, J. M., Brown, D. G. and Neufeld, J. D. 2012. 'PANDAseq: PAired-END Assembler for Illumina Sequences', 7.
- Matulova, M., Varmuzova, K., Sisak, F., Havlickova, H., Babak, V., Stejskal, K., Zdrahal, Z. and Rychlik, I. 2013. 'Chicken Innate Immune Response to Oral Infection with Salmonella Enterica Serovar Enteritidis'. *Veterinary Research* 44 (1): 37. <https://doi.org/10.1186/1297-9716-44-37>.
- Mavrommatis, A., Zografaki, M., Marka, S., Myrtsi, E. D., Giamouri, E., Christodoulou, C. and Evergetis E. 2022. 'Effect of a Carotenoid Extract from Citrus Reticulata By-Products on the Immune-Oxidative Status of Broilers'. *Antioxidants* 11 (1): 144. <https://doi.org/10.3390/antiox11010144>.
- May A. H., Hassan, A. M., Hussain, M. M., El-Wahed, Z. H. A. 2007. 'Effect of Chronic Heat Stress on Broiler Chicks Performance and Immune System', Abstract.
- McNally, D. J., Wurms, K. V., Labbé, C., Quideau, S. and Bélanger, R. R. 2003. 'Complex C -Glycosyl Flavonoid Phytoalexins from Cucumis s Ativus'. *Journal of Natural Products* 66 (9): 1280–83. <https://doi.org/10.1021/np030150y>.
- Mehdi, Y., Létourneau-Montminy, M. P., Gaucher, M. L., Chorfi, Y., Suresh, G., Rouissi, T., Brar, S. K., Côté, C., Ramirez, A. A. and Godbout, S. 2018. 'Use of Antibiotics in Broiler Production: Global Impacts and Alternatives'. *Animal Nutrition* 4 (2): 170–78. <https://doi.org/10.1016/j.aninu.2018.03.002>.
- Mennerat, A., Nilsen, F., Ebert, D. and Skorpung, A. 2010. 'Intensive Farming: Evolutionary Implications for Parasites and Pathogens'. *Evolutionary Biology* 37 (2): 59–67. <https://doi.org/10.1007/s11692-010-9089-0>.
- Meseret, S. 2016. 'A Review of Poultry Welfare in Conventional Production System', no. December.
- Miller, W. R, Munita, J. M. and Arias, C. A. 2014. 'Mechanisms of Antibiotic Resistance in Enterococci'. *Expert Review of Anti-Infective Therapy* 12 (10): 1221–36. <https://doi.org/10.1586/14787210.2014.956092>.
- Mitsch, P., Zitterl-Eglseer, K., Köhler, B., Gabler, C., Losa, R. and Zimpernik, I. 2004. 'The Effect of Two Different Blends of Essential Oil Components on the Proliferation of Clostridium Perfringens in the Intestines of Broiler Chickens'. *Poultry Science* 83 (4): 669–75. <https://doi.org/10.1093/ps/83.4.669>.
- Mogensen, T. H. 2009. 'Pathogen Recognition and Inflammatory Signaling in Innate Immune Defenses'. *Clinical Microbiology Reviews* 22 (2): 240–73. <https://doi.org/10.1128/CMR.00046-08>.
- Mohamed, A.S.A. Lozovsky, A.R and Ali A.M.A. 2019. 'Nutritional Strategies to Alleviate Heat Stress Effects through Feed Restrictions and Feed Additives (Vitamins and

- Minerals) in Broilers under Summer Conditions'. *Journal of Animal Behaviour and Biometeorology* 7 (3): 123–31. <https://doi.org/10.31893/2318-1265jabb.v7n3p123-131>.
- Moore P.R., Evenson A. & et al. (1946) Use of sulfasuxidine, streptothricin, and streptomycin in nutritional studies with the chick. *J Biol Chem* 165, 437-41.
- Morales, M. G., Abrigo, J., Meneses, C., Cisternas, F., Simon, F. and Cabello-Verrugio, C. 2015. 'Expression of the Mas Receptor Is Upregulated in Skeletal Muscle Wasting'. *Histochemistry and Cell Biology* 143 (2): 131–41. <https://doi.org/10.1007/s00418-014-1275-1>.
- Mounia, M., Nadir, A. and Omar, B. 2018. 'Effects of Phytogetic Products on Gut Morpho-Histology of Broiler Chickens'. *International Journal of Veterinary Science and Research* 4 (1): 009–011. <https://doi.org/10.17352/ijvsr.000028>.
- Mountzouris, K.C., Tsirtsikos, P., Kalamara, E., Nitsch, S., Schatzmayr G. and Fegeros, K. 2007. 'Evaluation of the Efficacy of a Probiotic Containing Lactobacillus, Bifidobacterium, Enterococcus, and Pediococcus Strains in Promoting Broiler Performance and Modulating Cecal Microflora Composition and Metabolic Activities'. *Poultry Science* 86 (2): 309–17. <https://doi.org/10.1093/ps/86.2.309>.
- Muhammad, T., Ikram, M., Ullah, R., Rehman, S. and Kim, M. 2019. 'Hesperetin, a Citrus Flavonoid, Attenuates LPS-Induced Neuroinflammation, Apoptosis and Memory Impairments by Modulating TLR4/NF-KB Signaling'. *Nutrients* 11 (3): 648. <https://doi.org/10.3390/nu11030648>.
- Mukherjee, P. K., Nema, N. K., Maity N. and Sarkar, B. K. 2013. 'Fitoterapia Phytochemical and Therapeutic Potential of Cucumber'. *Fitoterapia* 84: 227–36. <https://doi.org/10.1016/j.fitote.2012.10.003>.
- Murakami, A. E., Eyng, C. and Torrent, J. 2014. 'Effects of Functional Oils on Coccidiosis and Apparent Metabolizable Energy in Broiler Chickens'. *Asian-Australasian Journal of Animal Sciences* 27 (7): 981–89. <https://doi.org/10.5713/ajas.2013.13449>.
- Murata, H., Shimada, N. and Yoshioka, M. 2004. 'Current Research on Acute Phase Proteins in Veterinary Diagnosis: An Overview'. *The Veterinary Journal* 168 (1): 28–40. [https://doi.org/10.1016/S1090-0233\(03\)00119-9](https://doi.org/10.1016/S1090-0233(03)00119-9).
- Muruganantham, N., Solomon, S. and Senthamilselvi, M. M. 2016. 'Antimicrobial Activity of Cucumis Sativas (Cucumber) Flowers'. *International Journal of Pharmaceutical Sciences Review and Research* 36 (1): 97–100. [https://doi.org/10.13040/IJPSR.0975-8232.7\(4\).1740-45](https://doi.org/10.13040/IJPSR.0975-8232.7(4).1740-45).
- Nakamura, K., Mitarai, Y., Yoshioka, M., Koizumi, N., Shibahara, T. and Nakajima, T. 1998. 'Serum Levels of Interleukin-6, Alpha1-Acid Glycoprotein, and Corticosterone in Two-Week-Old Chickens Inoculated with Escherichia Coli Lipopolysaccharide'. *Poultry Science* 77 (6): 908–11. <https://doi.org/10.1093/ps/77.6.908>.
- Nakao, R., Abe, T., ANijhof, A. M., Yamamoto, S., Jongejan, F., Ikemura, T. and Sugimoto, C. 2013. 'A Novel Approach, Based on BLSOMs (Batch Learning Self-Organizing Maps), to the Microbiome Analysis of Ticks'. *ISME Journal* 7 (5): 1003–15. <https://doi.org/10.1038/ismej.2012.171>.
- Nangia-Makker, P., Hogan, V., Honjo, Y., Baccarini, S., Tait, L., Bresalier, R. and Raz, A. 2002. 'Inhibition of Human Cancer Cell Growth and Metastasis in Nude Mice by Oral Intake of Modified Citrus Pectin'. *JNCI Journal of the National Cancer Institute* 94 (24): 1854–62. <https://doi.org/10.1093/jnci/94.24.1854>.
- Ndayishimiye, J., Lim, D. J. and Chun, B. S. 2018. 'Antioxidant and Antimicrobial Activity of Oils Obtained from a Mixture of Citrus By-Products Using a Modified Supercritical Carbon Dioxide'. *Journal of Industrial and Engineering Chemistry* 57: 339–48. <https://doi.org/10.1016/j.jiec.2017.08.041>.

- Nelson, E. E. and Guyer, E. A. 2012. 'NIH Public Access' 1 (3): 233–45. <https://doi.org/10.1016/j.dcn.2011.01.002>.The.
- Nema, N. K., Maity, N., Sarkar, B. and Mukherjee, P. K. 2011. 'Cucumis Sativus Fruit-Potential Antioxidant, Anti-Hyaluronidase, and Anti-Elastase Agent'. *Archives of Dermatological Research* 303 (4): 247–52. <https://doi.org/10.1007/s00403-010-1103-y>.
- Nunnally, M. H., Rybicki, S. B. and Stull, J. T. 1985. 'Characterization of Chicken Skeletal Muscle Myosin Light Chain Kinase. Evidence for Muscle-Specific Isozymes.' *Journal of Biological Chemistry* 260 (2): 1020–26. [https://doi.org/10.1016/S0021-9258\(20\)71202-0](https://doi.org/10.1016/S0021-9258(20)71202-0).
- Oakley, B. B. and Kogut, M. K. 2016. 'Spatial and Temporal Changes in the Broiler Chicken Cecal and Fecal Microbiomes and Correlations of Bacterial Taxa with Cytokine Gene Expression'. *Frontiers in Veterinary Science* 3. <https://doi.org/10.3389/fvets.2016.00011>.
- Ong, S. H., Kukkillaya, V. U., Wilm, A., Lay, C., Ho, E. X. P., Low, L., Hibberd, M. L. and Nagarajan, N. 2013. 'Species Identification and Profiling of Complex Microbial Communities Using Shotgun Illumina Sequencing of 16S rRNA Amplicon Sequences'. Edited by John Parkinson. *PLoS ONE* 8 (4): e60811. <https://doi.org/10.1371/journal.pone.0060811>.
- Ontiveros, M., Rinaldi, D., Marder, M., Espelt, M.V., Mangialavori, I., Vigil, M., Rossi, J. P. and Ferreira-Gomes M. 2019. 'Natural Flavonoids Inhibit the Plasma Membrane Ca²⁺-ATPase'. *Biochemical Pharmacology* 166: 1–11. <https://doi.org/10.1016/j.bcp.2019.05.004>.
- O'Reilly, E.L and Eckersall, P. D. 2014. 'Acute Phase Proteins: A Review of Their Function, Behaviour and Measurement in Chickens'. *World's Poultry Science Journal* 70 (1): 27–43. <https://doi.org/10.1017/S0043933914000038>.
- O'Reilly, E. L., Burchmore, R. J., Sparks, N. H. and Eckersall, P.D. 2016. 'The Effect of Microbial Challenge on the Intestinal Proteome of Broiler Chickens'. *Proteome Science* 15 (1): 10. <https://doi.org/10.1186/s12953-017-0118-0>.
- O'Reilly, E. L. 2016. 'Acute Phase Proteins and Biomarkers for Health in Chickens'. Ph D. University of Glasgow.
- Orellana, R. A., Suryawan, A., Wilson, F. A., Gazzaneo, M. C., Fiorotto, M. L., Nguyen, H. V. and Davis, T. A. 2012. 'Development Aggravates the Severity of Skeletal Muscle Catabolism Induced by Endotoxemia in Neonatal Pigs'. *American Journal of Physiology-Regulatory, Integrative and Comparative Physiology* 302 (6): R682–90. <https://doi.org/10.1152/ajpregu.00259.2011>.
- Packialakshmi, B., Liyanage, R., Lay, J. O., Makkar, S. K. and Rath, N. C. 2016. 'Proteomic Changes in Chicken Plasma Induced by Salmonella Typhimurium Lipopolysaccharides'. *Proteomics Insights* 7: PRI.S31609. <https://doi.org/10.4137/PRI.S31609>.
- Pan, D., and Yu, Z. 2014. 'Intestinal Microbiome of Poultry and Its Interaction with Host and Diet'. *Gut Microbes* 5 (1): 12.
- Panche, A. N., Diwan, A. D. and Chandra, S. R. 2016. 'Flavonoids: An Overview'. *Journal of Nutritional Science* 5: e47. <https://doi.org/10.1017/jns.2016.41>.
- Pantsulaia, I., Iobadze, M., Pantsulaia, N. and Chikovani, T. 2014. 'The Effect of Citrus Peel Extracts on Cytokines Levels and T Regulatory Cells in Acute Liver Injury'. *BioMed Research International* 2014: 1–7. <https://doi.org/10.1155/2014/127879>.
- Park, H. M., Lee, J. H., Yaoyao, J., Jun, H. J. and Lee, S. J. 2011. 'Limonene, a Natural Cyclic Terpene, Is an Agonistic Ligand for Adenosine A_{2A} Receptors'. *Biochemical and Biophysical Research Communications* 404 (1): 345–48. <https://doi.org/10.1016/j.bbrc.2010.11.121>.

- Picard, B., Berri, C., Lefaucheur, L., Molette, C., Sayd, T. and Terlouw, C. 2010. 'Skeletal Muscle Proteomics in Livestock Production'. *Briefings in Functional Genomics* 9 (3): 259–78. <https://doi.org/10.1093/bfgp/elq005>.
- Pinu, F. R., Goldansaz, S. A. and Jaïne, J. 2019. 'Translational Metabolomics: Current Challenges and Future Opportunities'. *Metabolites* 9 (6): 108. <https://doi.org/10.3390/metabo9060108>.
- Pirgozliev, V., Stephen C., Mansbridge, P. R. and Bravo D. 2018, 'Plant Extracts, Energy, and Immune Modulation in Broilers', *Phytochemicals - Source of Antioxidants and Role in Disease Prevention*, IntechOpen, London. 10.5772/intechopen.77220.
- Porsch-Özcürümez, M., Kischel, N., Priebe, H., Splettstösser, W., Finke, E. and Grunow, R. 2004. 'Comparison of Enzyme-Linked Immunosorbent Assay, Western Blotting, Microagglutination, Indirect Immunofluorescence Assay, and Flow Cytometry for Serological Diagnosis of Tularemia'. *Clinical and Vaccine Immunology* 11 (6): 1008–15. <https://doi.org/10.1128/CDLI.11.6.1008-1015.2004>.
- Pourabedin, M., Guan, L. and Zhao, X. 2015. 'Xylo-Oligosaccharides and Virginiamycin Differentially Modulate Gut Microbial Composition in Chickens'. *Microbiome* 3 (1): 15. <https://doi.org/10.1186/s40168-015-0079-4>.
- Pourhossein, Z., Qotbi, A. A. A., Seidavi, A., Laudadio, V., Centoducati, G. and Tufarelli, V. 2015. 'Effect of Different Levels of Dietary Sweet Orange (*Citrus Sinensis*) Peel Extract on Humoral Immune System Responses in Broiler Chickens: Dietary Sweet Orange Peel Extract and Broiler Immunity'. *Animal Science Journal* 86 (1): 105–10. <https://doi.org/10.1111/asj.12250>.
- Powers, S. K., Lynch, G. S., Murphy, K. T., Reid, M. B. and Zijdewind, I. 2016. 'Disease-Induced Skeletal Muscle Atrophy and Fatigue'. *Medicine and Science in Sports and Exercise* 48 (11): 2307–19. <https://doi.org/10.1249/MSS.0000000000000975>.
- Prihambodo, T. R., Sholikin, M. M., Jayanegara, N. O. A., Batubara, Desiant, I., Utomo, B. and Nahrowi, N. 2021. 'Effects of Dietary Flavonoids on Performance, Blood Constituents, Carcass Composition and Small Intestinal Morphology of Broilers: A Meta-Analysis'. *Animal Bioscience* 34 (3): 434–42. <https://doi.org/10.5713/ajas.20.0379>.
- Rafiq, S., Kaul, R., Sofi, S. A., Bashir, N., Nazir, F. and Nayik, G. A. 2018. 'Citrus Peel as a Source of Functional Ingredient: A Review'. *Journal of the Saudi Society of Agricultural Sciences* 17 (4): 351–58. <https://doi.org/10.1016/j.jssas.2016.07.006>.
- Ramautar, R., Somsen, G. W. and de Jong, G. J. 2019. 'CE-MS for Metabolomics: Developments and Applications in the Period 2016-2018'. *Electrophoresis* 40 (1): 165–79. <https://doi.org/10.1002/elps.201800323>.
- Ribbenstedt, A., Ziarrusta, H. and Benskin, J. P. 2018. 'Development, Characterization and Comparisons of Targeted and Non-Targeted Metabolomics Methods'. Edited by Francisco J. Schopfer. *Plos One* 13 (11): e0207082. <https://doi.org/10.1371/journal.pone.0207082>.
- Richards-Rios, P., Fothergill, J., Bernardeau, M. and Wigley, P. 2019. 'Development of the Caecal Microbiota in Three Broiler Breeds'. *Frontiers in Veterinary Science* 6: 201. <https://doi.org/10.3389/fvets.2019.00201>.
- Richards-Rios, P., Fothergill, J., Bernardeau, M. and Wigley, P. 2020. 'Development of the Ileal Microbiota in Three Broiler Breeds'. *Frontiers in Veterinary Science* 7:17. <https://doi.org/10.3389/fvets.2020.00017>.
- Ricke, C. S. 2018. 'Impact of Prebiotics on Poultry Production and Food Safety'. *Yale Journal of Biology and Medicine* 91 (2): 151–59.
- Ridley, B. L., O'Neill, M. A. and Mohnen, D. 2001. 'Pectins: Structure, Biosynthesis, and Oligogalacturonide-Related Signaling'. *Phytochemistry* 57 (6): 929–67. [https://doi.org/10.1016/S0031-9422\(01\)00113-3](https://doi.org/10.1016/S0031-9422(01)00113-3).

- Rinschen, M. M., Ivanisevic, J., Giera, M. and Siuzdak, G. 2019. 'Identification of Bioactive Metabolites Using Activity Metabolomics'. *Nature Reviews Molecular Cell Biology* 20 (6): 353–67. <https://doi.org/10.1038/s41580-019-0108-4>.
- Rinttilä, T. and Apajalahti, J. 2013. 'Intestinal Microbiota and Metabolites—Implications for Broiler Chicken Health and Performance'. *Journal of Applied Poultry Research* 22 (3): 647–58. <https://doi.org/10.3382/japr.2013-00742>.
- Roberts, L. D., Souza, A. L., Gerszten, R. E. and Clish, C. B. 2012. 'Targeted Metabolomics'. *Current Protocols in Molecular Biology* 98 (1). <https://doi.org/10.1002/0471142727.mb3002s98>.
- Rojas-Villaraga, A., Castellanos-de la Hoz, J., Perez-Fernandez, O., Amaya-Amaya, J., Franco, J. and Anaya, J. 2013. 'Autoimmunity: From Bench to Bedside', 321–41. <https://doi.org/10.1007/s00265-002-0553-4>.
- Rosenblatt, S. 1983. 'Exchange of Amino Acids by Muscle and Liver in Sepsis: Comparative Studies In Vivo and In Vitro'. *Archives of Surgery* 118 (2): 167. <https://doi.org/10.1001/archsurg.1983.01390020023004>.
- Rosselli, R., Romoli, O., Vitulo, N., Vezzi, A., Campanaro, S., Pascale, F., Schiavon, R. 2016. 'Direct 16S rRNA-Seq from Bacterial Communities: A PCR-Independent Approach to Simultaneously Assess Microbial Diversity and Functional Activity Potential of Each Taxon'. *Scientific Reports* 6 (1): 32165. <https://doi.org/10.1038/srep32165>.
- Rougière, N. and Carré, B. 2010. 'Comparison of Gastrointestinal Transit Times between Chickens from D+ and D– Genetic Lines Selected for Divergent Digestion Efficiency'. *Animal* 4 (11): 1861–72. <https://doi.org/10.1017/S1751731110001266>.
- Rowland, I., Gibson, G., Heinken, A., Scott, K., Swann, J., Thiele, I. and Tuohy, K. 2018. 'Gut Microbiota Functions: Metabolism of Nutrients and Other Food Components'. *European Journal of Nutrition* 57 (1): 1–24. <https://doi.org/10.1007/s00394-017-1445-8>.
- Rubić, I., Burchmore, R., Weidt, S., Regnault, C., Kuleš, J., Barić, R., Rafaj, Mašek, T. 2022. 'Multi Platforms Strategies and Metabolomics Approaches for the Investigation of Comprehensive Metabolite Profile in Dogs with Babesia Canis Infection'. *International Journal of Molecular Sciences* 23 (3): 1575. <https://doi.org/10.3390/ijms23031575>.
- Ruiz, V., Ruiz, D., Gernat, A. G., Grimes, J. L., Murillo, J. G., Wineland, M. J., Anderson, K. E. and Maguire, R. O. 2008. 'The Effect of Quicklime (CaO) on Litter Condition and Broiler Performance.' *Poultry Science* 87 (5): 823–27. <https://doi.org/10.3382/ps.2007-00101>.
- Rychlik, I., Elsheimer-Matulova, M. and Kyrova, K. 2014. 'Gene Expression in the Chicken Caecum in Response to Infections with Non-Typhoid Salmonella'. *Veterinary Research* 45 (1): 119. <https://doi.org/10.1186/s13567-014-0119-2>.
- Saeed, M., Yatao, X., Tiantian, Z., Qian, R. and Chao, S. 2019. '16S Ribosomal RNA Sequencing Reveals a Modulation of Intestinal Microbiome and Immune Response by Dietary L-Theanine Supplementation in Broiler Chickens'. *Poultry Science* 98 (2): 842–54. <https://doi.org/10.3382/ps/pey394>.
- Sahasrabudhe, N. M., Beukema, M., Tian, T., Troost, B., Scholte, J., Bruininx, E., Bruggeman, G. 2018. 'Dietary Fiber Pectin Directly Blocks Toll-Like Receptor 2–1 and Prevents Doxorubicin-Induced Ileitis'. *Frontiers in Immunology* 9: 383. <https://doi.org/10.3389/fimmu.2018.00383>.
- Salini, V., Saggini, A., Maccauro, G., Caraffa, A., Shaik-Dasthagirisahab, Y. B. and Conti, P. 2011. 'Inflammatory Markers: Serum Amyloid A, Fibrinogen and C-Reactive Protein — A Revisited Study'. *European Journal of Inflammation* 9 (2): 95–102. <https://doi.org/10.1177/1721727X1100900202>.

- Salipante, S. J., Kawashima, T., Rosenthal, C., Hoogestraat, D. R., Cummings, Dhruva, L. A., Sengupta, J., Harkins, T. T., Cookson, B. T. and Hoffman, N. G. 2014. 'Performance Comparison of Illumina and Ion Torrent Next-Generation Sequencing Platforms for 16S rRNA-Based Bacterial Community Profiling'. Edited by F. E. Löffler. *Applied and Environmental Microbiology* 80 (24): 7583–91. <https://doi.org/10.1128/AEM.02206-14>.
- Samli, H. E., Senkoylu, N., Koc, F., Kanter, M. and Agha, A. 2007. 'Effects of *Enterococcus Faecium* and Dried Whey on Broiler Performance, Gut Histomorphology and Intestinal Microbiota'. *Archives of Animal Nutrition* 61 (1): 42–49. <https://doi.org/10.1080/17450390601106655>.
- Sandbo, N., Taurin, S., Yau, D., Kregel, S., Mitchell, R. and Dulin, N. 2007. 'Downregulation of Smooth Muscle α -Actin Expression by Bacterial Lipopolysaccharide'. *Cardiovascular Research* 74 (2): 262–69. <https://doi.org/10.1016/j.cardiores.2007.01.011>.
- Sassi, N. B., Averos, X. and Estevez, I. 2016. 'Technology and Poultry Welfare', 1–21. <https://doi.org/10.3390/ani6100062>.
- Savoia, D. 2012. 'Plant-Derived Antimicrobial Compounds: Alternatives to Antibiotics'. *Future Microbiology* 7 (8): 979–90. <https://doi.org/10.2217/fmb.12.68>.
- Scanes, C. G. 2016. 'Biology of Stress in Poultry with Emphasis on Glucocorticoids and the Heterophil to Lymphocyte Ratio'. *Poultry Science* 95 (9): 2208–15. <https://doi.org/10.3382/ps/pew137>.
- Schrimpe-Rutledge, A. C., Codreanu, S. G., Sherrod, S. D. and McLean, J. A. 2016. 'Untargeted Metabolomics Strategies—Challenges and Emerging Directions'. *Journal of the American Society for Mass Spectrometry* 27 (12): 1897–1905. <https://doi.org/10.1007/s13361-016-1469-y>.
- Sergeant, M. J., Constantinidou, C., Cogan, T. A., Bedford, M. R., Penn, C. W. and Pallen, M. J. 2014. 'Extensive Microbial and Functional Diversity within the Chicken Cecal Microbiome'. Edited by John Parkinson. *PLoS One* 9 (3): e91941. <https://doi.org/10.1371/journal.pone.0091941>.
- Shang, Y., Kumar, S., Oakley, B. and Kim, W. K. 2018. 'Chicken Gut Microbiota: Importance and Detection Technology'. *Frontiers in Veterinary Science* 5: 254. <https://doi.org/10.3389/fvets.2018.00254>.
- Siddiqui, F. A., Parkkola, H., Vukic, V., Oetken-Lindholm, C., Jaiswal, A., Kiriazis, A., Pavic, K., Aittokallio, T., Salminen, T. A. and Abankwa, D. 2021. 'Novel Small Molecule Hsp90/Cdc37 Interface Inhibitors Indirectly Target K-Ras-Signaling'. *Cancers* 13 (4): 927. <https://doi.org/10.3390/cancers13040927>.
- Siegel, P. B. 2014. 'Evolution of the Modern Broiler and Feed Efficiency'. *Annual Review of Animal Biosciences* 2 (1): 375–85. <https://doi.org/10.1146/annurev-animal-022513-114132>.
- Simitzis, P. E., Charismiadou, M. A., Goliomytis, M., Charalambous, A., Ntetska, I., Giamouri, E. and Deligeorgis, S. G. 2019. 'Antioxidant Status, Meat Oxidative Stability and Quality Characteristics of Lambs Fed with Hesperidin, Naringin or α -tocopheryl Acetate Supplemented Diets'. *Journal of the Science of Food and Agriculture* 99 (1): 343–49. <https://doi.org/10.1002/jsfa.9193>.
- Simon, A., Gulyás, G., Mészár, Z. Bhide, M., Oláh, J., Bai, P., Csösz, E. 2019. 'Proteomics Alterations in Chicken Jejunum Caused by 24 h Fasting'. *PeerJ* 7 (March): e6588. <https://doi.org/10.7717/peerj.6588>.
- Siuzdak, G. 2004. 'An Introduction to Mass Spectrometry Ionization: An Excerpt from The Expanding Role of Mass Spectrometry in Biotechnology'. *Journal of the Association for Laboratory Automation* 9 (2): 50–63. <https://doi.org/10.1016/j.jala.2004.01.004>.

- Slawinska, A., Hsieh, J. C., Schmidt, C. J. and Lamont, S. J. 2016. 'Heat Stress and Lipopolysaccharide Stimulation of Chicken Macrophage-Like Cell Line Activates Expression of Distinct Sets of Genes'. *Plos One* 11 (10): e0164575. <https://doi.org/10.1371/journal.pone.0164575>.
- Smeriglio, A., Cornara, L., Denaro, M., Barreca, D., Burlando, B., Xiao, J. and Trombetta, D. 2019. 'Antioxidant and Cytoprotective Activities of an Ancient Mediterranean Citrus (*Citrus Lumia Risso*) Albedo Extract: Microscopic Observations and Polyphenol Characterization'. *Food Chemistry* 279: 347–55. <https://doi.org/10.1016/j.foodchem.2018.11.138>.
- Song, D.J. and King, A. J. 2015. 'Effects of Heat Stress on Broiler Meat Quality'. *World's Poultry Science Journal* 71 (4): 701–9. <https://doi.org/10.1017/S0043933915002421>.
- Sood, A., Kaur, P. and Gupta, R. 2012. 'Phytochemical screening and antimicrobial assay of various seeds extract of cucurbitaceae family'. *International Journal of applied Biology and Pharmaceutical Technology* 3(3): 0976-4550.
- Soto-Herederó, G., Gómez de las Heras, M. M., Gabandé-Rodríguez, E., Oller, J. and Mittelbrunn, M. 2020. 'Glycolysis – a Key Player in the Inflammatory Response'. *The FEBS Journal* 287 (16): 3350–69. <https://doi.org/10.1111/febs.15327>.
- Souillard, R., Laurentie, J., Kempf, I., Le Caër, V., Le Bouquin, S., Serror, P. and Allain, V. 2022. 'Increasing Incidence of Enterococcus-Associated Diseases in Poultry in France over the Past 15 Years'. *Veterinary Microbiology* 269: 109426. <https://doi.org/10.1016/j.vetmic.2022.109426>.
- Stamilla, A., Ruiz-Ruiz, S., Artacho, A., Pons, J., Messina, A., Randazzo, C. L., Caggia, C., Lanza, M. and Moya, A. 2021. 'Analysis of the Microbial Intestinal Tract in Broiler Chickens during the Rearing Period'. *Biology* 10 (9): 942. <https://doi.org/10.3390/biology10090942>.
- Steuer, R.; Morgenthal, K.; Weckwerth, W.; Selbig, J. A gentle guide to the analysis of metabolomic data. *Methods Mol. Biol.* 2007, 358, 105–126.
- Stone, E. M., Rothblum, K. N., Alevy, M. C., Kuo, T. M. and Schwartz, R. J. 1985. 'Complete Sequence of the Chicken Glyceraldehyde-3-Phosphate Dehydrogenase Gene.' *Proceedings of the National Academy of Sciences* 82 (6): 1628–32. <https://doi.org/10.1073/pnas.82.6.1628>.
- Syafwan, S., Kwakkel, R.P. and Verstegen, M.W.A. 2011. 'Heat Stress and Feeding Strategies in Meat-Type Chickens'. *World's Poultry Science Journal* 67 (4): 653–74. <https://doi.org/10.1017/S0043933911000742>.
- Szent-Györgyi, A.G. 1975. 'Calcium Regulation of Muscle Contraction'. *Biophysical Journal* 15 (7): 707–23. [https://doi.org/10.1016/S0006-3495\(75\)85849-8](https://doi.org/10.1016/S0006-3495(75)85849-8).
- Takimoto, T., Sato, K., Akiba, Y. and Takahashi, K. 2008. 'Role of Chicken TL1A on Inflammatory Responses and Partial Characterization of Its Receptor'. *The Journal of Immunology* 180 (12): 8327–32. <https://doi.org/10.4049/jimmunol.180.12.8327>.
- Tang, J., Meng, X., Liu, H., Zhao, J., Zhou, L., Qiu, M., Zhang, X., Yu, Z. and Yang, F. 2010. 'Antimicrobial Activity of Sphingolipids Isolated from the Stems of Cucumber (*Cucumis Sativus* L.)'. *Molecules* 15 (12): 9288–97. <https://doi.org/10.3390/molecules15129288>.
- Tang, X., Meng, Q., Gao, J., Zhang, S., Zhang, H. and Zhang, M. 2015. 'Label-Free Quantitative Analysis of Changes in Broiler Liver Proteins under Heat Stress Using SWATH-MS Technology'. *Scientific Reports* 5 (1): 15119. <https://doi.org/10.1038/srep15119>.
- Ten-Doménech, I., Ramos-García, V., Piñeiro-Ramos, J. D., Gormaz, M., Parra-Llorca, A., Vento, M., Kuligowski, J. and Quintás, G. 2020. 'Current Practice in Untargeted Human Milk Metabolomics'. *Metabolites* 10 (2): 43. <https://doi.org/10.3390/metabo10020043>.

- ThermoFisher Scientific. 2016. Overview of ELISA.
- Tesseraud, S., Chagneau, A.M., and Grizard, J. 2000. 'Muscle Protein Turnover during Early Development in Chickens Divergently Selected for Growth Rate'. *Poultry Science* 79 (10): 1465–71. <https://doi.org/10.1093/ps/79.10.1465>.
- Thantrige-Don, N., Parvizi, P., Sarson, A. J., Shack, L. A., Burgess, S. C. and Sharif, S. 2010. 'Proteomic Analysis of Host Responses to Marek's Disease Virus Infection in Splens of Genetically Resistant and Susceptible Chickens'. *Developmental & Comparative Immunology* 34 (7): 699–704. <https://doi.org/10.1016/j.dci.2010.01.016>.
- Theuns, S., Vanmechelen, B., Bernaert, Q., Deboutte, W., Vandenhoe, M., Beller, L., Matthijssens, J., Maes, P. and Nauwynck, H. J. 2018. 'Nanopore Sequencing as a Revolutionary Diagnostic Tool for Porcine Viral Enteric Disease Complexes Identifies Porcine Kobuvirus as an Important Enteric Virus'. *Scientific Reports* 8 (1): 9830. <https://doi.org/10.1038/s41598-018-28180-9>.
- Thornton, P. K. 2010. 'Livestock Production: Recent Trends, Future Prospects', *Philosophical Transactions* 2853–67. <https://doi.org/10.1098/rstb.2010.0134>.
- Tiihonen, K., Kettunen, H., Bento, H. H. L., Saarinen, M., Lahtinen, S., Ouwehand, A. C., Schulze, H. and Rautonen, N. 2010. 'The Effect of Feeding Essential Oils on Broiler Performance and Gut Microbiota'. *British Poultry Science* 51 (3): 381–92. <https://doi.org/10.1080/00071668.2010.496446>.
- Tolnai, E., Fauszt, P., Fidler, G., Pesti-Asboth, G., Szilagyi, E., Stigel, A., Konya, J. 2021. 'Nutraceuticals Induced Changes in the Broiler Gastrointestinal Tract Microbiota'. *MSystems* 6 (2): e01124-20. <https://doi.org/10.1128/mSystems.01124-20>.
- Torok, V. A., Hughes, R. J., Mikkelsen, L. L., Perez-Maldonado, R., Balding, K., MacAlpine, R., Percy, N. J. and Ophel-Keller, K. 2011. 'Identification and Characterization of Potential Performance-Related Gut Microbiotas in Broiler Chickens across Various Feeding Trials'. *Applied and Environmental Microbiology* 77 (17): 5868–78. <https://doi.org/10.1128/AEM.00165-11>.
- Torok, V. A., Ophel-Keller, K., Loo, M. and Hughes, R. J. 2008. 'Application of Methods for Identifying Broiler Chicken Gut Bacterial Species Linked with Increased Energy Metabolism'. *Applied and Environmental Microbiology* 74 (3): 783–91. <https://doi.org/10.1128/AEM.01384-07>.
- Tothova, C., Nagy, O. and Kovac, G. 2014. 'Acute Phase Proteins and Their Use in the Diagnosis of Diseases in Ruminants: A Review'. *Veterinární Medicína* 59 (No. 4): 163–80. <https://doi.org/10.17221/7478-VETMED>.
- Tyler, A. D., Mataseje, L., Urfano, C. J., Schmidt, L., Antonation, K. S., Mulvey, M. R. and Corbett, C. R. 2018. 'Evaluation of Oxford Nanopore's MinION Sequencing Device for Microbial Whole Genome Sequencing Applications'. *Scientific Reports* 8 (1): 10931. <https://doi.org/10.1038/s41598-018-29334-5>.
- Uhlar, C. M. and Whitehead, A. S. 1999. 'Serum Amyloid A, the Major Vertebrate Acute-Phase Reactant'. *European Journal of Biochemistry* 265 (2): 501–23. <https://doi.org/10.1046/j.1432-1327.1999.00657.x>.
- Upragarin, N., Van Asten, J.A.M., Peter C. J. T., Landman, W. J. M and Gruys, E. 2005. 'Serum Amyloid A Production by Chicken Fibroblast-like Synoviocytes'. *Veterinary Immunology and Immunopathology* 106 (1–2): 39–51. <https://doi.org/10.1016/j.vetimm.2005.01.004>.
- Ursell, L. K., Metcalf, J. L., Parfrey, L. W. and Knight, R. 2012. 'Defining the Human Microbiome'. *Nutrition Reviews* 70: S38–44. <https://doi.org/10.1111/j.1753-4887.2012.00493>.
- Van Every, H. A. and Schmidt, C. J. 2021. 'Transcriptomic and Metabolomic Characterization of Post-Hatch Metabolic Reprogramming during Hepatic

- Development in the Chicken'. *BMC Genomics* 22 (1): 380. <https://doi.org/10.1186/s12864-021-07724-w>.
- Vanderhaeghen, W. and Dewulf, J. 2017. 'Antimicrobial Use and Resistance in Animals and Human Beings'. *The Lancet Planetary Health* 34 (Suppl 3): 93–106. [https://doi.org/10.1016/S2542-5196\(17\)30142-0](https://doi.org/10.1016/S2542-5196(17)30142-0).
- Vandooren, J. and Itoh, Y. 2021. 'Alpha-2-Macroglobulin in Inflammation, Immunity and Infections'. *Frontiers in Immunology* 12: 803244. <https://doi.org/10.3389/fimmu.2021.803244>.
- Velkers, F.C., Graaf-Bloois, L., Wagenaar, J.A., Westendorp, S.T., Bergen, M.A.P., Dwars, R.M. and Landman, W.J.M. 2011. 'Enterococcus Durans-Associated Endocarditis in Broilers'. *Veterinary Quarterly* 31 (1): 3–17. <https://doi.org/10.1080/01652176.2011.570107>.
- Verdal, H., Mignon-Grasteau, S., Jeulin, C., Le Bihan-Duval, E., Leconte, M., Mallet S., Martin, C. and Narcy, A. 2010. 'Digestive Tract Measurements and Histological Adaptation in Broiler Lines Divergently Selected for Digestive Efficiency'. *Poultry Science* 89 (9): 1955–61. <https://doi.org/10.3382/ps.2010-813>.
- Vidanarachchi, J. K., Elangovan, A. V., Mikkelsen, L. L., Choct, M. and Iji, P. A. 2010. 'Effect of Some Plant Extracts on Growth Performance, Intestinal Morphology, Microflora Composition and Activity in Broiler Chickens'. *Animal Production Science* 50 (9): 880. <https://doi.org/10.1071/AN10011>.
- Vieco-Saiz, N., Belguesmia, Y., Raspoet, R., Gancel, E. A., Kempf, I. and Drider, D. 2019. 'Benefits and Inputs from Lactic Acid Bacteria and Their Bacteriocins as Alternatives to Antibiotic Growth Promoters During Food-Animal Production'. *Frontiers in Microbiology* 10: 57. <https://doi.org/10.3389/fmicb.2019.00057>.
- Vieira, A. M., Soratto, T. A. T., Cardinal, K. M., Wagner, G., Hauptli, L., Lima, A. L. F., Dahlke, F., Netto, D. M., Moraes, P. O. and Ribeiro, A. M. L. 2020. 'Modulation of the Intestinal Microbiota of Broilers Supplemented with Monensin or Functional Oils in Response to Challenge by Eimeria Spp.' Edited by Michael H. Kogut. *Plos One* 15 (8): e0237118. <https://doi.org/10.1371/journal.pone.0237118>.
- Vouldoukis, I., Lacan, D., Kamate, C., Coste, P., Calenda, A., Mazier, D., Conti, M. and Dugas, B. 2004. 'Antioxidant and Anti-Inflammatory Properties of a Cucumis Melo LC. Extract Rich in Superoxide Dismutase Activity' 94: 67–75. <https://doi.org/10.1016/j.jep.2004.04.023>.
- Waite, D. W. and Taylor, M. W. 2015. 'Exploring the Avian Gut Microbiota: Current Trends and Future Directions'. *Frontiers in Microbiology* 6. <https://doi.org/10.3389/fmicb.2015.00673>.
- Wang, B., Wang, S., Ding, M., Lu, H., Wu, H. and Li, Y. 2022. 'Quercetin Regulates Calcium and Phosphorus Metabolism Through the Wnt Signaling Pathway in Broilers'. *Frontiers in Veterinary Science* 8: 786519. <https://doi.org/10.3389/fvets.2021.786519>.
- Wang, Y., George, S. P., Srinivasan, K., Patnaik, S. and Khurana, S. 2012. 'Actin Reorganization as the Molecular Basis for the Regulation of Apoptosis in Gastrointestinal Epithelial Cells'. *Cell Death and Differentiation* 19 (9): 1514–24. <https://doi.org/10.1038/cdd.2012.28>.
- Wang, Y., Wu, J., Lv, M., Shao, Z., Hungwe, M., Wang, J., Bai, X., Xie, J., Wang, Y. and Geng, W. 2021. 'Metabolism Characteristics of Lactic Acid Bacteria and the Expanding Applications in Food Industry'. *Frontiers in Bioengineering and Biotechnology* 9: 612285. <https://doi.org/10.3389/fbioe.2021.612285>.
- Wang, Y., Guo, Y., Ning, D., Peng, Y., Cai, H., Tan, J., Yang, Y. and Liu, D. 2012. 'Changes of Hepatic Biochemical Parameters and Proteomics in Broilers with Cold-Induced

- Ascites'. *Journal of Animal Science and Biotechnology* 3 (1): 41. <https://doi.org/10.1186/2049-1891-3-41>.
- Wasti, S., Sah, N. and Mishra, B. 2020. 'Impact of Heat Stress on Poultry Health and Performances, and Potential Mitigation Strategies'. *Animals* 10 (8): 1266. <https://doi.org/10.3390/ani10081266>.
- Wegele, H., Müller, L. and Buchner, J. 2004. 'Hsp70 and Hsp90—a Relay Team for Protein Folding'. In *Reviews of Physiology, Biochemistry and Pharmacology*, 151:1–44. *Reviews of Physiology, Biochemistry and Pharmacology*. Berlin, Heidelberg: Springer Berlin Heidelberg. <https://doi.org/10.1007/s10254-003-0021-1>.
- Wei, S., Morrison, M. and Yu, Z. 2013. 'Bacterial Census of Poultry Intestinal Microbiome'. *Poultry Science* 92 (3): 671–83. <https://doi.org/10.3382/ps.2012-02822>.
- Wilkins, M. R., Sanchez, J., Gooley, A. A., Appel, R. D., Humphery-Smith, I., Hochstrasser, D. F. and Williams, K. L. 1996. 'Progress with Proteome Projects: Why All Proteins Expressed by a Genome Should Be Identified and How To Do It'. *Biotechnology and Genetic Engineering Reviews* 13 (1): 19–50. <https://doi.org/10.1080/02648725.1996.10647923>.
- Williams, N. C. and O'Neill, L. A. J. 2018. 'A Role for the Krebs Cycle Intermediate Citrate in Metabolic Reprogramming in Innate Immunity and Inflammation'. *Frontiers in Immunology* 9: 141. <https://doi.org/10.3389/fimmu.2018.00141>.
- Wilson, F.D., Cummings, T. S., Barbosa, T. M., Williams, C. J., Gerard, P. D. and Peebles, E. D. 2018. 'Comparison of Two Methods for Determination of Intestinal Villus to Crypt Ratios and Documentation of Early Age-Associated Ratio Changes in Broiler Chickens'. *Poultry Science* 97 (5): 1757–61. <https://doi.org/10.3382/ps/pex349>.
- Wu, C., Chen, C., Liu, Y., Li, H. and Cheng, B. 2021. 'Proteomic Analysis of Liver Tissue between Fat and Lean Broiler Lines'. *British Poultry Science* 62 (2): 211–18. <https://doi.org/10.1080/00071668.2020.1847253.a>
- Wu, Y., Li, Q., Liu, J., Liu, Y., Xu, Y. Zhang, R., Yu, Y., Wang, Y. and Yang, C. 2021. 'Integrating Serum Metabolome and Gut Microbiome to Evaluate the Benefits of Lauric Acid on Lipopolysaccharide- Challenged Broilers'. *Frontiers in Immunology* 12: 759323. <https://doi.org/10.3389/fimmu.2021.759323.b>
- Xiao, S.-S., Mi, J., Mei, L., Liang, J., Feng, K. X., Wu, Y. B., Liao, X. D. and Wang, Y. 2021. 'Microbial Diversity and Community Variation in the Intestines of Layer Chickens'. *Animals* 11 (3): 840. <https://doi.org/10.3390/ani11030840>.
- Xiao, Y., Xiang, Y., Zhou, W., Chen, J., Li, K. and Yang, H. 2017. 'Microbial Community Mapping in Intestinal Tract of Broiler Chicken'. *Poultry Science* 96 (5): 1387–93. <https://doi.org/10.3382/ps/pew372>.
- Xie, H., Huff, G.R., Huff, W.E., Balog, J.M., Holt, P. and Rath, N.C. 2002. 'Identification of Ovotransferrin as an Acute Phase Protein in Chickens'. *Poultry Science* 81 (1): 112–20. <https://doi.org/10.1093/ps/81.1.112>.
- Xie, H., Rath, N. C., Huff, G.R., Huff, W.E. and Balog, J.M. 2000. 'Effects of Salmonella Typhimurium Lipopolysaccharide on Broiler Chickens'. *Poultry Science* 79 (1): 33–40. <https://doi.org/10.1093/ps/79.1.33>.
- Yadav, S., and Jha, R. 2019. 'Strategies to Modulate the Intestinal Microbiota and Their Effects on Nutrient Utilization, Performance, and Health of Poultry'. *Journal of Animal Science and Biotechnology* 10 (1): 2. <https://doi.org/10.1186/s40104-018-0310-9>.
- Yan, W., Sun, C., Zheng, J., Wen, C., Ji, C., Zhang, D., Chen, Y., Hou, Z. and Yang, N. 2019. 'Efficacy of Fecal Sampling as a Gut Proxy in the Study of Chicken Gut Microbiota'. *Frontiers in Microbiology* 10: 2126. <https://doi.org/10.3389/fmicb.2019.02126>.

- Yang, L., Belobrajdic, B., Feng, A. and Zhang, D. 2020. 'Role of Dietary Nutrients in the Modulation of Gut Microbiota: A Narrative Review'. *Nutrients* 12 (2): 381. <https://doi.org/10.3390/nu12020381>.
- Yanibada, B., Boudra, H., Debrauwer, L., Martin, C., Morgavi, D. P. and Canlet, C. 2018. 'Evaluation of Sample Preparation Methods for NMR-Based Metabolomics of Cow Milk'. *Heliyon* 4 (10): e00856. <https://doi.org/10.1016/j.heliyon.2018.e00856>.
- Yates, J. R. 2011. 'A Century of Mass Spectrometry: From Atoms to Proteomes'. *Nature Methods* 8 (8): 633–37. <https://doi.org/10.1038/nmeth.1659>.
- Yegani, M., and Korver, D. R. 2008. 'Factors Affecting Intestinal Health in Poultry'. *Poultry Science* 87 (10): 2052–63. <https://doi.org/10.3382/ps.2008-00091>.
- Yu, M., Li, Z., Chen, W., Wang, G., Cui, Y. and Ma, X. 2019. 'Dietary Supplementation with Citrus Extract Altered the Intestinal Microbiota and Microbial Metabolite Profiles and Enhanced the Mucosal Immune Homeostasis in Yellow-Feathered Broilers'. *Frontiers in Microbiology* 10 (November): 2662. <https://doi.org/10.3389/fmicb.2019.02662>.
- Yuki, M., Itoh, H. and Takase, K. 2010. 'Serum α -1-Acid Glycoprotein Concentration in Clinically Healthy Puppies and Adult Dogs and in Dogs with Various Diseases'. *Veterinary Clinical Pathology* 39 (1): 65–71. <https://doi.org/10.1111/j.1939-165X.2009.00181.x>.
- Zaefarian, F., Abdollahi, M., Cowieson, A. and Ravindran, V. 2019. 'Avian Liver: The Forgotten Organ'. *Animals* 9 (2): 63. <https://doi.org/10.3390/ani9020063>.
- Zhang, J.F., Bai, K.W., Su, W.P., Wang, A.A., Zhang, L.L., Huang, K.H. and Wang, T. 2018. 'Curcumin Attenuates Heat-Stress-Induced Oxidant Damage by Simultaneous Activation of GSH-Related Antioxidant Enzymes and Nrf2-Mediated Phase II Detoxifying Enzyme Systems in Broiler Chickens'. *Poultry Science* 97 (4): 1209–19. <https://doi.org/10.3382/ps/pex408>.
- Zhao, X. and Kuipers, O. P. 2016. 'Identification and Classification of Known and Putative Antimicrobial Compounds Produced by a Wide Variety of Bacillales Species'. *BMC Genomics* 17 (1): 882. <https://doi.org/10.1186/s12864-016-3224-y>.
- Zheng, A., Luo, J., Meng, K., Li, J., Bryden, W. L., Chang, W., Zhang, S., Wang, L. X. N., Liu, G. and Yao, B. 2016. 'Probiotic (*Enterococcus Faecium*) Induced Responses of the Hepatic Proteome Improves Metabolic Efficiency of Broiler Chickens (*Gallus Gallus*)'. *BMC Genomics* 17 (1): 89. <https://doi.org/10.1186/s12864-016-2371-5>.
- Zhu, N., Wang, J., Yu, L., Zhang, Q., Chen, K. and Liu, B. 2019. 'Modulation of Growth Performance and Intestinal Microbiota in Chickens Fed Plant Extracts or Virginiamycin'. *Frontiers in Microbiology* 10: 1333. <https://doi.org/10.3389/fmicb.2019.01333>.
- Zuidhof, M. J., Schneider, B. L., Carney, V. L., Korver, D. R. and Robinson, F. E. 2014. 'Growth, Efficiency, and Yield of Commercial Broilers from 1957, 1978, and 2005'. *Poultry Science* 93(12):2970-2982. <https://doi.org/10.3382/ps.2014-04291>.

Websites

<https://www.statista.com/statistics/237637/production-of-poultry-meat-worldwide-since-1990/> - Accessed on 12.03.2022

<https://ourworldindata.org/meat-production> - Accessed on 10.05.2022

https://en.aviagen.com/assets/Tech_Center/Ross_Broiler/Ross-BroilerHandbook2018-EN.pdf - Accessed on 10.02.2019

<http://www.lumigen.com/products/elisa/lumigen-sparcl> - Accessed on 19.09.2022